



**Diamapro**<sup>®</sup>  
SYSTEMS

## **OWNER'S MANUAL**

# **DX22-P**

## **CONCRETE FLOOR GRINDER**



## **USER & MAINTENANCE BOOK**

SAVE THESE INSTRUCTIONS FOR FUTURE REFERENCE



# WARRANTY REGISTRATION CARD

Form must be completed and submitted within 30 days from the date of purchase.

## Customer Information

First and Last Name

Company Name

Address

City

State

Zip Code

Phone Number

Email

## Machine Information

Machine Type

Machine Model

Serial #

Purchase Date (dd/mm/yy)

Diamapro® Systems  
3343 Peachtree Road NE  
Suite 145 #24  
Atlanta, GA 30326

## INTRODUCTION

Thank you for purchasing a DIAMAPRO® SYSTEMS product. This manual provides information and procedures to safely operate and maintain the DiamaPro® DX22-P. For your own safety and protection from injury, carefully read, understand, and observe the safety instructions described in this manual. Keep this manual or a copy of it with the machine. If you lose this manual or need an additional copy, please contact DiamaPro® Systems. This machine is designed and built with user safety in mind; however, it can present hazards if improperly operated and serviced. Please follow the operating instructions carefully. If there are any questions regarding operating or servicing of this machine, please contact DiamaPro® Systems.

Disclaimer: DiamaPro® Systems and its affiliates take no responsibility for any damage, injury or death resulting from the incorrect or unsafe use of this product. Use of this product should be undertaken by competent persons only. It is the operator's responsibility to ensure that the following safety procedures are followed. If you are unsure, do not operate this product.

## 1. SAFETY INSTRUCTIONS

### 1.1 KNOW THE RULES & YOUR EQUIPMENT

Most job sites have rules governing equipment use & maintenance. Before starting at a new work location, check with the supervisor or safety coordinator. Ask about any rules or regulations you need to abide by. OSHA enforces federal laws within the United States that apply to the safe operation, application, & maintenance of equipment on job sites. It is the employer's responsibility to comply with these laws. Do not operate this machine unless you carefully read the operations and maintenance manual.

### 1.2 RECEIVE PROPER TRAINING

Do not operate this machine unless you have received operational and maintenance training from a DiamaPro® Systems representative or from an authorized distributor for DiamaPro® Systems

### 1.3 PROTECT YOUR FEET

Observe all applicable local, state and federal safety regulations. Wear OSHA approved foot protection.

### 1.4 PROTECT YOUR EYES

Observe all applicable local, state and federal safety regulations. Wear OSHA approved safety glasses.

### 1.5 PROTECT YOUR LUNGS

Breathable silica may be generated by use of this product. Silica can cause severe and permanent lung damage, cancer, and other serious diseases. Do not breathe the dust. Do not rely on your sight or smell to determine if dust is in the air. Silica may be in the air without a visible dust cloud. If air monitoring equipment for silica is not provided by your employer at your work site, you MUST wear appropriate respiratory protection when using or servicing the machine. Consult your employer and OSHA regarding the appropriate respiratory protection.

### 1.6 PROTECT YOUR EARS

Observe all applicable local, state and federal safety regulations. Wear OSHA approved hearing protection.

### 1.7 DRESS PROPERLY

Do not wear loose clothing or jewelry that can be caught in moving parts. Wear protective hair covering to contain long hair. Keep hair away from motor air vent. Rubber gloves and non-skid footwear are recommended when working outdoors.

### 1.8 AVOID A DANGEROUS ENVIRONMENT

Do not expose machine to rain. Do not use machine in wet conditions. Keep work area well lit. When working at an elevated location, pay attention to articles and persons below.

### 1.9 BEWARE OF HIDDEN DANGERS IN CONCRETE

Rebar or utility lines may be buried in concrete. Disconnect the power to any utility lines. If these dangers are present are to be missed, clearly mark the area.

### 1.10 KEEP WORK AREA CLEAN - DO NOT RUN OVER ANYTHING

Loose debris could be thrown from crack. Make sure area to be cut is clear from people and any loose objects, nuts, bolts, etc. Never run over any loose objects.

### 1.11 KEEP CHILDREN AND VISITORS AWAY

Do not allow anyone to stand in line with the grinding path. Do not let children or visitors in contact with machine or extension cord. Keep children and visitors away from the work area.

### 1.12 AVOID FLAMMABLE LIQUIDS OR GASES

Diamond Tooling produce heat and sparks during operation. Never use machines in dangerous sites containing flammable, combustible or explosive materials such as lacquer, paint, benzene, thinner, gasoline, gases, and adhesive agents.

### 1.13 AVOID CONTACT WITH HOT TOOLING AND SHROUD

The Diamond tooling and shroud become hot during operation and remain hot after stopped. Do not touch the tooling and shroud without proper hand protection.

### 1.14 KEEP FIRM GRIP ON MACHINE

Keep a firm hold on the handle grips and maintain control of the machine until the grinding completely stops.

### 1.15 CHECK TOOLING FOR CRACKS, DAMAGE, AND MISALIGNMENT

Never use a cracked, damaged, or misaligned tooling. After mounting check to see tooling is secure.

### 1.16 DO NOT FORCE WRONG SIZE OR TYPE OF TOOLING ONTO MACHINE

Running the wrong type/size of tooling can cause damage to your machine

### 1.17 USE EQUIPMENT AND ACCESSORIES PROPERLY

Do not force a small grinder to do the job of a heavy-duty grinder. Do not use the walk-behind grinder for improper applications. Never cut material for which the tooling was not designed.

### 1.18 STORE IDLE EQUIPMENT

The machine and tools should be stored in a dry and secure location when not in use. Keep equipment out of reach of children.

### 1.19 DO NOT FORCE

The grinder will do the job better and safer at the rate for which it was designed.

### 1.20 OBTAIN MATERIAL SAFETY DATA SHEET (MSDS) FOR ALL WORK SURFACE MATERIALS

This includes primers, all coatings, adhesives, tile and crack filling materials, etc. Do not attempt to cut, clean out or remove material without MSDS information. Consult MSDS sheet for hazards information. Be aware that some materials are explosive such as dust.

### 1.21 DO NOT OVERREACH

Always keep proper footing and balance.

### 1.22 MAINTAIN MACHINE WITH CARE

Keep machine clean and follow maintenance procedures for better and safer performance. Keep handles dry, clean, and free from oil and grease. Follow instructions for lubricating and changing accessories.

## 1.23 REMOVE ADJUSTING TOOLS

Form a habit of checking to see that tools such as adjusting wrenches are removed from the machine and properly stored before starting.

## 1.24 STAY ALERT

Watch what you are doing. Use common sense. Do not operate machine when you are tired or fatigued.

## 1.25 DO NOT USE DRUGS, ALCOHOL, MEDICATION

Do not operate machine while under the influence of drugs, alcohol, or any medication.

## 1.26 KEEP ALL PARTS IN CORRECT POSITION

Do not operate machine with missing or improperly mounted parts.

## 1.27 CHECK DAMAGED PARTS

Verify all machine guards are in good condition and will function properly before using the machine. Check for alignment of moving parts, binding of moving parts, breakage of parts, mounting, and any other conditions that may affect machine operation. A guard, power switch or other part that is damaged should be properly repaired or replaced by an authorized service center.

## 1.28 NEVER TOUCH MOVING PARTS

Never touch moving parts such as blades, belts, and others.

## 1.29 STOP OPERATION IMMEDIATELY IF ANY ABNORMALITY IS DETECTED

Stop using machine immediately if any abnormalities are observed during operation. Examples of abnormalities include unusual noise and vibration

## 1.30 WHEN REPLACING A PART, USE THE SAME TYPE AND QUALITY

When replacing a component part with a new one, use only the same type and quality of the previous part. Never attempt to repair a machine if you are unfamiliar with proper procedures and techniques required. Refer to this operations and maintenance manual as well as any additional instructions included from other manufacturers.

## 1.31 LEVELING THE DX22-P

1. Turn the machine off and disconnect the battery
  - a. Using the footplate, tilt the machine back and rest it on its kickstand.
    - i. Be sure the machine is balanced and will not tilt forward. Do not be under the machine while it is tilted back.
2. Install tooling to tool plates
  - a. Be sure the tooling is fully seated against the grinding/tool plates and is sitting flat.
    - i. If needed, remove any debris from the grinding/tool plates using a wire brush. Any debris that will impede the tool from lying flat can cause unwanted surface profiles.
  - b. Install Tool retention bolts
3. Set machine down on a flat and level surface.
4. Level the machine using the Leveling Hand Wheel (1) and the Bubble Level (2) [Figure 1].

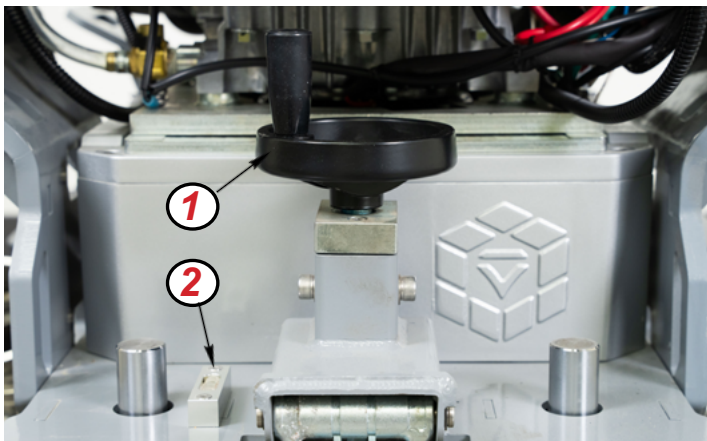

Figure 1

- a. To raise the rear of the machine, turn the leveling wheel counter-clockwise
- b. When the bubble is toward the front of the machine (Figure 2), spin the leveling wheel Counter-clockwise to move it toward the center.



Figure 2

- c. When the bubble is toward the back of the machine, spin the leveling wheel clockwise to move it toward the center (Figure 3).



Figure 3

- d. Raise/Lower the rear of the machine until the Bubble in the sight is centered (Figure 4).



Figure 4

## 1.32 SAVE THESE INSTRUCTIONS

Refer to this operations and maintenance manual as well as any additional instructions included from other manufacturers.

## CALIFORNIA PROP 65 WARNING

Thank you for purchasing a DIAMAPRO® SYSTEMS product. This manual provides information and procedures to safely operate and maintain the DiamaPro® DX22-P. For your own safety and protection from injury, carefully read, understand, and observe the safety instructions described in this manual. Keep this manual or a copy of it with the machine. If you lose this manual or need an additional copy, please contact DiamaPro® Systems. This machine is designed and built with user safety in mind; however, it can present hazards if improperly operated and serviced.

Please follow the operating instructions carefully. If there are any questions regarding operating or servicing of this machine, please contact DiamaPro® Systems.



**THIS PRODUCT CONTAINS LEAD, A CHEMICAL KNOWN TO THE STATE OF CALIFORNIA TO CAUSE BIRTH DEFECTS OR OTHER REPRODUCTIVE HARM.**



**THIS PRODUCT CONTAINS ONE OR MORE CHEMICALS KNOWN TO THE STATE OF CALIFORNIA TO CAUSE CANCER, BIRTH DEFECTS OR OTHER REPRODUCTIVE HARM.**



**EXHAUST GASES FROM THIS PRODUCT CONTAIN CHEMICALS KNOWN TO THE STATE OF CALIFORNIA TO CAUSE CANCER, BIRTH DEFECTS OR OTHER REPRODUCTIVE HARM.**

### CALIFORNIA PROP 65 WARNING

Use of this product can cause exposure to materials known to the State of California to cause cancer and/or birth defects or other reproductive harm.



### CAUTION

**Respirable crystalline silica. May cause cancer. Causes damage to lungs.  
Wear respiratory protection during exposure.  
Use appropriate dust control equipment to keep dust within OSHA  
and local regulation limits.**



## WARNING & ATTENTION

### WARNINGS

- Please check the fastening of each component of the propane gas system before use, tighten loose fasteners, and check whether there is leakage at the gas cylinder, pipeline, and connection, and do not operate the equipment and repair if there is any leakage
- Proper selection of propane fuel or poor fuel quality will cause engine failure and affect the normal operation of the engine.
- Do not use tools or other metal objects to contact the two terminals of the battery, and do not short-circuit the positive and negative terminals of the battery, as there is a danger of explosion. The connection of battery terminals should be firm. When the terminal is loose, there is a danger of explosion when a spark occurs due to poor contact. Damaged cables and wires can cause a fire. Check and replace before reconnecting.

### ATTENTION

- Avoid splashing water on the engine and control box during machine cleaning
- Never do maintenance on any part of the fuel system while the engine is running
- If the machine does not appear to be operating properly, it should be shut down.
- Ensure that the tools are installed in place and securely

## DUST WARNING

**Cutting, especially when DRY cutting, generates dust that comes from the material being cut, which frequently contains silica. When dry cutting, be sure to use a HEPA filtered dust collector.**

Silica is a basic component of sand, quartz, brick clay, granite and numerous other minerals and rocks. Exposure to excessive amount of such dust can cause:

- Respiratory diseases (affecting your ability to breath), including chronic bronchitis, silicosis and pulmonary fibrosis from exposure to silica. These diseases may be fatal;
- Skin irritation and rash; and
- Cancer according to NTP\* and IARC\*

\*National Toxicology Program, International Agency for Research on Cancer

Take precautionary steps

- Avoid inhalation of and skin contact with dust, mist and fumes;
- Wet cut when feasible, to minimize dust;
- Wear and ensure that all bystanders wear appropriate respiratory protection such as dust masks designed to filter out microscopic particles. (See OSHA 29 CFR Part 1910.1200)

## CARBON MONOXIDE WARNING

### OPERATING ENVIRONMENT

The DiamaPro® DX22-P can be operated outdoors within the temperature range of 41°F to 86°F (5°C to 30°C). It's crucial to avoid using the machine during rainy or snowy weather conditions. When using the machine indoors, make sure to work in areas that are adequately ventilated.

### PROTECTION DEVICES

The machine is equipped with multiple safety mechanisms, including: a protective skirt and a hood that shield the tool plates. These contrivances safeguard the operator and any other individuals from potential harm. It is imperative not to remove them. Instead, prior to utilizing the machinery, ensure that all safety devices are appropriately installed and operational.

### USAGE SAFETY

The DiamaPro® Systems DX22-P is intended to minimize all associated hazards related to its operation. Nonetheless, it is not entirely feasible to eliminate the possibility of accidents with the machine. Inexperienced or untrained operators may cause residual risks associated with:

- Positional hazards due to improper operator posture
- Entanglement hazards arising from the use of unsuitable work attire
- Training hazards caused by insufficient operational training

### SAFETY MEASURES FOR PROPANE

Propane is a flammable gas with vapors that are denser than air. Similar to gasoline, improper handling of propane can lead to explosions. To aid in detecting leaks, propane is mixed with an odorant that has a distinctive smell, detectable at low concentrations. When working with propane, it is essential to be aware and take necessary safety precautions. As long as these measures are observed, the risk is minimal. However, lack of awareness could result in needless hazards. The two most significant dangers associated with propane-powered floor care machines are:

- Carbon Monoxide Poisoning:  
Carbon monoxide poisoning is the most commonly reported incident associated with propane-powered floor care machines, caused by excessive exhaust emissions. The symptoms include headaches, dizziness, and nausea. Engines with inadequate preventive maintenance practices, particularly those with unclean air filters and machines operated in enclosed spaces without sufficient ventilation, are a significant cause. The use of substandard, inexpensive machines without emissions control technology and improperly adjusted carburetion could also contribute to the problem.
- Overfilled Fuel Cylinders:  
Almost all fire-related incidents reported occur when a cylinder is brought into a building without first checking for overfill. This practice is hazardous, imprudent, and avoidable.

### SAFETY AGAINST FIRE

Be mindful of the potential risks of fire or explosion when working with propane and take standard fire-safety measures.

- Fire:  
There is a likelihood of fire resulting from leakage or venting of LPG vapor from fuel cylinders or carburetion equipment.
- Explosion:  
Concentration or confinement of LPG vapor in a restricted or small space may cause ignition or explosion.  
Propane may also experience a BLEVE: Boiling Liquid Expanding Vapor Explosion.

### EMISSIONS

All propane-powered floor care machines generate emissions. While most are innocuous, some can be hazardous, even fatal. Carbon monoxide (CO) presents the most significant danger since exposure to CO at a concentration of 3,000 parts per million (ppm) for as little as 30 minutes can be lethal. Carbon monoxide is a colorless, odorless, and invisible gas formed when fossil fuels, including propane, gasoline, wood, coal, oil, and methane, burn incompletely.

## AGENCIES AND REGULATIONS

### ■ National Fire Protection Agency (NFPA)

To operate a propane-powered floor care machine safely, it is necessary to adhere to specific safety regulations. The NFPA is responsible for ensuring safe propane use and storage, and their Standard for Storage and Handling of LP Gas should be consulted for guidance. Copies of this publication can be obtained by contacting the NFPA in Quincy, MA at 1-800-334-3555.

One important regulation set forth by the NFPA #58 is that all personnel who handle propane gas must be properly trained in its safe handling and operation procedures and carry a certification from their employer or training supervisor attesting to this fact. While this requirement primarily applies to individuals who fill and transport liquid propane gas, DiamaPro® Systems recommends that operators of propane-powered floor care machines in public areas also receive proper training and certification. Although NFPA 58 8-4.5 permits the use of propane-powered floor care equipment in buildings frequented by the public, including when they are occupied, DiamaPro® Systems suggests that these machines be used when occupancy is minimal.

### ■ California Air Resource Board (CARB) & Environmental Protection Agency (EPA)

While CARB and EPA establish limits for propane-powered engines used outdoors, it is important to note that approval from CARB/EPA does not indicate that the engine is safe for indoor use.

### ■ Canadian Gas Association (CGA)

A limit of 1500 ppm CO in exhaust flow has been established by the CGA.

### ■ Occupational Health and Safety Administration (OSHA)

When it comes to propane-powered machines utilized indoors, OSHA has implemented an 8-hour time-weighted average (TWA) limit of 50 ppm CO in ambient air. OSHA is also contemplating the establishment of a limit of 800 ppm CO in exhaust flow.

### ■ Department of Transportation (DOT)

Regulations have been set forth by the DOT regarding the safety of fuel cylinders, including those utilized on propane-powered floor care machines.

### ■ Local Agencies

Before granting approval for the use of certain equipment, local law enforcement agencies such as the Fire Marshall may rely on independent testing laboratories like UL and CGA. These labs conduct extensive testing of equipment and only issue their approval after a rigorous evaluation process. While not mandatory for all law enforcement agencies, the stamp of approval from these organizations serves as an additional assurance for operators that they are working with and around safe equipment.

## PERSONAL PROTECTIVE EQUIPMENT

When operating the machine, it is important to:

- Wear safety shoes at all times.
- Wear ear protectors to safeguard your hearing.
- Ensure that all personnel in the immediate work area wear safety glasses with side shields.
- Wear safety gloves when changing tools.
- Dress appropriately for the work environment.
- Use Carbon Monoxide monitors.

## TESTING:

Numerous tools are available in the market for detecting toxic gases. However, only the ones specifically designed for detecting carbon monoxide resulting from combustion engines are deemed suitable for testing exhaust emissions from floor machines powered by propane. Certain instruments are meant for detecting "ambient air" and may get damaged if utilized for taking readings in the muffler or tailpipe. Hence, it is crucial to select the appropriate instrument to fulfill the testing requirements. In general, instruments that can detect readings in ppm (parts per million) ranging from 0 to 1000 are sufficient for examining ambient air, i.e., the air in the breathing zone of the operator. On the other hand, devices capable of testing carbon monoxide in the exhaust should be certified by the manufacturer for that purpose and should be able to read from 0 to at least 2000 ppm.

Several instruments and systems for these purposes include:

### 1. AMBIENT AIR MONITORING

- DRAGER Model 190 manufactured by National Drager
- SENSIDYNE gas sampling system with YB-11038 Sensidyne detector tubes
- DRAGER gas sampling system with YB-4620 Drager detective tubes
- GAS-TECH Model CO-95
- ENERAC POCKET 60 manufactured by Energy Efficiency System

### 2. ENGINE EXHAUST ANALYZERS

- HORIBA GAS ANALYZER
- ENERAC 2000 COMBUSTION ANALYZER
- ENERAC POCKET 60

### 3. DATA LOGGERS

- INDUSTRIAL SCIENTIFIC CORP. MODEL STX-70 CO MONITOR, Data-Logger
- BIOSYSTEMS INC. "TEXILOG" Data-Logger

All instruments used for testing must be calibrated at the intervals recommended by the manufacturer. The test results must include the monitor's model number and date of calibration.

## 2. MAINTENANCE & REPAIR



Before carrying out the maintenance of the DX22-P make sure you understand the contents of this manual. Please contact DiamaPro® Systems for further explanations and information.

- The user shall be required to comply with the qualifications of the relevant personnel:



### OPERATOR / ORDINARY MAINTENANCE TECHNICIAN:

carries out the tasks necessary for the basic functioning of the machine: execution of the work cycle, implementation of operator commands, other operations closely linked to normal production, any cleaning and inspection operation performed on a daily basis, enforcement of ordinary maintenance operations. Works only with enabled safety functions.



### MAINTENANCE TECHNICIAN SPECIALIST (AUTHORIZED DEALER)

Involved in all operating conditions and at all protection levels. Makes extraordinary operations that cannot be run by the user

Maintenance technicians must possess the skills required by this manual, as well as the mental and physical requirements necessary and sufficient to maintain and operate the machine. To ensure the functionality and durability of the machine daily maintenance must be performed, carrying out operations in compliance with the safety requirements.

Only the authorized dealer can make adjustments and operations that are not assigned to the operator. It is forbidden to make adjustments and interventions during machine operation. Before performing any maintenance operation disconnect the machine from the power sources and wait for the cooling of the hot parts (engine, spark-plug area, air filter area, etc.)

- Disengage the Clutch
- Bring the accelerator at idle speed.
- Close the propane tank valve.
- Stop the engine (position the ignition key to OFF).
- Turn battery switch to the off position
- Carry out maintenance operations with the machine stopped.
- Allow machine to properly cool off

Before performing maintenance:

- Thoroughly clean the DX22-P. If in doubt about how to perform occasional repairs, contact our Technical Support or an authorized dealer.
- Upon finishing the job perform a thorough cleaning from processing residues.

### 2.1 SCHEDULED MAINTENANCE

Good maintenance requires constant and methodical control of all parts of the machine and adaptation of tests to its actual usage. Periodic inspections are crucial to keep the machine efficient and reduce repairs and any resulting dangers.

We recommend that you have your DX22-P serviced by an authorized dealer or a DiamaPro® Systems technician every 500 hours.

Note: frequency is taken over considering a working day of 8 hours.

### 2.2 ROUTINE & ADDITIONAL MAINTENANCE



#### Replacement of the clutch belt

If, as a result of a visual inspection, it appears that the belts are worn or cracked, replace them, operating as follow:

- Allow motor to cool before replacing belts
- Remove side plate located on opposite side from the battery shut off
- Loosen the six bolts on the motor mount plate
- Loosen the belt tension screw on the front under the exhaust to relieve tension to remove belt
- Remove belt under the clutch and over the gearbox pulley
- Install new belt the same way, over the gearbox pulley and under the clutch
- Set tension back with tension bolt
- Tighten 6 side bolts on motor mount plate
- Reinstall side plate

### LOWER V-BELT CHANGE

TOOLS NEEDED:

- M5 Allen Socket
- M6 Allen Socket
- M10 Allen Socket
- 17mm Socket/Wrench
- Blue Loctite
- Belt Tension Measuring Device

PROCESS:

1. Be sure Machine is off and disconnected from all fuel/spark sources. While removing belts be aware of extremities while parts are still warm.
2. Remove the side covers from the transmission casing.
  - a. Once the covers are removed, loosen the transmission mounting bolts with a 17mm socket.
  - b. In some cases, the gearbox cover may need to be removed first.
    - i. Follow steps 3a-3c to remove the front cover.
3. Remove the transmissions front cover.
  - a. Use an M5 Allen to remove the countersunk bolts from the front cover.
  - b. Remove the front socket head bolt from the transmission holding the tie down flanges to the machine.
  - c. Remove the front gearbox cover mounting bolts with an M5 Allen
  - d. Remove the front cover.
  - e. Remove the gearbox top cover from the frame.
  - f. On the rear of the machine, to the left of the kickstand, loosen the M10 bolt to relieve tension on the lower pulleys.
  - g. Once enough tension has been released, slide the Belts one at a time beneath the intermediate pulley, and remove the belts from the machine.
4. Loosen Lower Pulley Tensioning Bolt
  - a. On the rear of the machine, to the left of the kickstand, loosen the M10 bolt to relieve tension on the lower pulleys
  - b. Once enough tension has been released, slide the Belts one at a time beneath the intermediate pulley, and remove the belts from the machine.
5. To install new Belts, Complete this process in reverse.
  - a. Install new Belts onto the lower pulley.
  - b. Be sure to properly tension the new belts.



#### Engine oil filling

Refer to the engine manual and the MAINTENANCE SECTION. The oil filling must be performed with the machine off after hot parts have cooled.

- Remove oil fill cap
- Remove valve lock and set aside
- Lower oil drain tube into an oil containment vessel and remove cap
- Unlock valve and let oil drain
- Once oil has drained, remove oil filter
- Install new oil filter, place fresh oil around filter seal before installing
- Close valve & replace lock

**IMPORTANT!**  
**TO AVOID DAMAGE TO THE MACHINE**  
**STRICTLY follow the engine manufacturer's recommended oil in the manual provided with the machine. 10W-30 is recommended.**

- Add oil. Check level on dipstick.
- Tighten oil fill cap
- Check for any leaks

**IMPORTANT!**  
**To avoid damage to the engine and/or throttle assembly, disconnect the throttle cable from the throttle assembly when tilting the frame back for maintenance.**

## 2. MAINTENANCE & REPAIR

### Oil Viscosity

Choose the viscosity according to the temperature as follows:

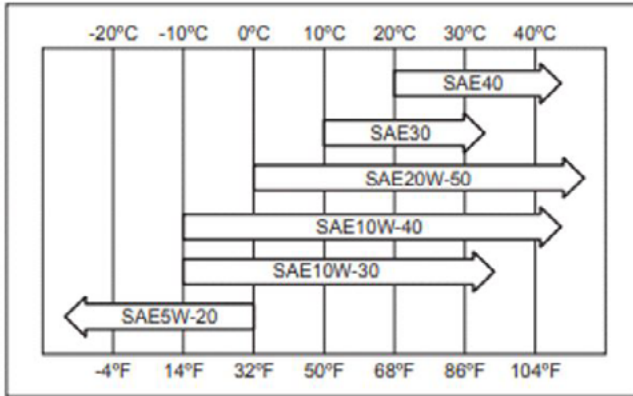

#### NOTE

Although 10W-30 engine oil is the recommended oil for most conditions, the oil viscosity may need to be changed to accommodate atmospheric conditions. Please contact the authorized dealer if running machine in extreme conditions for the correct oil choice.



### Battery

If not using the machine for a period of time, disconnect the battery utilizing the quick disconnect cables.

#### IMPORTANT!

Only recharge the battery in a dry environment. Protect the contacts from dirt and moisture stagnation. Don't spray with water.

### Battery replacement

1. Remove the enclosing lid by removing the retaining screw.
2. Disconnect the battery by means of the quick disconnects.
3. Remove the connection terminals (1) and (2) taking care to remove first the negative, black color (1) in order to avoid a possible short-circuit.
4. Remove the battery and replace it with another one having the same characteristics.



### Battery change and maintenance

Be sure terminals are covered with terminal boots as shown in "Figure 3."



When charging the battery, ALWAYS remove and disconnect from the DX22-P. Failure to do so may cause damage to the machine

#### IMPORTANT

- ! Replace only with manufacturer recommended battery (P/N: W4359)
- Use of non-OEM Battery May result in harm to user, damage to the machine, and/or violation of the machine's warranty.

### 2.3. NOTES ON DISMANTLING

As regards dismantling activities there are no security-related or environmental problems. In case you wish to proceed with the dismantling of the various machine parts, it is necessary to pay attention to their movement taking into account the respective masses to be handled. In case of machines used in working environments it's necessary to dispose of the electrical and electronic products, if any, contained in them in accordance with the current legislation.

#### IMPORTANT

- ! Do not dispose into the environment products which are not biodegradable, lubricant oils and relevant filters as well as non-ferrous parts (rubber, PVC, etc.). Perform their disposal in accordance with the laws in force and before taking care of this disposal, consult your authorized dealer in order to check whether there are specific programs of withdrawal.











#### IMPORTANT

- ! At the time of dismantling, the user shall be required to recover the identification plate of the equipment to prevent the machine from being put back into service without its guards because the MANUFACTURER IS NO LONGER HELD RESPONSIBLE.









## 2. MAINTENANCE & REPAIR (cont).

FREQUENCY	PROCEDURES
FIRST 8 HOURS (BREAK IN PERIOD)	-CHANGE OIL & OIL FILTER -INSPECT CLUTCH BELT TENSION -TILT MACHINE BACK AND INSPECT GEARBOX SEALS AROUND EACH GRINDING HEAD
EVERY 50 HOURS	-CHANGE OIL & OIL FILTER -CHECK & CLEAN OIL COOLER FINS
EVERY 100 HOURS	-REPLACE SPARK PLUGS -INSPECT CLUTCH BELT TENSION
EVERY 250 HOURS	-CHECK BATTERY WITH LOAD TESTER. REPLACE IF NEEDED -REPLACE PRIMARY & SECONDARY AIR FILTER -CHECK VALVE CLEARANCE. ADJUST IF NEEDED.
EVERY 250 HOURS	-INSPECT RUBBER IN FLEXIBLE TOOL PLATE MOUNT FOR DAMAGE OR EXCESSIVE WEAR. REPLACE AS NEEDED
EVERY 500 HOURS	-REPLACE CLUTCH BELT
EVERY 1000 HOURS	-INSPECT ELECTROMAGNETIC CLUTCH. REPLACE IF NEEDED. -INSPECT ANTI-ROTATION. REPLACE IF NEEDED -REPLACE GEAR OIL

NAME OF OPERATION	FREQUENCY	PERSON IN CHARGE	OPERATING INSTRUCTIONS	STATE OF MACHINE
<b>MECHANICAL PARTS</b>				
<b>General Cleaning</b>	At each start		Wash the dirty parts with a brush and water. Lubricate the parts exposed to dust; Do not lubricate the rubber parts subjected to motion (belts, etc).	Machine stopped /Power sources disconnected
<b>Engine Air Filter</b>	At each start		Check and Clean engine air filter if necessary, especially if you are working in dusty conditions or replace it; follow the instructions given in the engine	Machine stopped /Power sources disconnected
<b>Grinding Heads</b>	At each start		Lift the gearbox grinding head, check whether the abrasive positioning pins are loose or damaged, and replace them if necessary	Machine stopped /Power sources disconnected
<b>Engine Oil Level</b>	At each start		Add oil if low or replace oil & oil filter if needed	Machine stopped /Power sources disconnected
<b>Wheels &amp; Wheel Bearings</b>	At each start		Inspect wheels & wheel bearings for damage or excessive wear. Replace if needed.	Machine stopped /Power sources disconnected
<b>Dust Control System</b>	At each start		Inspect dust skirt and dust hoses for damage or excessive wear. Replace if needed.	Machine stopped /Power sources disconnected
<b>Check Propane Level &amp; Supply</b>	At each start		<b>It is recommended to make sure that the propane contains no water and not to use mixtures or diesel. Perform this operation in a well-ventilated environment and away from possible sources of heat or flames. Make use of specific P.P.E. (mask) as shown in the residual risks table of this publication. REFER TO THE ENGINE MANUAL</b>	Machine stopped /Power sources disconnected
<b>Battery</b>	Weekly Or every 40 hours		The DX22-P is equipped with a maintenance-free battery. DO NOT TRY TO FILL. Clean the two battery poles to remove oxidation. It is recommended to turn off the battery via the circuit breaker on the side of the grinder when storing or transporting the machine	Machine stopped /Power sources disconnected

## 2. MAINTENANCE & REPAIR (cont).

NAME OF OPERATION	FREQUENCY	PERSON IN CHARGE	OPERATING INSTRUCTIONS	STATE OF MACHINE
<b>MECHANICAL PARTS</b>				
<b>Gearbox</b>	Weekly Or every 40 hours		<p>The gearboxes are sealed upon assembly; if you notice oil leaks, carefully find out their origin because there may be leaks from other sources. If the leaks come from the gearbox, contact our technical service or a qualified technician.</p> <p>Clean any oil leaks at the bottom of the grinder. For a possible change of the lubricant due to leaks or for the topping up operations, use the following type of lubricant: MOBIL SCH 630</p> <div style="border: 1px solid black; padding: 5px; background-color: #f0f0f0;"> <p style="text-align: center;"><b>CAUTION</b></p> <p style="text-align: center;"><b>DO NOT REPLACE THE GEARBOX. CONTACT DIAMAPRO® SYSTEMS OR THE AUTHORIZED DEALER.</b></p> </div>	Machine stopped /Power sources disconnected
<b>Oil Cooler</b>	Weekly Or every 40 hours		Check & clean any dust or debris, especially if you are working in dusty conditions	Machine stopped /Power sources disconnected
<b>Spark plugs</b>	Weekly Or every 40 hours		<p>Inspect Spark Plugs. If you need a replacement, refer to the engine manual.</p> <p>Be careful when removing the spark plug:</p> <ul style="list-style-type: none"> <li>• wait for the engine to cool down;</li> <li>• remove the cap;</li> <li>• remove the spark plug down away from the spark plug holder (because spark may be triggered).</li> </ul>	Machine stopped /Power sources disconnected
<b>Clutch Belt</b>	Weekly Or every 40 hours		Check belt for proper tension or abnormal wear. Replace if needed	Machine stopped /Power sources disconnected
<b>SAFETY SYSTEMS</b>				
<b>Safety Systems</b>	Daily		Please note the requirement to perform the checking and recording of verifications of safety components every 6 months.	Machine Stopped
<b>Integrity of Pictograms</b>	Weekly Or every 40 hours			Machine stopped /Power sources disconnected

# CARRIAGE ASSEMBLY

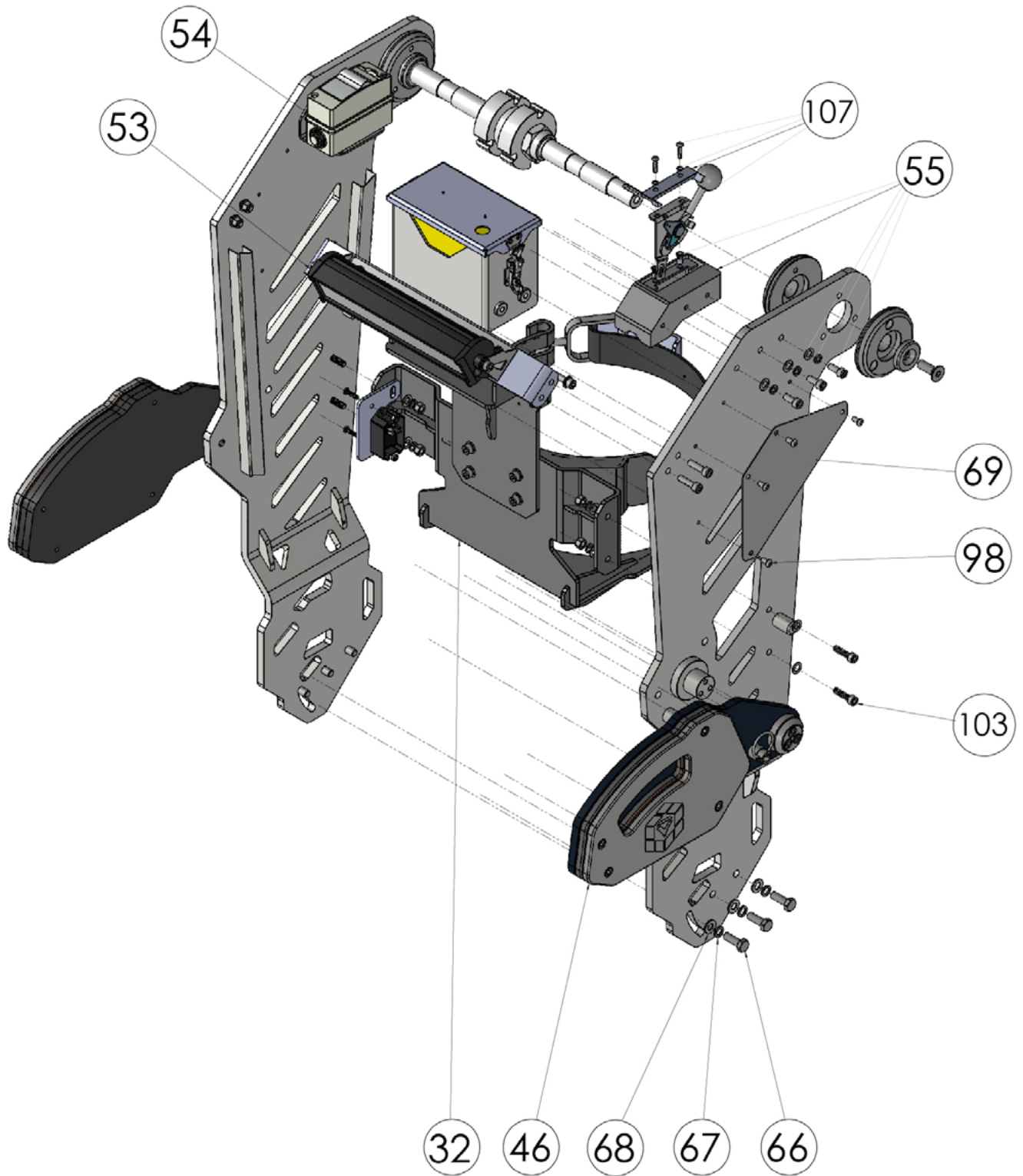

## CARRIAGE ASSEMBLY

ITEM NO.	PART NUMBER	DESCRIPTION	QTY.
32	<b>SEE SUB-ASSEMBLY</b> (pg. 18)	Tank Bracket Sub-Assembly	1
46	<b>SEE SUB-ASSEMBLY</b> (pg. 14)	Weight Arm Sub-Assembly	1
53	<b>SEE SUB-ASSEMBLY</b> (pg. 17)	LED Light Bracket Sub-Assembly	1
54	DP-DX-BBOX	DX Breaker Box	1
55	DP-DX22-THRM-K	DX22-P Throttle Mount Assembly Kit	1
66	DP-GH-DX0282	M10 X 30 Bolt	6
67	DP-GH-DX0277	M10 Split Washer	6
68	DP-GH-DX0281	M10 Flat Washer	6
69	DP-DX22-P-LGLL	DX22-P Logo Name Plate	2
98	DP-GH-DX0285	M6 X 12 Button Head Hex Bolt	8
103	DP-GH-DX0267	M8 x 30mm Socket Head Bolt	2
107	DP-GH-DX0267	DX22-P Throttle Kit	1
NP	DP-DX-BTBR	63 Amp Breaker	1
NP	DP-DX-BYSW	10 Amp Breaker	1

# TOOL PLATE ASSEMBLY

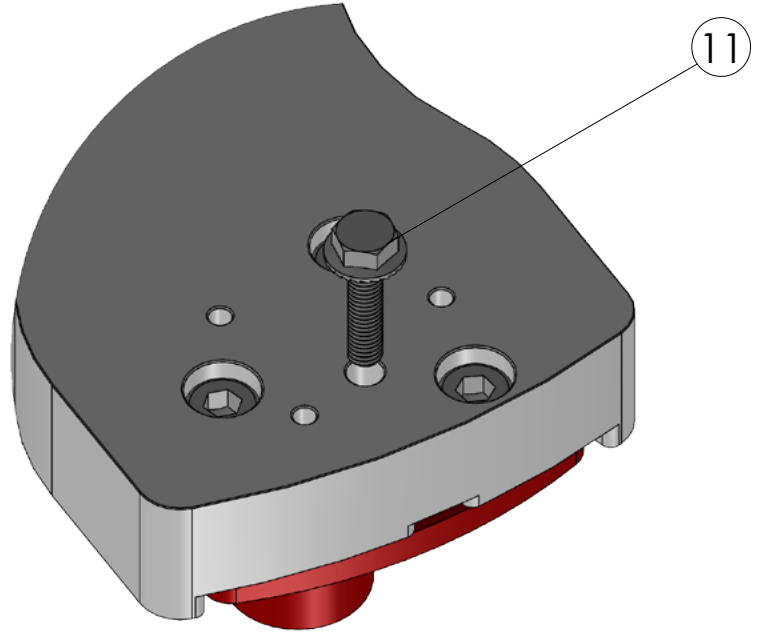
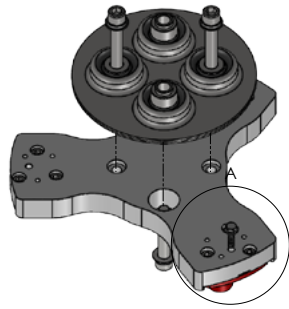

ITEM NO.	PART NUMBER	DESCRIPTION	QTY.
11	DP-GH-RTSY	M6 Hex Bead Serrated Bolt	3

# WEIGHT ARM ASSEMBLY

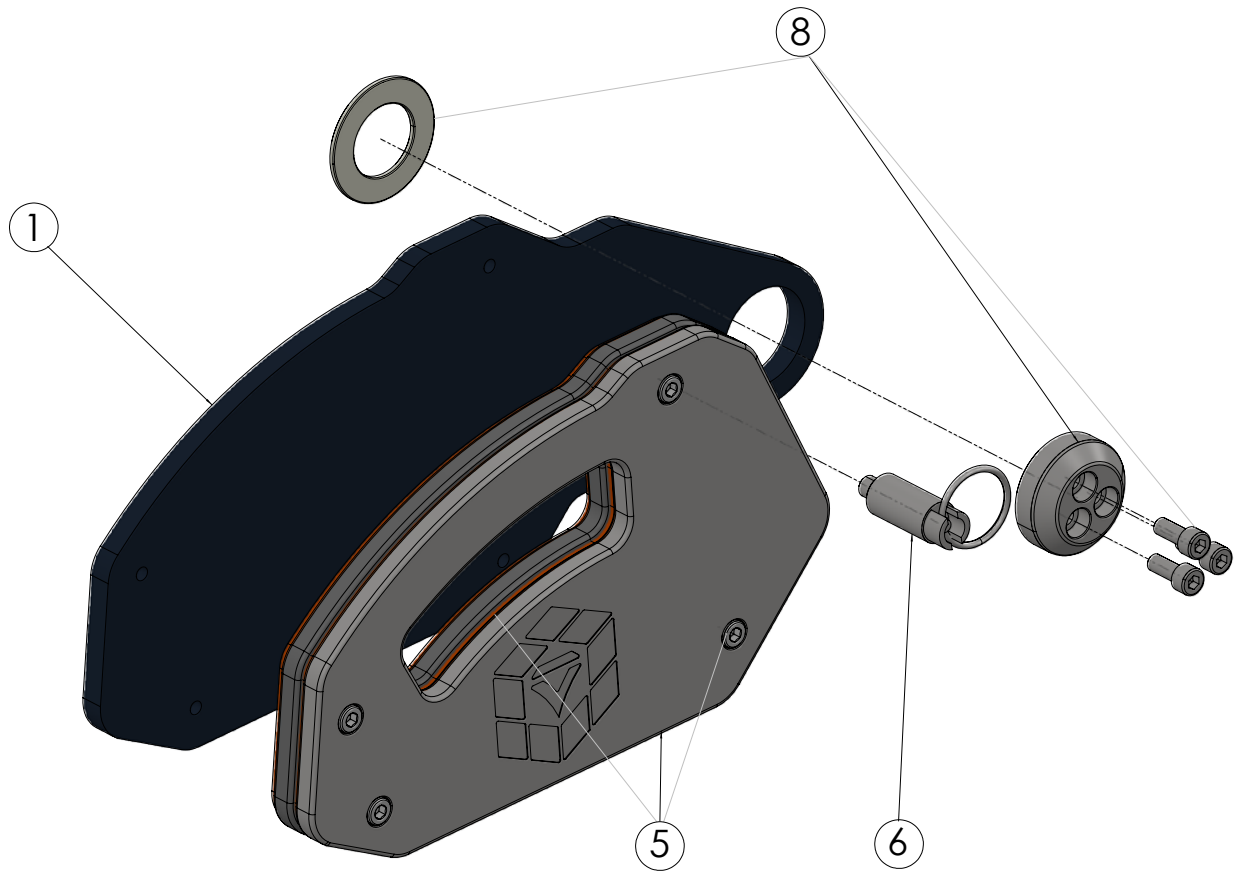

ITEM NO.	PART NUMBER	DESCRIPTION	QTY.
1	DP-DX22-WARM	Weight Arm	2
5	DP-DX22-L-WGHT-K	Left Side Weight Kit	1
NP	DP-DX22-R-WGHT-K	Right Side Weight Kit	1
6	DP-DX22-WALP	Weight Arm Locking Pin M20X1.5	2
8	DP-DX-WAP-K	Weight Arm Plug Kit	2

# ENGINE AND TRANSMISSION ASSEMBLY

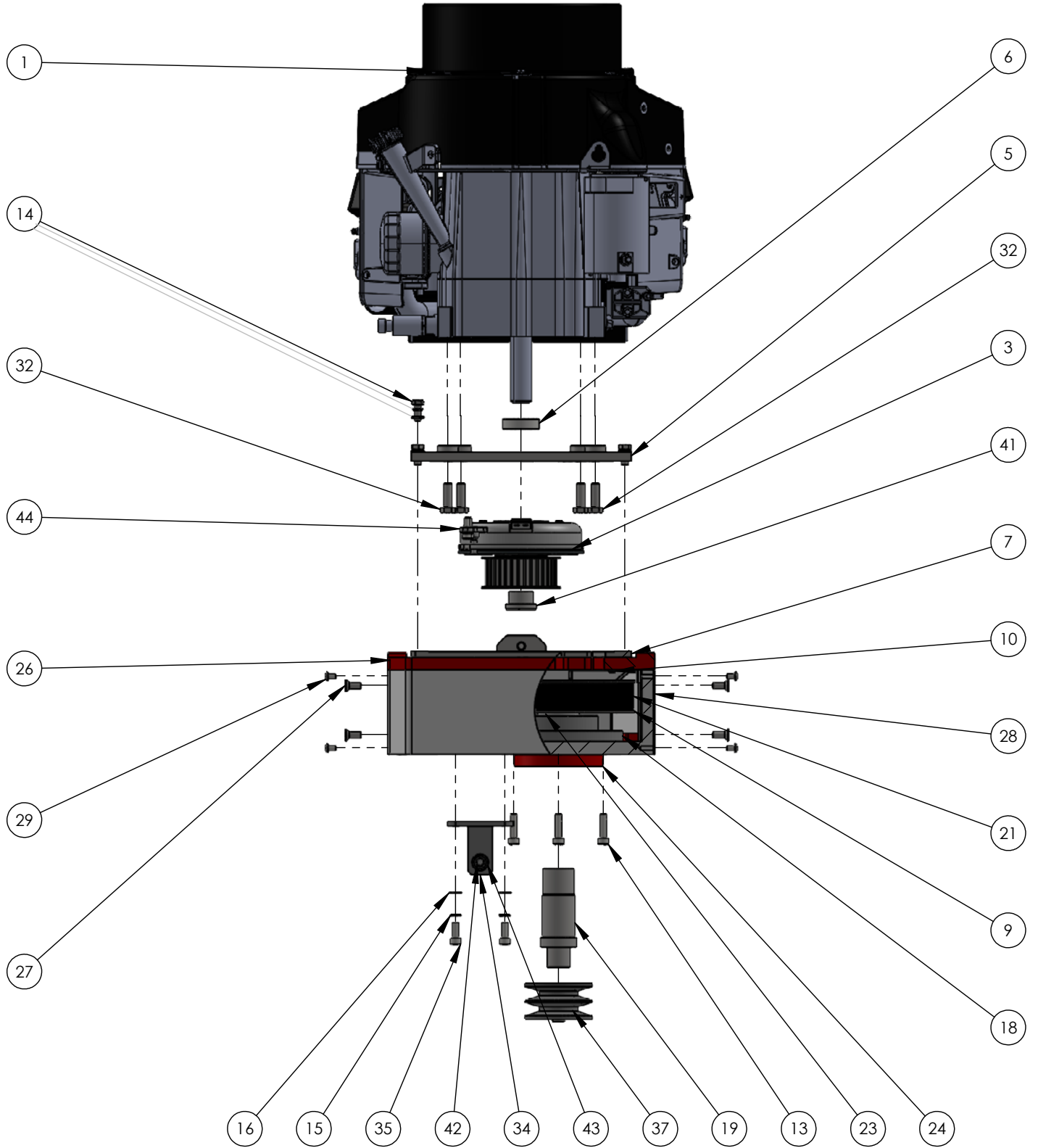

## ENGINE AND TRANSMISSION ASSEMBLY

ITEM NO.	PART NUMBER	DESCRIPTION	QTY.
1	LX600-S008	17 HP Kawasaki Engine	1
3	DP-EMC-5219	1" Bore Electro Magnetic Clutch	1
5	DP-DX22-ENMP	Engine Mounting Plate	1
6	DP-DX22-CLBS	Clutch Bushing for 1" Shaft	1
7	DP-DX22-ENFP	Engine Fixing Plate	1
9	DP-DX-DSP	Driven Synchronous Pulley	1
10	DP-GH-DX0265	M8 x 25mm Countersunk screws for Fixing Plate	5
13	DP-GH-DX0267	M8 x 30mm Socket Head Bolt	12
14	DP-DX22-ENGHW-K	Motor Mounting Hardware Kit	1
18	DP-BEAR-6208-LOWER	Lower Bearing Base Assembly 6208	1
19	DP-DX22-INTS	Intermediate Shaft	1
21	DP-DX-SYBT	Synchronous Belt	1
23	DP-DX22-PSP	Pulley Spacer	1
24	DP-DX22-TRANS-CASE	Transmission Casing	1
26	DP-DX22-TOTC	Top Transmission cover	1
27	DP-GH-DX0272	M8 x 20mm Countersunk Bolts for Front Transmission Cover	4
28	DP-DX22-TRSC	Side Covers for Transmission	2
29	DP-GH-DX0273	M6 x 10mm Rounded Socket Head Bolts for side covers	8
32	DP-GH-DX0276	3/8"-16 Hex Head Bolts for Engine Mounting	4
34	DP-DX22-TUNN	Tensioning Post	1
35	DP-GH-DX0278	M8 x 20mm Socket Head Screw	4
37	DP-DX22-LWP-K	Lower Pulley Assembly Kit	1
41	DP-DX22-CLMS	Clutch Mounting Spacer	1
42	DP-GH-DX0264	M10 x 100mm Socket Head Tensioning Bolt	1
43	DP-GH-DX0279	M10 Flat Washer for Lower Tensioning Bolt	1
44	DP-GH-EMCAR-K	Anti-Rotation Pin Assembly Kit	1
NP	DP-BEAR-6208	Intermediate Shaft Bearing	2
NP	DP-GH-DX0266	Retaining Ring	2
NP	DP-KEY-10X8X22	Machine Key 10x8x22	1
NP	DP-DX-DSP-LF	Synchronous Pulley Locking Flange	1
NP	DP-GH-DX0271	M8 x 25mm Socket Head Screws	4
NP	DP-DX22-FRTC	Front Transmission Cover	1



# LED BRACKET ASSEMBLY

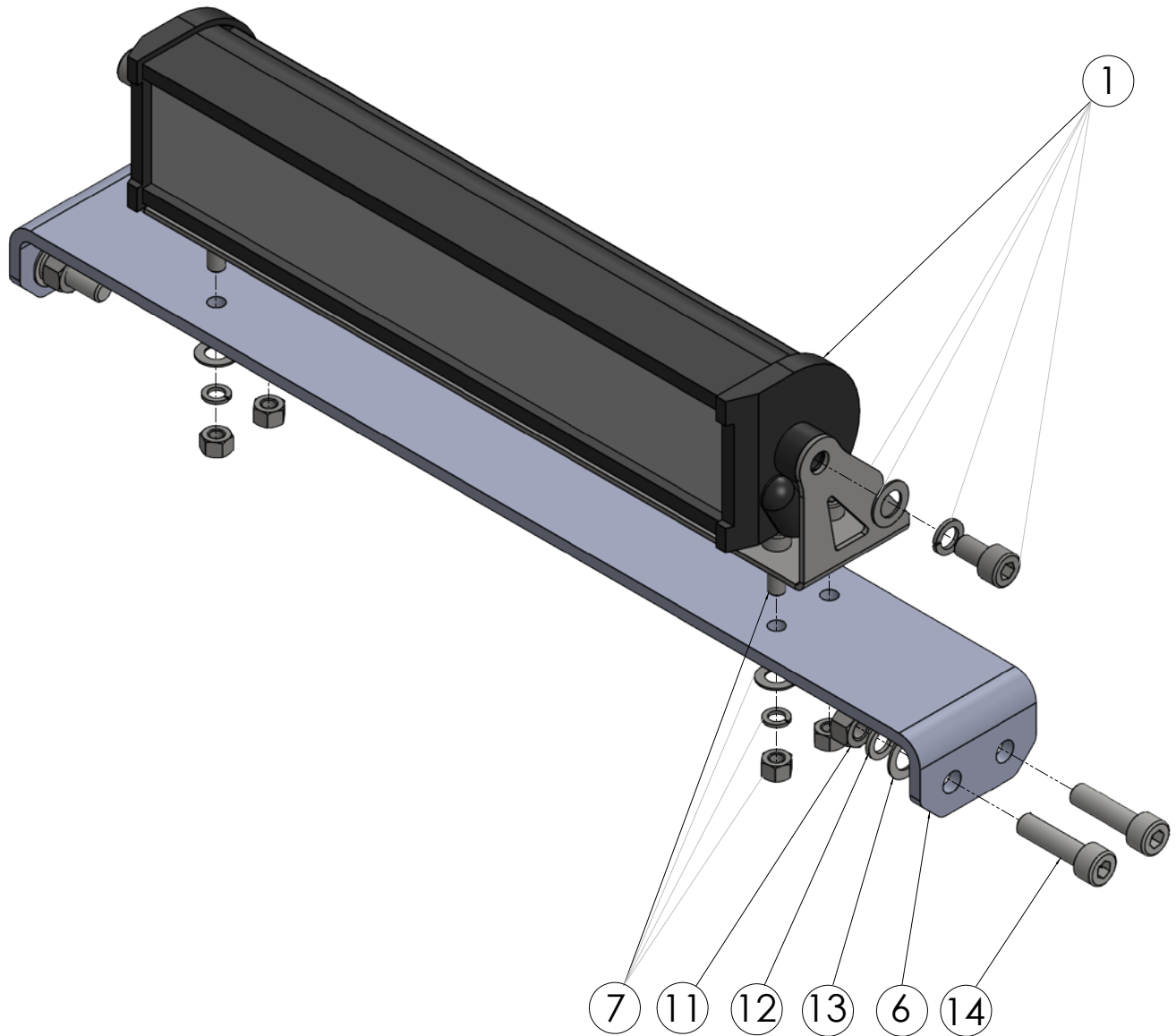

ITEM NO.	PART NUMBER	DESCRIPTION	QTY.
1	DP-DX22-LLED-K	LED Work Light Kit	1
6	DP-DX22-RFPT	Reinforcement Plate	1
7	DP-DX22-LLED-HW	LED Hardware Kit	1
11	DP-GH-DX0124	M8 Nut	4
12	DP-GH-DX0269	M8 Split Washer	4
13	DP-GH-DX0270	M8 Washer	4
14	DP-GH-DX0267	M8 x 30mm Socket Head Bolt	4

# TANK BRACKET ASSEMBLY

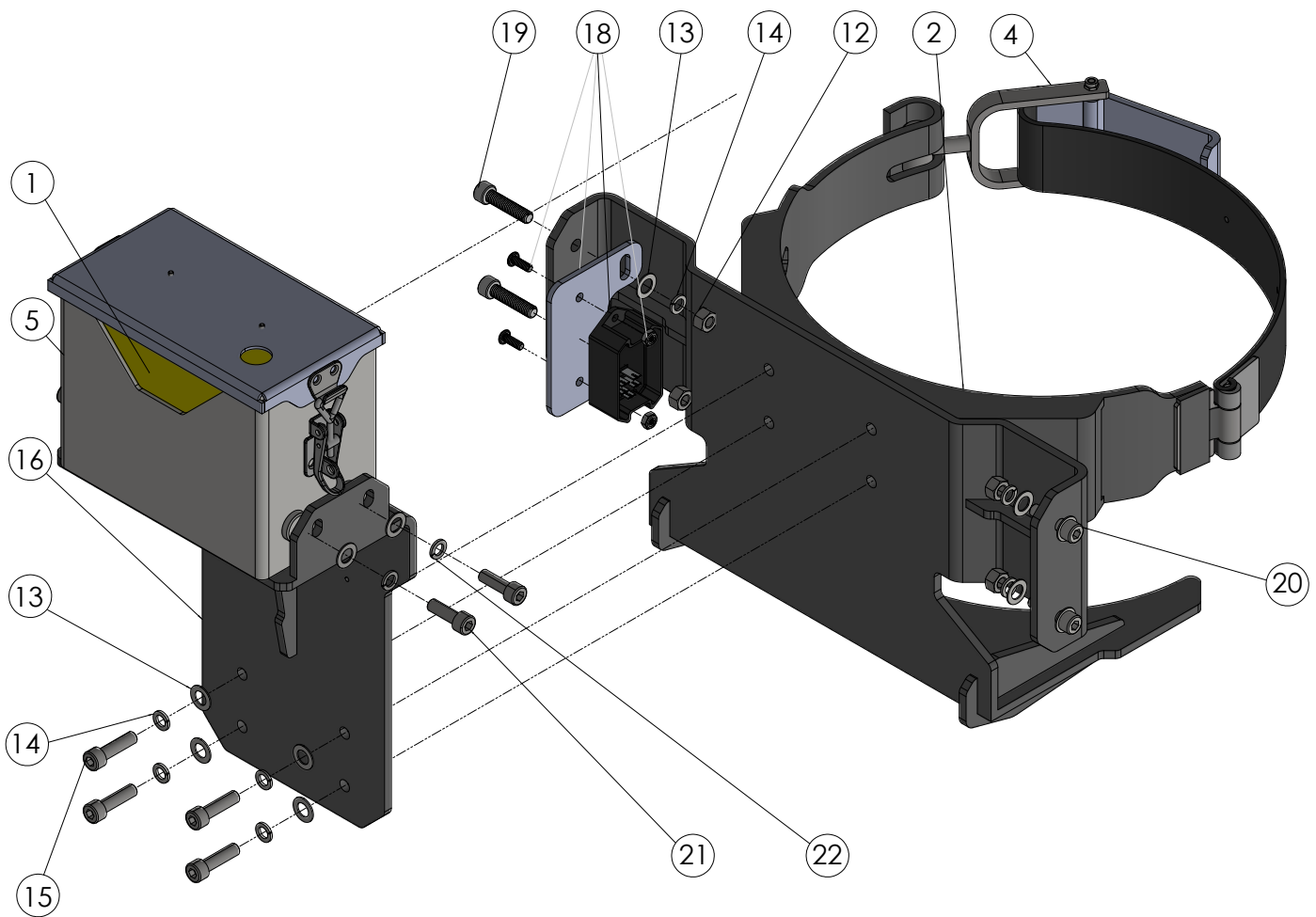

ITEM NO.	PART NUMBER	DESCRIPTION	QTY.
1	W4359	Motobatt	1
2	DP-DX22-PRTL	Propane Tank Loop	1
4	DP-GH-D009	Propane Tank Clasp	1
5	DP-DX22-BATBX	Battery Box	1
12	DP-GH-DX0124	M8 Nut	4
13	DP-GH-DX0270	M8 Washer	16
14	DP-GH-DX0269	M8 Split Washer	8
15	DP-GH-DX0267	M8 x 30mm Socket Head Bolt	4
16	DP-DX22-BBM	Battery Box Mount	1
18	DP-DX22-SSK	Soft Start Kit	1
19	DP-GH-DX0130	M8 x 35mm Socket Head Bolt	2
20	DP-GH-DX0267	M8 x 30mm Socket Head Bolt	2
21	DP-GH-DX0131	M8 x 25mm Socket Head Bolt	4
22	DP-GH-A526	M8 Split Washer	2

# LOWER FRAME ASSEMBLY

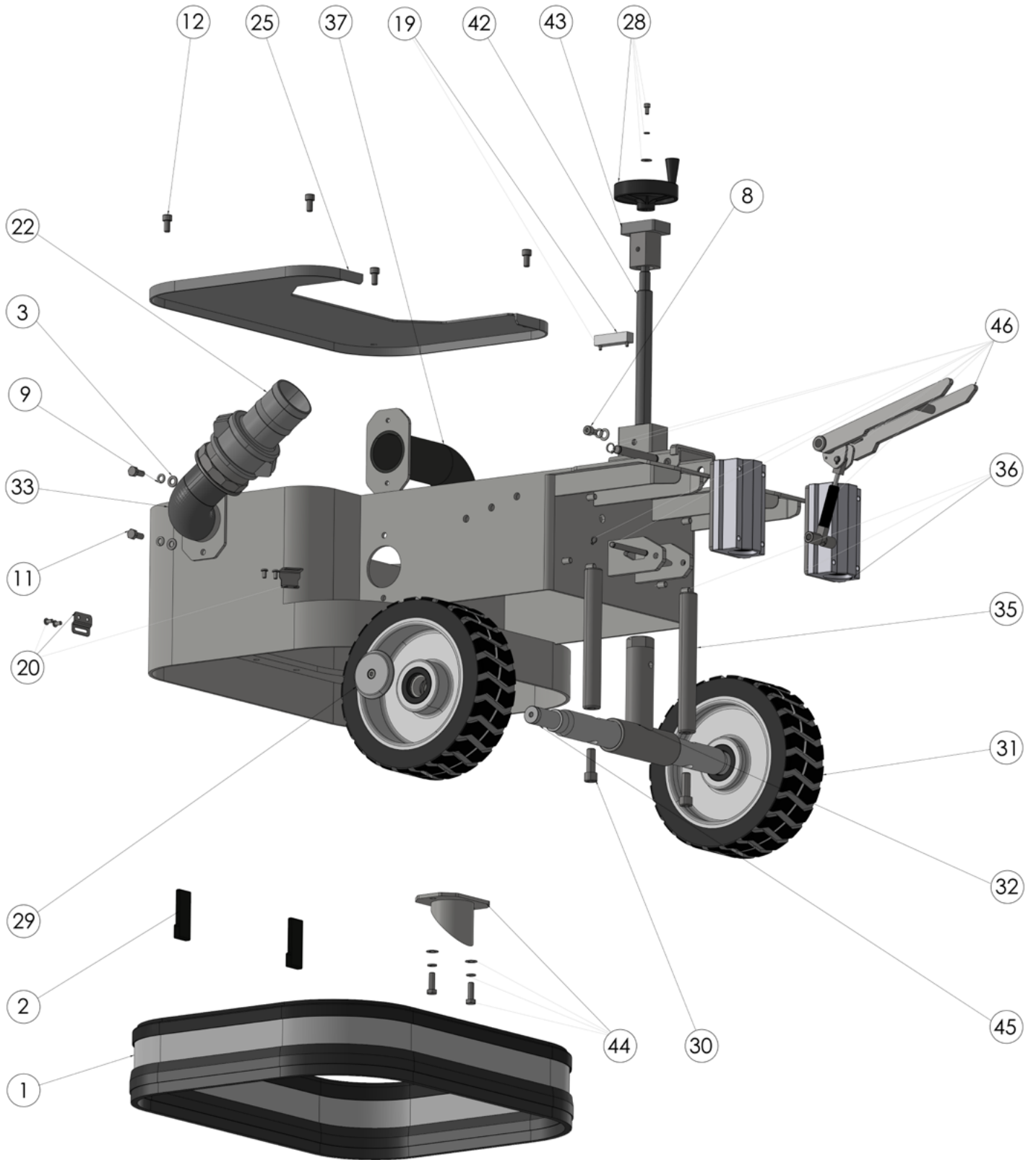

## LOWER FRAME ASSEMBLY

ITEM NO.	PART NUMBER	DESCRIPTION	QTY.
1	DP-DX22-MTDC	Metal Dust Cover	1
2	DP-GH-DX0167	Hook and Loop Straps	2
3	DP-GH-DX0270	M8 Flat Washer	2
8	DP-GH-DX0156	M8 x 12mm Socket Head Bolt	2
9	DP-GH-DX0269	M8 Split Washer	2
11	DP-GH-DX0278	M8 x 20mm Socket Head Screw	2
12	DP-GH-DX0158	M8 x 16mm Socket Head Bolt	4
19	DP-DX22-LEVB-K	Leveling Sight Glass Kit	1
20	DP-DX22-STRAP-BRKT-K	Dust Shroud Bracket Kit	1
22	DP-DX-FCL25	Female Camlock	1
25	DP-DX22-GBTC	Gearbox Top Cover	1
28	DP-DX22-LTHD-K	Height Adjustment Wheel Kit	1
29	DP-DX-WCAP	Wheel Cap	2
30	DP-GH-DX0166	M12 x 30mm Hex Socket Bolt	2
31	DP-DX-WHEEL	Wheel	2
32	DP-DX22-LVSL	Leveling Sleeve	1
33	DP-DX22-ODT	Outer Dust Tubing	1
35	DP-GH-DX0169	Leveling Shaft	2
36	DP-DX22-LSB-K	Linear Sleeve Bearing Kit	1
37	DP-DX22-MDT	Middle Dust Tubing	1
42	DP-GH-DX0173	Leveling Screw	1
43	DP-GH-DX0174	Leveling Collar	1
44	DP-DX22-LDT-K	Lower Dust Tubing Kit	1
45	DP-DX22-AXLE	Wheel Axle	1
46	DP-GH-DX0170-K	Kick Stand Assembly Kit	1
NP	DP-DX-MCL25	Male Camlock	1
NP	DP-DX22-FGBA	Full Gearbox Assembly	1

# HANDLE ASSEMBLY

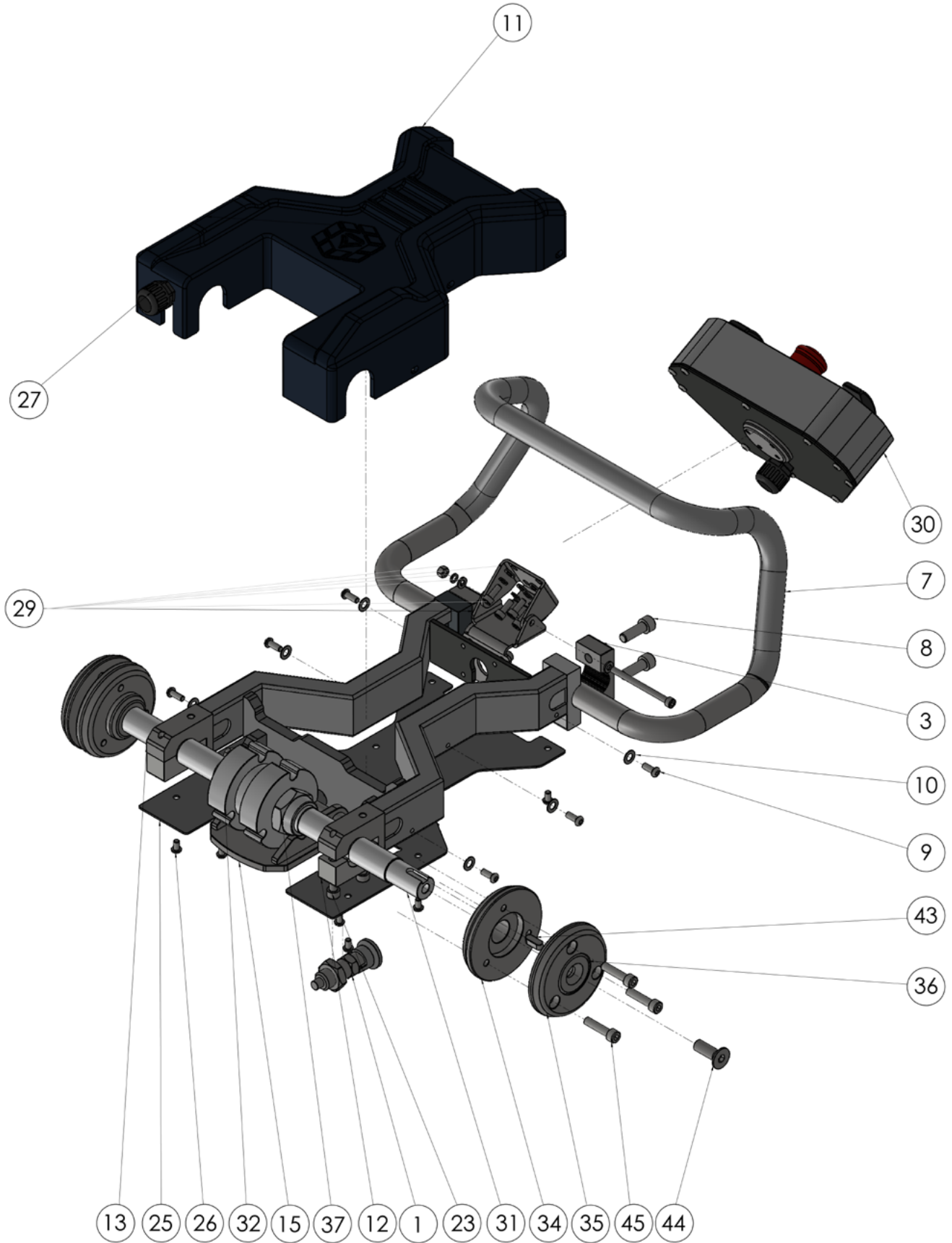

## HANDLE ASSEMBLY

ITEM NO.	PART NUMBER	DESCRIPTION	QTY.
1	DP-DX-IDP20	Index Pin	1
3	DP-DX-HBCL	Handle Bar Clamp	2
7	DP-DX22-HNDL	DX22 Handle Bar	1
8	DP-GH-DX0288	M10 x 30 Socket Head Bolts	4
9	DP-GH-DX0289	M6 x 16 Button Head Hex Bolt	6
10	DP-GH-DX0284	M6 Washer	6
11	DP-DX22-HNDC	Handle Cover	1
12	DP-DX-LSCL	Lower Connection Shaft Clamp	2
13	DP-DX22-OHFR	Operating Handle Frame	2
15	DP-DX-AJHD	Adjustment Handle	1
23	DP-GH-DX0130	M8 x 35 Socket Head Bolt	4
25	DP-DX22-HBPL	Housing Bottom Plate	1
26	DP-GH-DX0290	M6 x 10 Button Head Hex Bolt	10
27	DP-GH-DX0297	Strain Relief	1
29	DP-DX22-CBB-K	Control Box Assembly Kit	1
30	DP-DX-CBOX	Control Box	1
31	DP-DX-HCST	Handle Connection Shaft	1
32	DP-DX-HGAB	Handle Gear Adjustment Base	1
34	DP-DX-HCSC	Handle Connection Shaft Collar	2
35	DP-DX-SPP	Shaft Positioning Plate	2
36	DP-DX-HCSP	Handle Connection Shaft Plug	2
37	DP-DX-ABPN	Adjustment Base Positioning Nut	2
43	DP-KEY-8X7X22	Key 8x7x22	2
44	DP-GH-DX0296	M12 x 35 Countersunk Bolt	2
45	DP-GH-DX0130	M8 x 35 Socket Head Bolt	6
NP	DP-DX-SRSS	Spring Positioning Shaft Bushing	2
NP	DP-DX-SRPP	Spring (Left + Right Symmetry)	2
NP	DP-DX-SRST	Internal Spring Shaft	1
NP	DP-GH-DX0278	M8 x 20mm Socket Head Screw	2
NP	DP-GH-DX0270	M8 Washer	2

# CONTROL PANEL ASSEMBLY

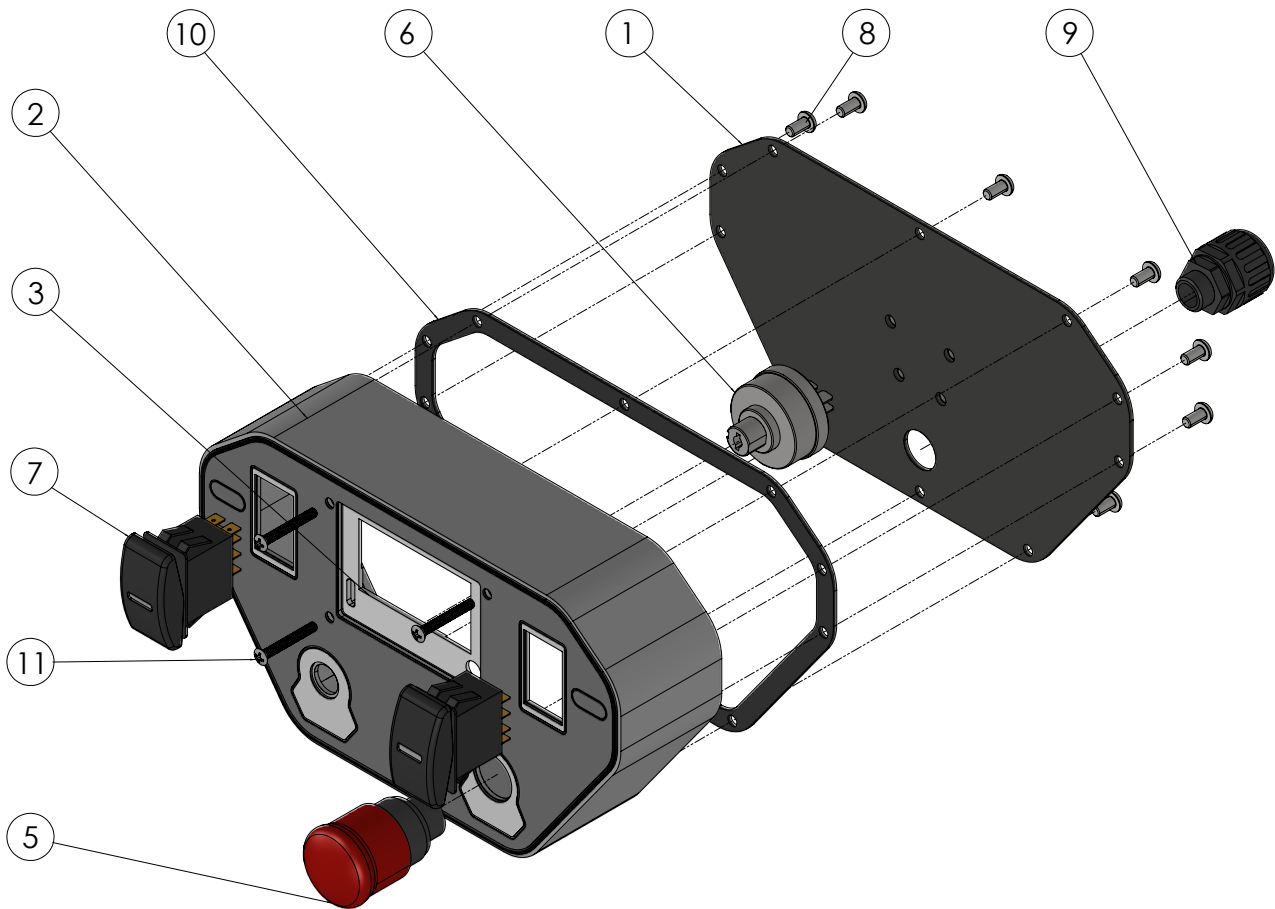

ITEM NO.	PART NUMBER	DESCRIPTION	QTY.
1	DP-DX-CPBP	Control Panel Back Plate	1
2	DP-DX-CPEN	Control Panel Enclosure	1
3	DP-EMS-H	SAM Unit	1
5	DP-DX-ESSW	E-Stop Switch	1
6	DP-DX-ISWK	Ignition/Key Switch	1
7	DP-DX-2PSW	2-Position Switch (Clutch & LED Switch)	2
8	DP-GH-DX0155	M5 x 10 Button Head Hex Bolt	10
9	DP-GH-DX0297	Strain Relief	1
10	DP-DX-CPGS	Control Panel Gasket	1
11	DP-GH-832SW	Sam Unit Screws	4

# GEAR BOX

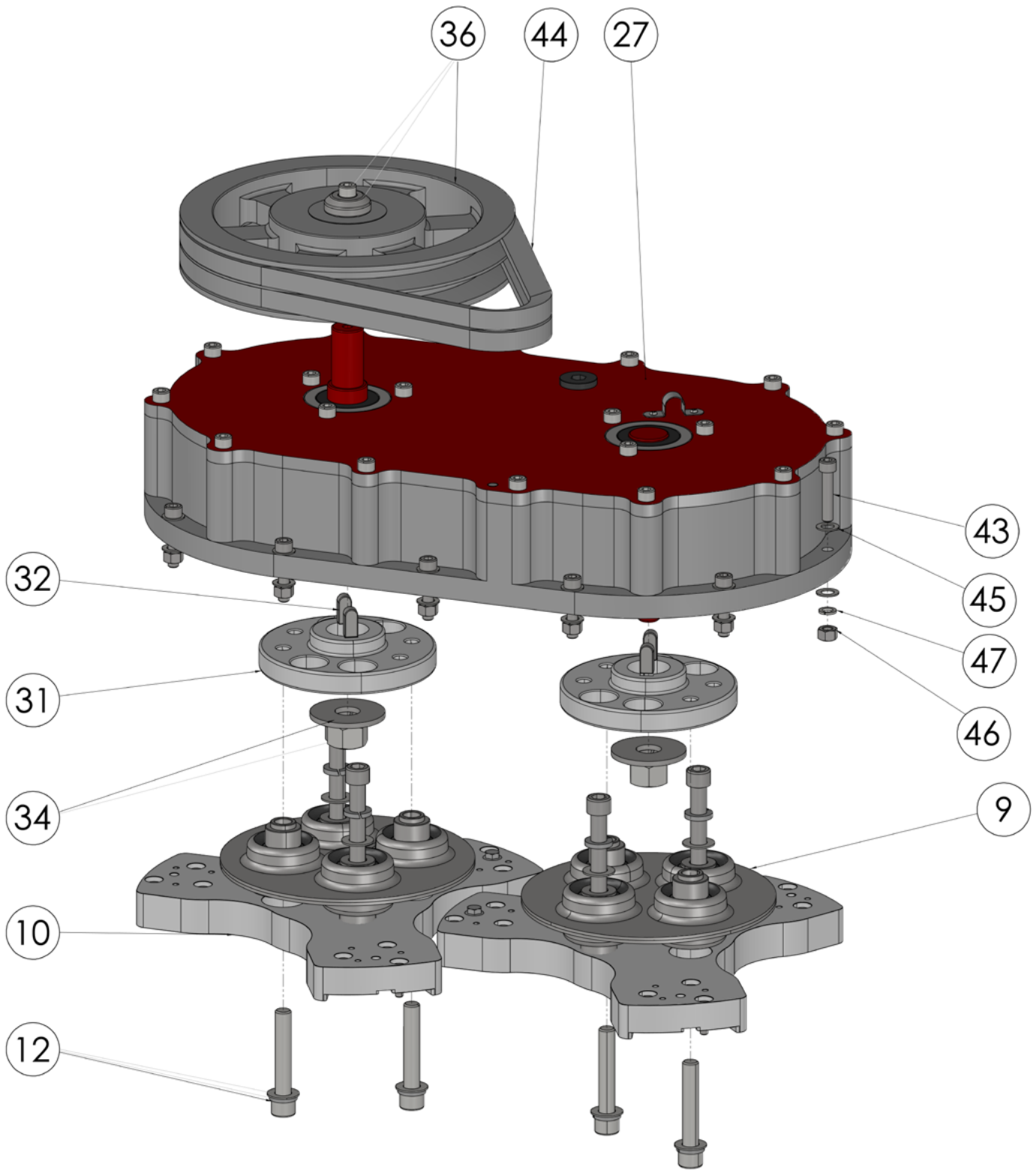



## GEAR BOX

ITEM NO.	PART NUMBER	DESCRIPTION	QTY.
9	DP-GH-FLCO	Flex Coupler	2
10	DP-GH-GRPL	DX22 Aluminum Tool Plate	2
12	DP-DX-TPHW-KIT	Tool Plate Hardware Kit	1
27	DP-DX22-FGBA	Full Gearbox Assembly	1
31	DP-DX-GRCB	Claw Base	2
32	DP-KEY-10X8X22	Claw Base Shear Key 10X8X22	4
34	DP-GH-DX0121-K	Claw Base Hardware Kit	1
36	DP-DX22-BTPY-250-K	Lower Belt Pulley Kit	1
43	DP-GH-DX0122	Hex Socket Bolt M8X40	12
44	DP-GH-BX34	Cogged V-Belt	2
45	DP-GH-DX0270	M8 Washer	24
46	DP-GH-DX0124	M8 NUT	12
47	DP-GH-DX0269	M8 SPLIT WASHER	12

# WIRING DIAGRAM

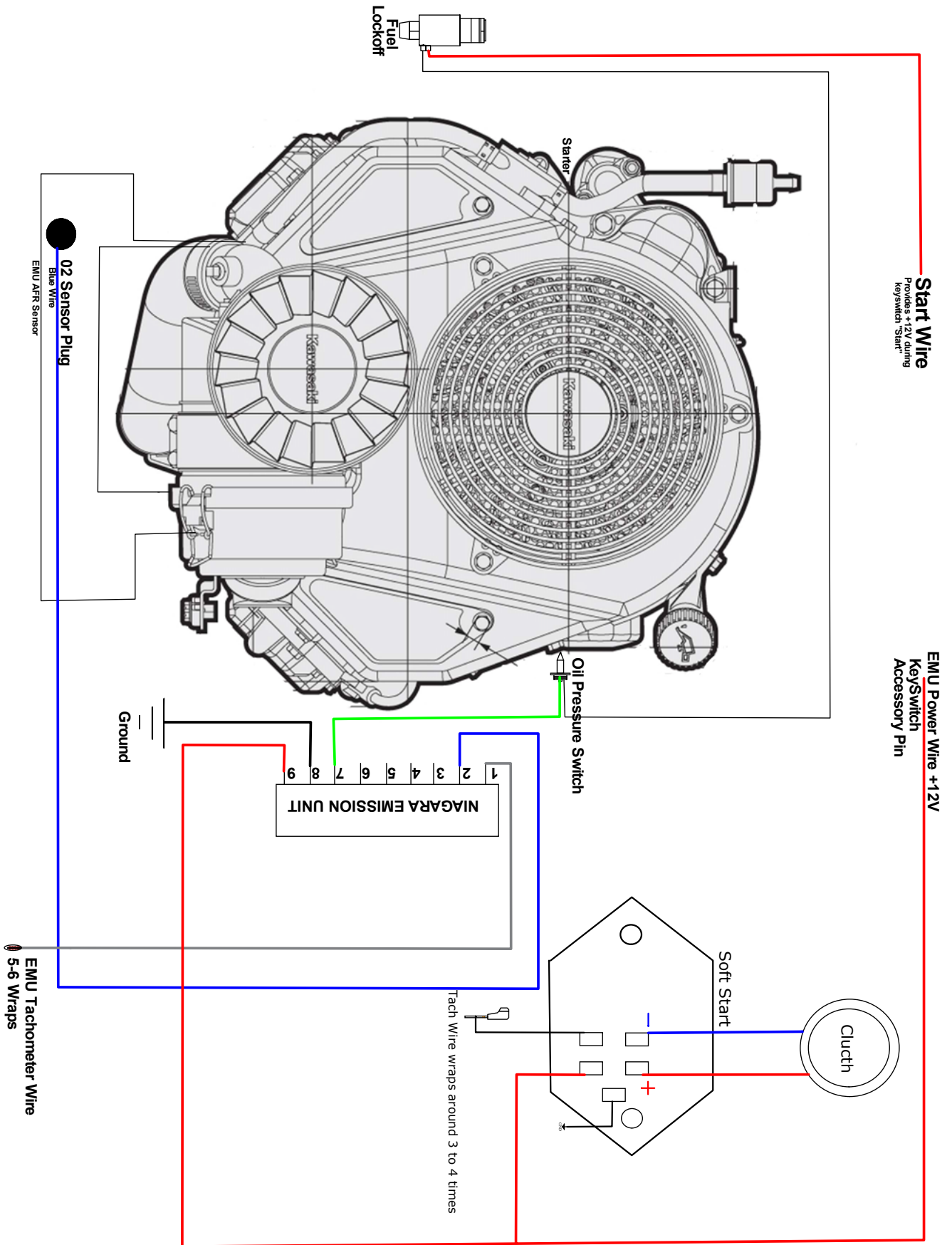



**Diamapro<sup>®</sup>**  

---

**SYSTEMS**

Diamapro<sup>®</sup> Systems  
3343 Peachtree Road NE  
Suite 145 #24  
Atlanta, GA 30326  
470-977-2323