



DiamaPro[®]
SYSTEMS

OWNER'S MANUAL

DX26-P

ROTARY FLOOR GRINDER



OPERATION & MAINTENANCE MANUAL

SAVE THESE INSTRUCTIONS FOR FUTURE REFERENCE



WARNING
Cancer and Reproductive Harm
www.P65Warnings.ca.gov

IMPORTANT WARNINGS AND SAFETY INSTRUCTIONS

WARNING

CALIFORNIA PROP 65 WARNING

Use of this product can cause exposure to materials known to the State of California to cause cancer and/or birth defects or other reproductive harm.
www.P65Warnings.ca.gov

WARNING

The engine exhaust from this product contains chemicals known to the State of California to cause cancer, birth defects or other reproductive harm.

WARNING

This product contains one or more chemicals known to the State of California to cause cancer, birth defects or other reproductive harm.

WARNING

CARBON MONOXIDE WARNING

This machine contains a fossil fuel burning engine.
Use of this product can cause exposure to Carbon Monoxide.

DANGER



Carbon Monoxide (CO) is a colorless, odorless, invisible gas. Exposure to high levels will cause headaches, dizziness, and/or death. Obey all PPE requirements including, but not limited to Personal CO Monitoring Device(s) at all times and if high levels of CO are present, vacate the area immediately.

DANGER



All internal combustion engines produce CO.
Only use this machine in work areas that are adequately ventilated.
Failure to do so will result in injury or death.



WARRANTY REGISTRATION CARD

Form must be completed and submitted within 30 days from the date of purchase.

Customer Information

First and Last Name

Company Name

Address

City

State

Zip Code

Phone Number

Email

Machine Information

Machine Type

Machine Model

Serial #

Purchase Date (dd/mm/yy)

Diamapro® Systems
3343 Peachtree Road NE
Suite 145 #24
Atlanta, GA 30326

INTRODUCTION

Thank you for purchasing a DIAMAPRO® SYSTEMS product. This manual provides information and procedures to safely operate and maintain the DiamoPro® DX26-P. For your own safety and protection from injury, carefully read, understand, and observe the safety instructions described in this manual. Keep this manual or a copy of it with the machine. If you lose this manual or need an additional copy, please download from our website or contact DiamoPro® Systems. This machine is designed and built with user safety in mind; however, it can present hazards if improperly operated and serviced. Please follow the operating instructions carefully. If there are any questions regarding operating or servicing of this machine, please contact DiamoPro® Systems.

Disclaimer: DiamoPro® Systems and its affiliates take no responsibility for any damage, injury or death resulting from the incorrect or unsafe use of this product. The use of this product should be undertaken by competent people only. It is the operator's responsibility to ensure that the following safety procedures are followed. If you are unsure, **DO NOT OPERATE** this product.

1. GENERAL INFORMATION

1.1 SAFETY CLASSIFICATIONS

These classifications are here to inform and alert you to potential hazards or situations to you, job site bystanders, or your equipment. Take the time to understand these classifications and pay close attention when you see these words and icons in the book or on the machine. Always carefully read and follow all instructions. **YOUR SAFETY IS AT STAKE.**

1.1.1 Dangers

DANGER

A **DANGER** indicates a hazardous situation that, if not avoided, will result in death or serious injury.

1.1.2 Warnings

WARNING

A **WARNING** indicates a hazardous situation in which serious injury or death could result if the warning is ignored.

1.1.3 Cautions

CAUTION

A **CAUTION** indicates a hazardous situation in which injury, damage to your machine, or both could result if the caution is ignored.

1.1.4 Notices

NOTICE

A **NOTICE** indicates information that is important but not hazard related.

1.1.5 Helpful Tips

Helpful Tip!

A **Helpful Tip** indicates items that may be helpful to the operator during use of this machine.

1.2 SAFETY SIGNS

It is necessary to recognize the meaning of the signs present on the machine and keep their message readable. In case of damage replace them immediately, preventing the use of the machine. The DiamoPro® DX26-P bears the following safety signs (pictograms).

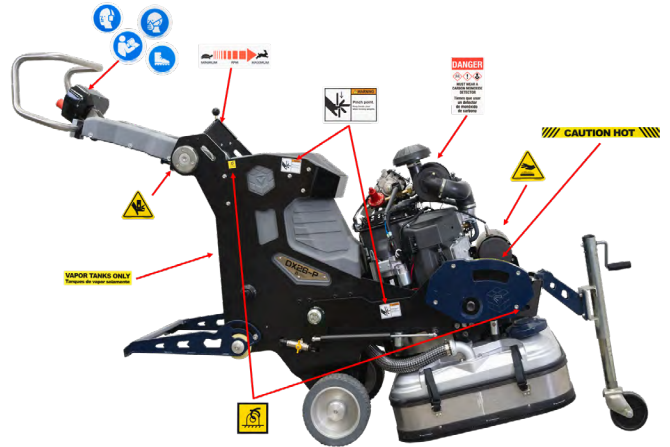

NOTICE SIGN "Must Read the Manual"	
INSTRUCTION SIGN "Throttle Direction"	
INSTRUCTION SIGN "Tie Down Point"	
HAZARD SIGN "Warning: Pinch Point"	
HAZARD SIGN "Danger: Carbon Monoxide"	
HAZARD SIGN "Warning: Crush Hazard"	
HAZARD SIGN "Warning: Hot Surface"	
HAZARD SIGN "Caution: Hot"	
NOTICE SIGN "Mandatory Use of Ear Protection"	
NOTICE SIGN "Mandatory Use of Safety Shoes"	
NOTICE SIGN "Mandatory Use of Appropriate Respirator"	

NOTICE

Do not remove, damage or modify the pictograms on the machine. Before each work shift, check their presence and good condition. In case of deterioration, replace them, preventing the use of the machine until the replacement has taken place.

1.3 SPARE PART ORDERS

The order of replacement parts must clearly state the data necessary for their identification and the data shown on the machine identification plate. Ex.:

- Machine model
- Type
- Serial number
- Year of construction
- Description
- Requested quantity
- Shipping method
- Address, telephone number and name

For any additional information please contact the manufacturer.

2. OPERATING ENVIRONMENT SAFETY

2.1 OPERATING ENVIRONMENT

The DiamaPro® DX26-P can be operated within the temperature range of 41°F to 86°F (5°C to 30°C). It's crucial to avoid using the machine during rainy or snowy weather conditions. Only use this machine in work areas that are adequately ventilated.

2.2 PROTECTION DEVICES

The DiamaPro® DX26-P is equipped with multiple safety mechanisms, including: a protective skirt and a hood that shields the tool plates, dust port with included cam locks for attachment of an appropriate HEPA-Filter dust collector(s), & an emissions monitoring device (See Section 3). These device(s) and/or system(s) safeguard the operator and any other individuals from potential harm. It is imperative not to remove them. Instead, prior to utilizing the machinery, ensure that all safety devices are appropriately installed and operational

2.3 USAGE SAFETY

The DiamaPro® Systems DX26-P is intended to minimize associated hazards related to its operation. Nonetheless, it is not entirely feasible to eliminate the possibility of accidents with the machine. Inexperienced or untrained operators may cause residual risks associated with but not limited to:

- Positional hazards due to improper operator posture.
- Entanglement hazards arising from the use of unsuitable work attire.
- Training hazards caused by insufficient operational training.

2.4 SAFETY MEASURES FOR PROPANE

WARNING

Always check all propane fittings are secure and no leaks are present. If leaks are present do not operate. Failure to do so may result in fire or explosion that could cause serious injury or death.

Propane or Liquefied petroleum gas (LPG) is a flammable gas with vapors that are denser than air. Like gasoline, improper handling of propane can lead to explosions. To aid in detecting leaks, propane may be mixed with an odorant that has a distinctive smell, detectable at low concentrations. When working with propane, it is essential to be aware and take necessary safety precautions. Lack of awareness could result in needless hazards. The two most significant dangers associated with propane-powered floor care machines are:

- Carbon Monoxide Poisoning:
 - Carbon monoxide poisoning is the most reported incident associated with propane-powered floor care machines, caused by excessive exhaust emissions. The symptoms include headaches, dizziness, and nausea. Engines with inadequate preventive maintenance practices, particularly those with unclean air filters and machines operated in enclosed spaces without sufficient ventilation, are a significant cause.



The use of substandard, inexpensive machines without emissions control technology and improperly adjusted carburetion could also contribute to the problem.

- Overfilled Fuel Cylinders:
 - Overfilling a propane cylinder (over 80% full) can increase risks such as (but not limited to) ruptures or leaks which can cause accidents, environmental hazards, and damage to property. This practice is hazardous, imprudent, and avoidable.
- Fire Precautions
 - Be mindful of the potential risks of fire when working with propane and take standard fire-safety measures.
 - There is a likelihood of fire resulting from leakage or venting of LPG vapor from fuel cylinders or carburetion equipment.
- Explosion Precautions
 - Be mindful of the potential risks of explosion when working with propane and take standard fire-safety measures.
 - Concentration or confinement of LPG vapor in a restricted or small space may cause ignition or explosion.
 - Propane may also experience a BLEVE: Boiling Liquid Expanding Vapor Explosion.

CAUTION



Respirable crystalline silica causes damage to lungs and may cause cancer. Always wear respiratory protection during exposure. Always use appropriate dust control equipment to keep dust within OSHA and local regulation limits.

2.5 SAFETY MEASURES FOR DUST

Cutting, especially when DRY cutting, generates dust that comes from the material being cut, which frequently contains silica. **When dry-cutting, be sure to use an appropriate sized HEPA filtered dust collector.**

Silica is a basic component of sand, quartz, concrete, brick clay, granite and numerous other minerals and rocks. Exposure to excessive amount of such dust can cause the following symptoms according to NTP* and IARC*:

- Respiratory diseases (affecting your ability to breath), including chronic bronchitis, silicosis, and pulmonary fibrosis from exposure to silica. These diseases may be fatal.
- Cancer
- Skin irritation and rash

*National Toxicology Program, International Agency for Research on Cancer

Take precautionary steps:

- Avoid inhalation of and skin contact with dust, mist, and fumes.
- Wet cut when feasible, to minimize dust.
- Wear and ensure that all bystanders wear appropriate respiratory protection such as dust masks designed to filter out microscopic particles (See OSHA 29 CFR Part 1910.1200).

2.6 SAFETY MEASURES FOR CARBON MONOXIDE

DANGER



Carbon Monoxide (CO) is a colorless, odorless, invisible gas. Exposure to high levels will cause headaches, dizziness, and/or death. Obey all PPE requirements including, but not limited to Personal CO Monitoring Device(s) at all times and if high levels of CO are present, vacate the area immediately.

DANGER



All internal combustion engines produce CO. Only use this machine in work areas that are adequately ventilated. Failure to do so will result in injury or death.

Carbon Monoxide (CO) is a colorless, odorless, invisible gas formed during the incomplete combustion of carbon containing fuels such as (but not limited to) gasoline or propane. Exposure to high levels of Carbon Monoxide can cause the following symptoms:

- Nausea
- Headaches
- Fatigue
- Dizziness
- Drowsiness
- Unconsciousness
- Death

The Occupational Health & Safety Administration (OSHA) has implemented an 8-hour time-weighted average (TWA) limit of 50 Parts per Million (PPM) of Carbon Monoxide in ambient air. All occupants must leave the enclosed area if the CO concentration in said space exceeds a ceiling of 100 PPM (OSHA 1917.24(a)).

This machine is equipped with a safety device to aid in the safety of the operator. This device is NOT a substitute for a certified personal CO Monitoring device, proper area ventilation, and all other required safety devices and procedures.

2.7 EMISSIONS

All propane-powered floor care machines generate emissions. While most are innocuous, some can be hazardous, even fatal. Carbon monoxide (CO) presents the most significant danger. See the Safety Measures for Carbon Monoxide section in the Operating Environment Safety section of the manual.

2.8 AGENCIES AND REGULATIONS

All propane-powered floor care machines generate emissions. While most are innocuous, some can be hazardous, even fatal. Carbon monoxide (CO) presents the most significant danger. See the Safety Measures for Carbon Monoxide section in the Operating Environment Safety section of the manual.

- National Fire Protection Agency (NFPA):
 - To operate a propane-powered floor care machine safely, it is necessary to adhere to specific safety regulations. The NFPA is responsible for ensuring safe propane use and storage, and their Standard for Storage and Handling of LP Gas should be consulted for guidance. Copies of this publication can be obtained by contacting the NFPA in Quincy, MA at 1-800-334-3555.
 - One important regulation set forth by the NFPA #58 is that all personnel who handle propane gas must be properly trained in its safe handling and operation procedures and carry a certification from their employer or training supervisor attesting to this fact. While this requirement primarily applies to individuals who fill and transport liquid propane gas, DiamoPro® Systems recommends that operators of propane-powered floor care machines in public areas also receive proper training and certification. Although NFPA 58 8-4.5 permits the use of propane-powered floor care equipment in buildings frequented by the public, including when they are occupied, DiamoPro® Systems suggests that these machines be used when occupancy is minimal.
- California Air Resource Board (CARB) & Environmental Protection Agency (EPA):
 - While CARB and EPA establish limits for propane-powered engines used outdoors, it is important to note that approval from CARB/EPA does not indicate that the engine is safe for indoor use.
- Canadian Gas Association (CGA):
 - A limit of 1500 ppm CO in exhaust flow has been established by the CGA.
- Occupational Health and Safety Administration (OSHA):
 - When it comes to propane-powered machines, OSHA has implemented an 8-hour time-weighted average (TWA) limit of 50 Parts per Million (PPM) of Carbon Monoxide in ambient air. All occupants must leave the enclosed area if the CO concentration in said space exceeds a ceiling of 100 PPM (OSHA 1917.24(a)).
- Department of Transportation (DOT):
 - Regulations have been set forth by the DOT regarding the safety of fuel cylinders, including those utilized on propane-powered floor care machines.

- Local Agencies:
 - Before granting approval for the use of certain equipment, local law enforcement agencies such as the Fire Marshall may rely on independent testing laboratories like UL and CGA. These labs conduct extensive testing of equipment and only issue their approval after a rigorous evaluation process. While not mandatory for all law enforcement agencies, the stamp of approval from these organizations serves as an additional assurance for operators that they are working with and around safe equipment.
 - Additional rules & regulations may differ based on location. Always check with the appropriate governing body before operating machinery.

2.9 PERSONAL PROTECTIVE EQUIPMENT

When operating this machine, it is important to:

- Wear safety shoes always.
- Wear certified hearing protection to safeguard your hearing.
- Wear a certified respirator for the environment.
- Ensure that all personnel in the work area wear safety glasses with side shields.
- Wear safety gloves when changing tools.
- Dress appropriately for the work environment.
- Use certified personal Carbon Monoxide monitors.

2.10 TESTING

Numerous tools are available in the market for detecting toxic gases. However, only the ones specifically designed for detecting carbon monoxide resulting from combustion engines are deemed suitable for testing exhaust emissions from floor machines powered by propane. Certain instruments are meant for detecting "ambient air" and may get damaged if utilized for taking readings in the muffler or tailpipe. Hence, it is crucial to select the appropriate instrument to fulfill the testing requirements. In general, instruments that can detect readings in ppm (parts per million) ranging from 0 to 1000 are sufficient for examining ambient air, i.e., the air in the breathing zone of the operator. On the other hand, devices capable of testing carbon monoxide in the exhaust should be certified by the manufacturer for that purpose and should be able to read from 0 to at least 2000 ppm.

Some examples of instruments and systems for these purposes may include:

- Ambient Air Monitors
- Engine Exhaust Analyzers
- Gas Data Loggers

All instruments used for testing must be calibrated at the intervals recommended by the manufacturer. The test results must include the monitor's model number and date of calibration.

3. EMISSIONS MONITORING UNIT

DiamaPro® DX26-P is equipped with an Emissions monitoring unit. This device is used to give the user information on the running conditions of the machine during use.

Disclaimer: All values and specifications are for a well-maintained, working machine. The user must always wear proper PPE, including but not limited to personal monitoring device(s).

3.1 EMISSION MONITORING UNIT IMPORTANT NOTES

NOTICE

This EMISSION MONITORING UNIT is not a substitute for:

- A personal monitoring device
- Proper job site safety practices
- All local regulations

NOTICE

Read all instructions related to the emissions monitoring unit.
Be sure to understand all safety and environmental practices before use.

NOTICE

This emission monitoring unit must be replaced after 5 years from installation.
Failure to do so may result in a decrease in effectiveness of the monitor.

NOTICE

TO Clean the EMISSION MONITORING UNIT, use a vacuum cleaner brush to vacuum around the openings on the monitor. The outside of the monitor may be wiped with a lint-free cloth slightly dampened with water only.
DO NOT PRESSURE WASH THE UNIT!

3.2 EMISSION MONITORING UNIT WARNINGS & CAUTIONS

! DANGER



Carbon Monoxide (CO) is a colorless, odorless, invisible gas. Exposure to high levels will cause headaches, dizziness, and/or death. Obey all PPE requirements including, but not limited to Personal CO Monitoring Device(s) at all times and if high levels of CO are present, vacate the area immediately.

! DANGER



All internal combustion engines produce CO.
Only use this machine in work areas that are adequately ventilated. Failure to do so can result in injury or death.

! CAUTION

THIS MONITOR WILL ONLY INDICATE THE PRESENCE OF CARBON MONOXIDE GAS AT THE SENSOR. CARBON MONOXIDE GAS MAY BE PRESENT IN OTHER AREAS. THIS MONITOR IS DESIGNED TO DETECT CARBON MONOXIDE GAS FROM ANY SOURCE OF COMBUSTION. IT IS NOT DESIGNED TO DETECT SMOKE, FIRE OR ANY OTHER GAS.

! CAUTION

This monitor is designed to measure compliance with the U.S. Occupational Safety and Health Administration (OSHA) job site exposure limits, and does not comply with ACGIH, Cal/OSHA or NIOSH, which recommend lower exposure limits than OSHA. Consult with your local authority about the exposure limits permitted for your job site.

3.3 EMISSION MONITORING UNIT FEATURES & SPECIFICATIONS

CO MONITORING

Measures CO PPM (Parts per Million) every second, alarms above 35ppm. Automatically shuts engine down after 5 minutes above 35ppm, 4 minutes when above 200ppm, and 2 minutes when above 1200ppm.*

AFR MONITORING

Narrow band oxygen sensor produces voltage from 0v to 1v and indicates lean or rich fuel mixture.

SENSOR TYPE

Electrochemical with temperature and humidity sensors

OPERATING TEMPERATURE & HUMIDITY

0°F to 120°F @ 10% to 95% RH

SENSOR LIFE

5 years from time of installation

ELECTRICAL RATING

12 Volts

NOTICE

This SAM Safe Air Monitor has been specifically designed and programmed for use with DiamaPro equipment. Any modifications to this unit or use of any other unauthorized emission monitoring units will void warranty and may not function properly.

***Disclaimer:** All values and specifications are for a well-maintained, working machine.

3.4 EMISSION MONITORING UNIT OPERATIONS

OPERATION: The SAM Safe Air Monitor is operational once the engine is started. The SAM will begin to monitor carbon monoxide levels every 1 second.

The SAM Safe Air Monitor is designed to remain on for a brief period when the ignition is turned off. DO NOT leave the key switch in the accessory position. This will prematurely drain the battery.

NOTICE

The SAM Safe Air Monitor will draw a small amount of voltage from the battery which may cause the battery to be drained if stored for long periods of time. It is always recommended to disconnect the battery when the machine is not in use.

HOME SCREEN: The HOME screen will display engine hours, rpms, and indicate that the CO and ENG AFR are OK. If the CO or ENG AFR is high, it will indicate alarm.



ALARM SCREENS: The ALARM screen will display Carbon Monoxide alarms and AFR alarms. To stop the engine, press STOP. The Engine will automatically shut down if alarms are ignored and conditions do not improve in allotted time.

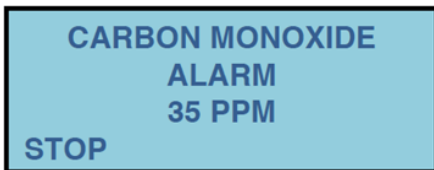

If alarm signal sounds:

Immediately increase ventilation and move the machine to a clean air environment. Monitor CO PPM and AFR in the new fresh air environment. CO PPM should drop below 35PPM and AFR should be less than 500mV. If the CO PPM and/or AFR remain above 35PPM and/or 500mV and the alarm continues to sound, discontinue use of the machine, and contact your supervisor. The machine will shut down automatically if the CO PPM limit remains exceeded. If the machine shuts down, move the machine to a clean air environment, restart machine and continue operation.

3.5 LIMITATIONS OF EMISSION MONITORING UNITS

NOTICE

This EMISSION MONITORING UNIT is not a substitute for:

- A personal monitoring device
- Proper job site safety practices
- All local regulations

Carbon monoxide monitors respond to the presence of CO. They do not detect smoke. If the alarm does activate, follow instructions in the “If the alarm signal sounds”.

Carbon monoxide monitors are devices that can provide an early warning of the presence of CO. However, monitors have sensing limitations and may not always sound a warning in the presence of CO. Carbon monoxide monitors cannot sense CO that does not reach the sensor, and therefore CO monitors may not detect CO which is in another area of the building. Furthermore, the monitor may not alert someone who is in a different area than the monitor. The use of drugs and alcohol may impair one’s ability to hear the monitor.

3.6 DESCRIPTION OF AUDIBLE AND VISUAL SIGNALS

LCD READOUT	CONDITION	ALARM
AIR: OK	Indicates CO levels are below OSHA limits	If CO levels are above OSHA limits, displays HIGH CO, alarm will sound
ENGINE: OK	Indicates Engine Air Fuel Ratio is below 500mV indicating a low CO running condition and Battery Voltage is greater than 12 volts	If Air Fuel Ratio is Rich, displays RICH MIXTURE, alarm will sound. LOW VOLTAGE indicated battery voltage is below 12 volts, CHECK OIL indicates low/no oil pressure.
CO PPM:	Indicates the current CO parts per million	Alarm sounds above 35ppm. Automatically shuts engine down after 5 minutes above 35ppm, 4 minutes when above 200ppm, and 2 minutes when above 1200ppm.*
AFR:	Indicates whether the engine is running rich or lean. Below 500mV the engine is running lean, above 500mV the engine is running rich	Alarm when engine runs rich for continuous 2 minutes, engine shutdown at 5 minutes.
HRS:	Displays engine hours in tenths of an hour	
RPM:	Displays engine revolutions per minute	
BATT:	Indicates battery voltage. If voltage is below 10 volts, the display reads low voltage	

***Disclaimer:** All values and specifications are for a well-maintained, working machine.

4. MACHINE OPERATION

4.1 SAFETY INSTRUCTIONS

4.1.1 KNOW THE RULES & YOUR EQUIPMENT

Most job sites have rules governing equipment use & maintenance. Before starting at a new work location, check with the supervisor or safety coordinator. Ask about any rules or regulations you need to abide by. OSHA enforces federal laws within the United States that apply to the safe operation, application, & maintenance of equipment on job sites. It is the employer's responsibility to comply with these laws. Do not operate this machine unless you carefully read the operations and maintenance manual.

4.1.2 RECEIVE PROPER TRAINING

Do not operate this machine unless you have received operational and maintenance training from a DiamoPro® Systems representative or from an authorized distributor for DiamoPro® Systems.

4.1.3 WEAR A PERSONAL MONITORING DEVICE FOR CARBON MONOXIDE

The operator and those in the area must ALWAYS use an approved personal carbon monoxide device.

! DANGER



Carbon Monoxide (CO) is a colorless, odorless, invisible gas. Exposure to high levels will cause headaches, dizziness, and/or death. Obey all PPE requirements including, but not limited to Personal CO Monitoring Device(s) at all times and if high levels of CO are present, vacate the area immediately.

! DANGER



All internal combustion engines produce CO. Only use this machine in work areas that are adequately ventilated. Failure to do so can result in injury or death.

4.1.4 PROTECT YOUR FEET

Observe all applicable local, state, and federal safety regulations. Wear OSHA approved foot protection.

4.1.5 PROTECT YOUR EYES

Observe all applicable local, state, and federal safety regulations. Wear OSHA approved safety glasses.

4.1.6 PROTECT YOUR LUNGS

! CAUTION



Respirable crystalline silica causes damage to lungs and may cause cancer. Always wear respiratory protection during exposure. Always use appropriate dust control equipment to keep dust within OSHA and local regulation limits.

Breathable silica may be generated by use of this product. Silica can cause severe and permanent lung damage, cancer, and other serious diseases. Do not breathe the dust. Do not rely on your sight or smell to determine if dust is in the air. Silica may be in the air without a visible dust cloud. If air monitoring equipment for silica is not provided by your employer at your work site, you MUST wear appropriate respiratory protection when using or servicing the machine. Consult your employer and OSHA regarding the appropriate respiratory protection.

4.1.7 PROTECT YOUR EARS

Observe all applicable local, state, and federal safety regulations. Wear OSHA approved hearing protection.

4.1.8 DRESS PROPERLY

Do not wear loose clothing or jewelry that can be caught in moving parts. Wear protective hair covering to contain long hair. Keep hair away from motor air vent. Rubber gloves and non-skid footwear are recommended when working outdoors.

4.1.9 AVOID A DANGEROUS ENVIRONMENT

Do not expose the machine to rain. Do not use the machine in wet conditions. Keep the work area well lit. When working at an elevated location, pay attention to articles and people below.

4.1.10 BEWARE OF HIDDEN DANGERS IN CONCRETE

Rebar or utility lines may be buried in concrete. Disconnect the power from any utility lines. If these dangers are present and are not clearly indicated, clearly mark the area.

4.1.11 KEEP WORK AREA CLEAN - DO NOT RUN OVER ANYTHING

Loose debris could be thrown from cracks. Make sure the area to be cut is clear from people and any loose objects, nuts, bolts, etc. Never run over any loose objects.

4.1.12 KEEP CHILDREN AND VISITORS AWAY

Do not allow anyone to stand in line with the grinding path. Do not let children or visitors in contact with machine or extension cord. Keep children and visitors away from the work area.

4.1.13 AVOID FLAMMABLE LIQUIDS OR GASES

! WARNING

Never use machines in areas containing flammable, combustible, or explosive materials such as but not limited to lacquer, paint, benzene, thinner, gasoline, gases, and adhesive agents. Failure to do so may result in fire or explosion that could cause serious injury or death.

Diamond Tooling produces heat and sparks during operation. Never use machines in dangerous sites containing flammable, combustible, or explosive materials such as lacquer, paint, benzene, thinner, gasoline, gases, and adhesive agents.

4.1.14 AVOID CONTACT WITH HOT TOOLING AND SHROUD

! CAUTION

Tooling and the machine shroud can become hot during operation and remain hot after stopped. Do not touch the tooling and shroud without proper hand protection. Failure to do so may cause injury.

The Diamond tooling and shroud become hot during operation and remain hot after stopped. Do not touch the tooling and shroud without proper hand protection.

4.1.15 KEEP FIRM GRIP ON THE MACHINE

Keep a firm hold on the handle grips and maintain control of the machine until the grinding completely stops. DO NOT tape or restrict safety handle on handle.

4.1.16 CHECK TOOLING FOR CRACKS, DAMAGE, AND MISALIGNMENT

Never use cracked, damaged, or misaligned tooling. After mounting check to see the tooling is secure.

4.1.17 DO NOT FORCE WRONG SIZE OR TYPE OF TOOLING ONTO THE MACHINE

! CAUTION

Always ensure the tooling is properly secured to the tool plates. Failure to do so may cause injury to personnel and/or damage to the machine.

Running the wrong type/size of tooling can cause damage to your machine.

4.1.18 USE EQUIPMENT AND ACCESSORIES PROPERLY

Do not force a small grinder to do the job of a heavy-duty grinder. Do not use the DX26-P for improper applications. Never cut material for which the tooling was not designed.

4.1.19 STORE EQUIPMENT AFTER USE

The machine and tools should be stored in a dry and secure location when not in use. Keep equipment out of reach of children.

4.1.20 DO NOT FORCE

The grinder will do the job better and safer at the rate for which it was designed.

4.1.21 OBTAIN MATERIAL SAFETY DATA SHEET (MSDS) FOR ALL WORK SURFACE MATERIAL

This includes primers, all coatings, adhesives, tile, and crack filling materials, etc. Do not attempt to cut, clean out or remove material without MSDS information. Consult MSDS sheet for hazards information. Be aware that some materials are explosive such as dust.

4.1.22 DO NOT OVERREACH

Always keep proper footing and balance

4.1.23 MAINTAIN MACHINE WITH CARE

Keep machine clean and follow maintenance procedures for better and safer performance. Keep handles dry, clean, and free from oil and grease. Follow instructions for lubricating and changing accessories.

4.1.24 REMOVE ADJUSTING TOOLS

ALWAYS check to see tools (such as adjustment wrenches) are removed from the machine and are properly stored before use of the machine.

4.1.25 STAY ALERT

Watch what you are doing. Use common sense. Do not operate this machine when you are tired or fatigued.

4.1.26 DO NOT USE DRUGS, ALCOHOL, MEDICATION

Do not operate machine while under the influence of drugs, alcohol, or any medication.

4.1.27 KEEP ALL PARTS IN CORRECT POSITION

Do not operate the machine with missing or improperly mounted parts.

4.1.28 CHECK PROPANE TANKS

NOTICE

- NEVER use an overfilled or liquid propane tank, doing so will damage the fuel system of this machine.
- Always use propane from a trusted source. Poor quality propane can cause engine failure and affect the normal operation of the engine.

Verify fuel levels in propane tanks before use. Make sure the selected tank is not damaged.

4.1.29 CHECK FOR DAMAGED PARTS

Upon delivery of the machine, the staff responsible should check for its completeness and any transportation damage. Any faults must be reported immediately to the supplying company.

Verify all machine guards are in good condition and will function properly before using the machine. Check for alignment of moving parts, binding of moving parts, breakage of parts, mounting, and any other conditions that may affect machine operation. A guard, power switch or other part that is damaged should be properly repaired or replaced by an authorized service center.

4.1.30 NEVER TOUCH MOVING PARTS

Never touch moving parts such as blades, belts, and others.

4.1.31 STOP OPERATION IMMEDIATELY IF ANY ABNORMALITY IS DETECTED

Stop using machine immediately if any abnormalities are observed during operation. Examples of abnormalities include unusual noise and vibration.

4.1.32 WHEN REPLACING A PART, USE THE SAME TYPE AND QUALITY

CAUTION

Never do maintenance on any part of the gearbox, engine, or fuels system while the machine is running. Failure to do so may cause injury or damage to the machine.

When replacing a component part with a new one, use only parts supplied by the manufacturer. Never attempt to repair a machine if you are unfamiliar with proper procedures and techniques required. Refer to this operations and maintenance manual as well as any additional instructions included from other manufacturers.

4.1.33 SAVE THESE INSTRUCTIONS

Refer to this operations and maintenance manual as well as any additional instructions included from other manufacturers.

4.2 LIFTING AND TRANSPORT

Parts of loading, handling, transport, unloading and lifting must only be carried out by qualified personnel with extensive experience of the DiamaPro® DX26-P along with the relevant safety rules and regulations. The means used for handling, lifting and transport must be intact and capable of performing the required operations safely, considering the size, weight, projections, delicate parts, and the center of gravity of the machine. Avoid improper uses and maneuvers, avoid all maneuvers outside the respective field of competence and responsibility. Perform handling and lifting using only the recommended means where indicated. Always use the proper PPE. Do not place hands or other body parts under raised components.

CAUTION

Slings / transport gear must consider the shape and volume and the mass indicated on the machine (crane or forklift truck) with a capacity greater than that to be lifted. Failure to do so may cause injury or damage to the machine.

DANGER

NEVER stand underneath the DX26-P when lifted. Failure to do so will cause serious injury or death in the event the machine falls.

4.2.1 LIFTING

The total weight of the machine is about 1200 lbs. The lifting must be performed from the top.

To lift the DiamaPro® DX26-P with a crane or forklift follow the steps below:

1. The machine is equipped with 4 frame cutouts. The lifting is done by being anchored to these elements in only a single central point as shown in the figure above.
2. Use a lifting device (crane or forklift)
3. The lifting gear must be approved for lifting, without imbalance, and with a load capacity exceeding the total weight of the machine.
4. Lift the machine and keep it as close to the ground as possible.
5. Avoid the machine tilting at an angle.
6. Move and lift the DX26-P with the help of one person on the ground, away from the suspended load, to give signals to the lift operator to help navigate the load when lifted.

CAUTION

Crush Hazard! Always secure wheels before changing tooling or working under the machine. Failure to do so may cause injury or damage to the machine. NEVER change tooling with a forklift.

4.2.2 TRANSPORT

The DiamaPro® DX26-P is equipped with 4 frame cutouts (shown in the figure below) on each corner of the DX26-P

To secure the DX26-P for transport, be sure to lower the third wheel until the tool plates are evenly on the ground. Attach the appropriate straps to secure the DX26-P on all 4 corners as shown in the figure below.

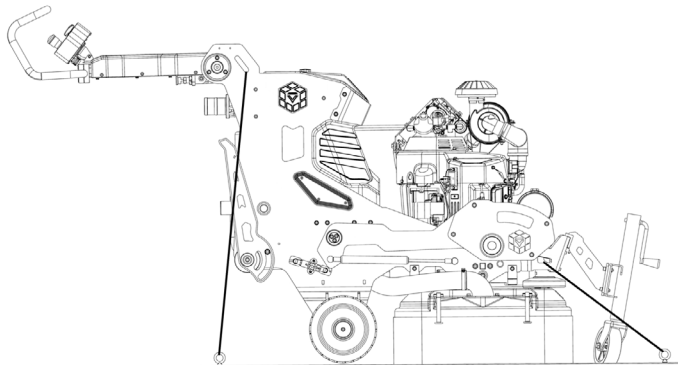
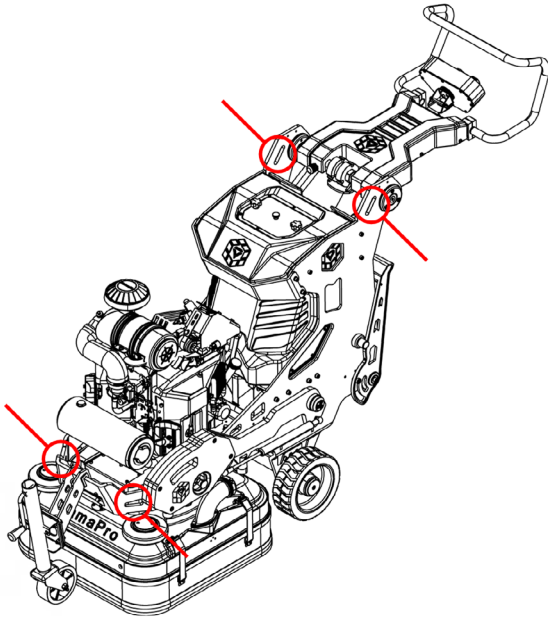

CAUTION

Use extra care when loading and unloading the machine onto a trailer or truck. Make sure the personnel responsible for loading and unloading are familiar with the machine and the loading and unloading process. Failure to do so may cause injury or damage to the machine.

4.3 STORAGE

4.3.1 STORAGE

In case the machine is not to be used immediately, please adhere to the guidelines below:

- Shut off propane tank.
- Always place the machine indoors away from areas exposed to moisture or inclement weather for storage.
- Protect unpainted parts with grease to prevent corrosion.
- Disconnect the battery.

If you plan to not use the machine for a period longer than one month:

- Close the propane tank and run out any residual fuel in the engine. Remove and properly store the propane tank.
- Remove battery if long term machine storage area average temperature drops below 40°F (4°C) or above 86°F (30°C)

4.4 MACHINE CONTROLS

The DiamaPro® DX26-P is designed and manufactured to perform floor grinding, preparation, and polishing. To operate efficiently, the machine is equipped with 4 counter rotating heads. The engine is affixed to the frame and power is transmitted via an electromagnetic clutch through a direct drive gear box to the 4 rotors. The folding handle is attached to the frame with a control panel. All the operator controls are in the control panel. This machine is operated in the standing position.

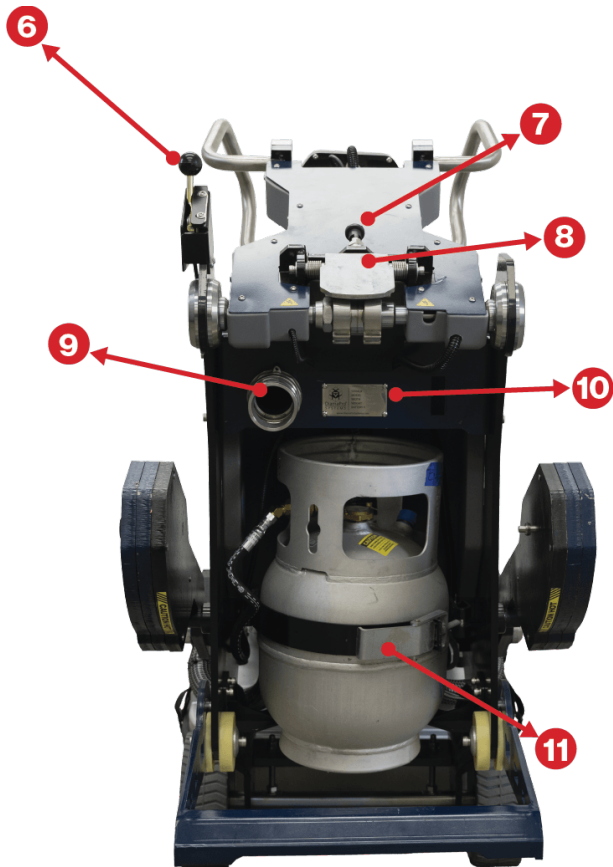
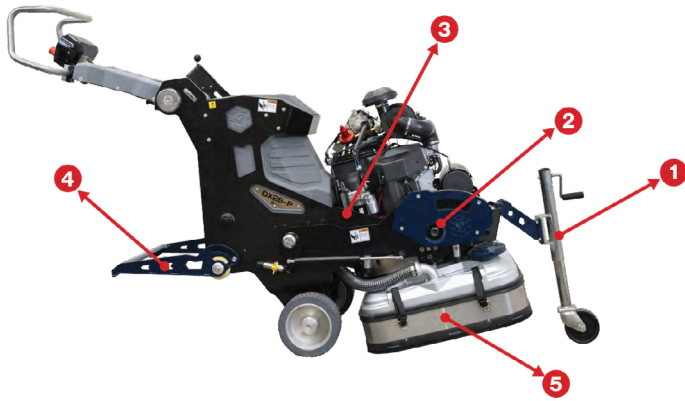

ITEM NO.	DESCRIPTION
1	Front Moving Wheel
2	Adjustable Side Weights
3	Battery Shut Off Location
4	Foot Pedal
5	Metal Dust Shroud
6	Throttle Lever
7	Adjustment Handle Lock Pin
8	Handle Adjustment
9	Dust Port Cam
10	Serial Plate
11	Propane Tank Holder
12	Clutch Switch
13	SAM Unit
14	LED Switch
15	Ignition Switch
16	E-Stop

4.5 MACHINE USE

4.5.1 WORK ENVIRONMENT

The DiamoPro® DX26-P can be operated within the temperature range of 41°F to 86°F (5°C to 30°C). It's crucial to avoid using the machine during rainy or snowy weather conditions. Only use this machine in work areas that are adequately ventilated.

CAUTION

For stability reasons it is important to use the machine on stable, relatively flat, and horizontal surface. Do not use the machine on slopes greater than 3%-4%. Failure to do so may cause injury or damage to the machine.

4.5.2 TOOL INSTALLATION

1. Turn the ignition to the off position and put the side weights into the back position
2. Fold the handle up slightly and tilt the DX26-P back all the way until the lower bump stops touching the ground.
3. Ensure no debris is present on the holders or magnets.
4. Install the appropriate uniform tooling to each tool Plate. Use the Velcro holder if using Velcro backed tooling.
5. Use Tool retention bolts to properly secure the tooling to the plates.
6. Tilt the DX26-P back until the tooling touches the ground. Level the machine if needed and adjust the handle back to the comfortable operating position.

WARNING

Always check all propane fittings are secure and no leaks are present. If leaks are present do not operate. Failure to do so may result in fire or explosion that could cause serious injury or death.

NOTICE

- NEVER use an overfilled or liquid propane tank, doing so will damage the fuel system of this machine.
- Always use propane from a trusted source. Poor quality propane can cause engine failure and affect the normal operation of the engine.

4.5.3 PROPANE TANK INSTALLATION

1. Choose the appropriate vertical vapor propane tank.
2. Ensure the tank valve is closed.
3. Unlatch the propane tank holder bracket.
4. Place propane tank in the tank holder.
5. Secure the latch.
6. Connect the DX26-P vapor supply hose securely to the propane tank.
7. Open propane tank valve and check for leaks. Shut off the propane tank immediately if leaks are detected. Move to a ventilated area and call a service center to repair.

Helpful Tip!

Always check to make sure the DX26-P's propane tank is at least half full. A low propane tank will freeze not allowing the fuel to vaporize causing the DX26-P to run poorly or fail to start.

4.5.4 STARTING PROCEDURES

1. Adjust third wheel height so that the machine is planted securely on the work area floor.
2. Remove and safely stow the third wheel and pin before beginning operation.
3. Ensure propane tank is installed and vapor supply hose is properly connected (see Section 5.3 for propane tank installation instructions).
4. Ensure the battery is connected.
5. Open propane tank valve. Shut off the propane tank immediately if leaks are detected. Move to a ventilated area and call a service center to repair.
6. Ensure the area is clear and ready for the machine to operate.
7. Turn battery breaker to the "On" Position
8. Check E-Stop to make sure it is not engaged. If engaged, twist slightly to disengage.
9. Turn the ignition key to start.
10. Raise to full throttle.
11. Engage the clutch to begin grinding
12. Adjust throttle as needed.

Helpful Tip!

If the engine does not start, return key to on position for 5-10 seconds and retry.

4.5.5 GRINDER OPERATION

To move the DX26-P, the operator must engage the clutch and walk in the desired direction. To stop the grinder movement, the operator must disengage the clutch.

4.5.5.1 HANDLE ADJUSTMENTS

1. To adjust the handles, pull the locking pin and twist to unlock.
2. Pull down on the adjustment lever and move handle to the desired position.
3. Release the adjustment lever and ensure it is locked in position.
4. Twist the locking pin to lock out the adjustment lever.

4.5.5.2 GRINDER LEVEL ADJUSTMENTS

1. Loosen the nut under the support plate on both sides of the axle to lower the rear frame of the grinder. Tighten the upper nut to lock it into place.
2. Loosen the top nut above the support plate on both sides of the axle. Tighten the lower nut under the support plate to raise the rear frame of the grinder. Retighten the top nut to lock it into place.

The DX26-P uses a direct drive system with counter rotating heads. See image below for example of head direction.

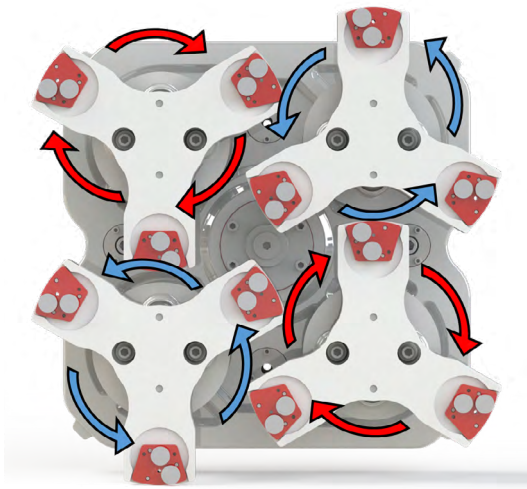

4.5.6 SHUT DOWN PROCEDURES

To stop the DX26-P, following the steps below:

1. Disengage the clutch.
2. Bring the throttle lever to idle speed.
3. Close the propane tank valve.
4. Wait for Grinder to shut off.
5. Turn the ignition key off.
6. Turn the battery circuit breaker to the "off" position.

If storing the machine, follow section 4.3.1 in this manual for proper procedures.

CAUTION

Before carrying out the maintenance of DiamaPro® Systems DX26-P, make sure you understand the contents of this manual. Please contact the manufacturer for further explanations and information. Failure to do so may cause injury or damage to the machine.

Before carrying out the maintenance of the machine make sure you understand the contents of this manual. Please contact the manufacturer for further explanations and information. Maintenance workers must possess the skills required by this manual, as well as the mental and physical requirements necessary and sufficient to maintain and operate the machine. To ensure the functionality and durability of the machine daily maintenance must be performed, carrying out operations in compliance with the safety requirements. Only the authorized dealer can adjust and perform operations that are not assigned to the operator. It is forbidden to make adjustments and interventions during machine operation. Before performing any maintenance operation disconnect the machine from the power sources and wait for the cooling of the hot parts (engine, spark-plug area, air filter area, etc.)

Follow the safety steps below before performing any maintenance or repairs:

- Follow all safety decals and placards.
- Ensure all fuel sources are turned off and / or removed.
- Ensure the key switch is turned to the off position.
- Disconnect the battery quick connection.
- Wear all the necessary PPE.
- Always utilize provided stands with safety pins installed correctly on all 4 corners when lifting and / or changing of tooling or foam pads.
- Secure all wheel locks to prevent unwanted movement during service or storage.
- If machine operation is required for troubleshooting task ensure appendages are clear of any rotational parts, pinch points, and crush zones.
- Allow machine to properly cool for engine related tasks.

It is also recommended for proper maintenance to:

- Thoroughly clean the DiamaPro® DX26-P. If in doubt about how to perform occasional repairs, contact our Technical Support or an authorized dealer.
- Perform a thorough cleaning from processing residues upon finishing the job.

NOTICE

Avoid splashing water on engine and all electronics during cleaning. Cover when possible. ALWAYS ensure the engine is cooled before covering.

5. MAINTENANCE & REPAIR

CAUTION

During the execution of maintenance tasks, you must wear the following P.P.E.: CUT RESISTANT GLOVES, SAFETY GLASSES AND SAFETY SHOES. For certain types of activities (lubricant filling-up) make use of airway protection equipment as indicated in the residual risks.

CAUTION

Never do maintenance on any part of the gearbox, engine, or fuels system while the machine is running. Failure to do so may cause injury or damage to the machine.

5.1 SCHEDULED MAINTENANCE

Good maintenance requires constant and methodical control of all parts of the machine and adaptation of tests to its actual usage. Periodic inspections are crucial to keep the machine efficient and reduce repairs and any resulting dangers.

We recommend that you have your DiamaPro® DX26-P serviced by an authorized dealer or a DiamaPro® Systems technician every 500 hours.

Note: frequency is taken over considering a working day of 8 hours.









CAUTION







Some operations of maintenance / replacement of worn components may only be carried out by the authorized dealer or the manufacturer's technician.

They are reported later in this publication. Please note that failure to comply with the requirements of maintenance represents a possible MISUSE or PROHIBITED USE and relieves the manufacturer from any liability for damage to persons and property.

OPERATION	HOUR INTERVAL																			
	8-50	100	150	200	250	300	350	400	450	500	550	600	650	700	750	800	850	900	950	1000
Check gearbox seals for leaks	X	X	X	X	X	X	X	X	X	X	X	X	X	X	X	X	X	X	X	X
Change oil & oil Filter	X	X	X	X	X	X	X	X	X	X	X	X	X	X	X	X	X	X	X	X
Inspect drive belt(s) tension	X	X	X	X	X	X	X	X	X	X	X	X	X	X	X	X	X	X	X	X
Replace air filter & Pre-filter	X	X	X	X	X	X	X	X	X	X	X	X	X	X	X	X	X	X	X	X
Replace spark plugs		X		X		X		X		X		X		X		X		X		X
Inspect gear oil. Replace if needed.		X		X		X		X		X		X		X		X		X		X
Replace belts					X					X					X					X
Check battery with load tester. Replace if needed					X					X					X					X
Inspect clutch. Replace if needed																				X

FREQUENCY	PROCEDURES
FIRST 8 HOURS (BREAK IN PERIOD)	-CHANGE OIL & OIL FILTER -INSPECT CLUTCH BELT TENSION -TILT MACHINE BACK AND INSPECT GEARBOX SEALS AROUND EACH GRINDING HEAD
EVERY 50 HOURS	-CHANGE OIL & OIL FILTER -CHECK & CLEAN OIL COOLER FINS
EVERY 100 HOURS	-REPLACE SPARK PLUGS -INSPECT CLUTCH BELT TENSION
EVERY 250 HOURS	-CHECK BATTERY WITH LOAD TESTER. REPLACE IF NEEDED -REPLACE PRIMARY & SECONDARY AIR FILTER -CHECK VALVE CLEARANCE. ADJUST IF NEEDED.
EVERY 250 HOURS	-INSPECT RUBBER IN FLEXIBLE TOOL PLATE MOUNT FOR DAMAGE OR EXCESSIVE WEAR. REPLACE AS NEEDED
EVERY 500 HOURS	-REPLACE CLUTCH BELT
EVERY 1000 HOURS	-INSPECT ELECTROMAGNETIC CLUTCH. REPLACE IF NEEDED. -INSPECT ANTI-ROTATION. REPLACE IF NEEDED -REPLACE GEAR OIL

NAME OF OPERATION	FREQUENCY	PERSON IN CHARGE	OPERATING INSTRUCTIONS	STATE OF MACHINE
MECHANICAL PARTS				
General Cleaning	At each start		Wash the dirty parts with a brush and water. Lubricate the parts exposed to dust; Do not lubricate the rubber parts subjected to motion (belts, etc).	Machine stopped /Power sources disconnected
Engine Air Filter	At each start		Check and Clean engine air filter if necessary, especially if you are working in dusty conditions or replace it; follow the instructions given in the engine	Machine stopped /Power sources disconnected
Grinding Heads	At each start		Lift the gearbox grinding head, check whether the abrasive positioning pins are loose or damaged, and replace them if necessary	Machine stopped /Power sources disconnected
Engine Oil Level	At each start		Add oil if low or replace oil & oil filter if needed	Machine stopped /Power sources disconnected
Wheels & Wheel Bearings	At each start		Inspect wheels & wheel bearings for damage or excessive wear. Replace if needed.	Machine stopped /Power sources disconnected
Dust Control System	At each start		Inspect dust skirt and dust hoses for damage or excessive wear. Replace if needed.	Machine stopped /Power sources disconnected
Check Propane Level & Supply	At each start		It is recommended to make sure that the propane contains no water and not to use mixtures or diesel. Perform this operation in a well-ventilated environment and away from possible sources of heat or flames. Make use of specific P.P.E. (mask) as shown in the residual risks table of this publication. REFER TO THE ENGINE MANUAL	Machine stopped /Power sources disconnected
Battery	Weekly Or every 40 hours		The DX26-P is equipped with a maintenance-free battery. DO NOT TRY TO FILL. Clean the two battery poles to remove oxidation. It is recommended to turn off the battery via the circuit breaker on the side of the grinder when storing or transporting the machine	Machine stopped /Power sources disconnected

NAME OF OPERATION	FREQUENCY	PERSON IN CHARGE	OPERATING INSTRUCTIONS	STATE OF MACHINE
MECHANICAL PARTS				
Gearbox	Weekly Or every 40 hours		<p>The gearboxes are sealed upon assembly; if you notice oil leaks, carefully find out their origin because there may be leaks from other sources. If the leaks come from the gearbox, contact our technical service or a qualified technician.</p> <p>Clean any oil leaks at the bottom of the grinder. For a possible change of the lubricant due to leaks or for the topping up operations, use the following type of lubricant: MOBIL SCH 630</p> <div style="background-color: #cccccc; padding: 5px; text-align: center;"> <p>CAUTION</p> <p>DO NOT REPLACE THE GEARBOX. CONTACT DIAMAPRO® SYSTEMS OR THE AUTHORIZED DEALER.</p> </div>	Machine stopped /Power sources disconnected
Oil Cooler	Weekly Or every 40 hours		Check & clean any dust or debris, especially if you are working in dusty conditions	Machine stopped /Power sources disconnected
Spark plugs	Weekly Or every 40 hours		<p>Inspect Spark Plugs. If you need a replacement, refer to the engine manual.</p> <p>Be careful when removing the spark plug:</p> <ul style="list-style-type: none"> • wait for the engine to cool down; • remove the cap; • remove the spark plug down away from the spark plug holder (because spark may be triggered). 	Machine stopped /Power sources disconnected
Clutch Belt	Weekly Or every 40 hours		Check belt for proper tension or abnormal wear. Replace if needed	Machine stopped /Power sources disconnected
SAFETY SYSTEMS				
Safety Systems	Daily		Please note the requirement to perform the checking and recording of verifications of safety components every 6 months.	Machine Stopped
Integrity of Pictograms	Weekly Or every 40 hours			Machine stopped /Power sources disconnected

5.2 ROUTINE & ADDITIONAL MAINTENANCE

5.2.1 BATTERY REPLACEMENT & MAINTENANCE

To stop the DX26-P, follow the steps below:

⚠️ WARNING

- Always check both battery terminals are securely connected with terminal boots. Loose or exposed battery terminals can result in a spark which could lead to fire or explosion that could cause serious injury or death.
- Always check battery cables and wires for damage. Damaged cables can cause fire which could cause serious injury or death.
- Do not short-circuit the positive and negative terminals of the battery. Doing so may result in fire or explosion that could cause serious injury or death.

1. Turn the battery circuit breaker to the “off” position.

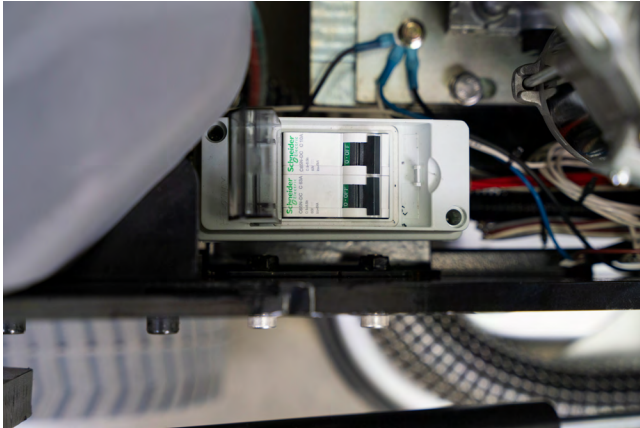

2. If present, disconnect and remove the propane tank.
3. Remove the connection terminals (a) and (b) taking care to remove first the negative, black color (a) to prevent possible damage.



4. Remove the battery and replace it with a battery having the same specifications.

⚠️ CAUTION

Replace only with manufacturer recommended battery (P/N: W4359)
Use of non-OEM Battery may result in harm to user, damage to the machine, and/or violation of the machine's warranty.

Helpful Tip!

The OEM battery is non-spillable and does not require fill maintenance.

5. Replace all terminal boots.

When charging a battery be sure to follow these steps below:

1. Disconnect the battery by means of the quick disconnects.
2. Remove the enclosing lid by removing the retaining screw.
3. Using a multi-meter battery voltage can be determined. If it is less than 11v the battery may require charging or replacement.
4. Remove the battery and set it on a safe stable surface.
5. Connect the battery charging clamps firmly to the correct terminal posts.
6. Repeat steps 3 when complete. If the battery is less than 11v battery may need to be replaced.

⚠️ CAUTION

NEVER jump start the DX26-P using a vehicle as the voltage source could damage the system. Failure to comply represents a MISUSE or PROHIBITED USE and may result in harm to user, damage to the machine, and/or violation of the machine's warranty.

NOTICE

Only recharge the battery in a dry environment. Protect the contacts from dirt and moisture stagnation. Don't spray with water.

5.2.2 OIL CHANGE

Refer to the engine manual attached and to the MAINTENANCE CHAPTER OF THIS PUBLICATION. The oil filling must be performed with the machine off after waiting for the cooling of hot parts.

1. First proceed by draining the oil pan by removing the cap on the drain tube and turn the lever to open the valve, visible in the following figure.



2. Once fully drained recap the drain tube.
3. Remove the old oil filter and replace it with a new certified Oil Filter (ROG-60V9135).



4. Locate and remove the oil fill cap on the front valve cover. Then add 2.5 quarts of 10w30 oil.
5. Verify the oil level on the graduated dipstick.



6. Re-secure the oil fill cap back on the valve cover.

NOTICE

TO AVOID DAMAGE TO THE MACHINE STRICTLY follow the engine manufacturer's recommended oil in the manual provided with the machine. 10W-30 is recommended.

Oil Viscosity

Choose the viscosity according to the temperature as follows:

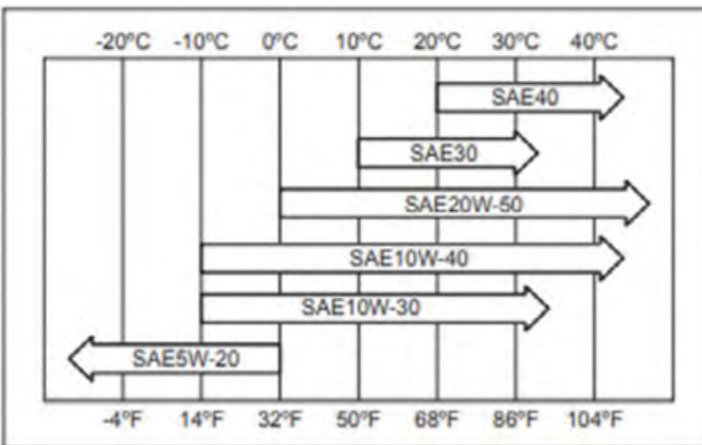

Helpful Tip!

Although 10W-30 engine oil is the recommended oil for most conditions, the oil viscosity may need to be changed to accommodate atmospheric conditions. Please contact the authorized dealer if running machine in extreme conditions for the correct oil choice.

5.2.3 Air Filter Change

It is recommended to always check the engine air filter and prefilter before each job. If during inspection the air filter is dirty or clogged follow the steps below:

1. Remove the airbox lid by using the two clamps on the sides.

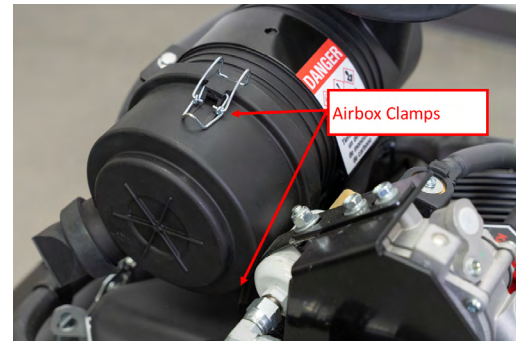

2. Remove the main filter.



3. Inspect the pre-filter, remove & replace if needed.

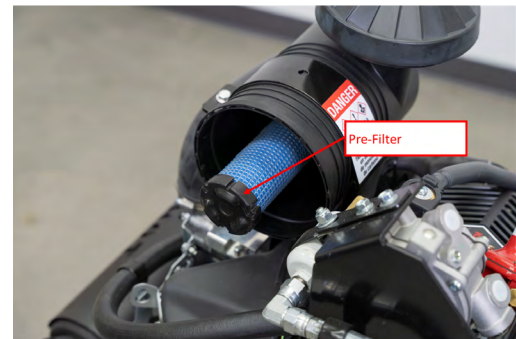

4. Replace main filter.



5. Reattach and clamp the airbox lid.

5.2.4 Belt Change

To tension the belts please refer to step XX below. If, by visual inspection, it appears that the belts are worn or cracked, replace as follows:

1. Remove the propane tank and ensure the clutch is disengaged.
2. Set the battery circuit breaker to the off position.
Allow machine to cool before preceding
3. Remove the dust port opposite of the oil fill side of the engine (Older models will remove the dust port on the oil fill side).
4. Remove the belt access panel on the side that the dust port was removed.
5. Remove the front belt access cover.
6. Check the belt is tensioned properly and does not show excessive wear or damage. If the belt is damaged, continue the following steps. If the belt needs to be tensioned skip steps 10 & 11.
7. Loosen the 6 bolts on the side of the engine.
8. Loosen the retention nut on the tensioner bolt.
9. Unscrew the tensioner to relieve tension on the belt.
10. Remove the belt first by removing from under the clutch pulley, then by removing the belt over the gearbox pulley.
11. Install the new belt on the side without the tensioner. First over the gearbox pulley then under the clutch pulley.
12. Adjust tensioner to the proper tension (750-800 using the Optikrik). Set the retention nut.
13. Tighten the 6 hex bolts to set the motor.
14. Reinstall the front belt cover.
15. Reinstall the side belt cover.
16. Reinstall the side dust port & hose.

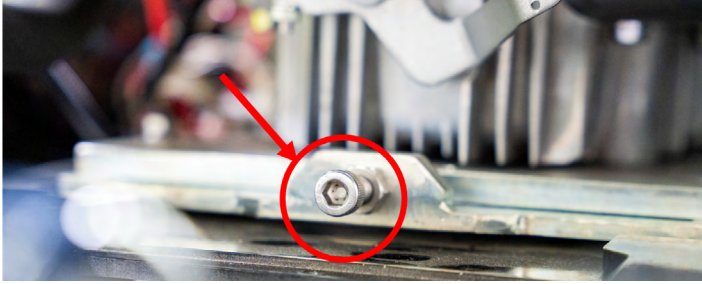

TENSIONER

5.2.5 Gearbox Service

The machine is equipped with a single direct drive gearbox. Periodically check the oil level of the gearboxes and top off as needed. There is a cap visible on top of the gearbox.

If oil is present underneath the machine, perform a thorough cleaning and check the origin of the leak. If topping off is necessary, proceed as follows:

1. Remove the fill cap from the gearbox.

NOTICE

TO AVOID DAMAGE TO THE MACHINE STRICTLY follow the manufacturer's recommended oil in the manual provided with the machine. Mobil SHC 630 Gear Oil (DP-GH-SHC630) is recommended.

2. Add gear oil as needed to cover the gears.
3. Replace fill cap.
4. When performing a system flush utilize the drain cap first to remove all gear oil. Then reinstall the drain cap.
6. Then, follow the refill steps above.



TRANS FLUID ACCESS

5.3 NOTES ON DISMANTLING

Regarding dismantling activities, there are no security-related or environmental problems. In case you wish to proceed with the dismantling of the various machine parts, it is necessary to pay attention to their movement, considering the respective masses to be handled. In the case of machines used in working environments it is necessary to dispose of the electrical and electronic products, if any, contained in them in accordance with the current legislation.

NOTICE



Do not dispose into the environment products which are not biodegradable, lubricant oils and relevant filters as well as non-ferrous parts (rubber, PVC, etc.). Perform their disposal in accordance with the laws in force and before taking care of this disposal, consult your authorized dealer in order to check whether there are specific programs of withdrawal.

NOTICE

At the time of dismantling, the user shall be required to recover the identification plate of the equipment to prevent the machine from being put back into service without its guards because the
MANUFACTURER IS NO LONGER HELD RESPONSIBLE.

ISSUES	CAUSES	REMEDIES
Grinder oil leakage	Gearbox cover screws are loose	Tighten the screws
	Faulty Seals	Contact the authorized service center
	Oil seals on central and lateral shaft worn	Contact the authorized service center
	Engine oil leakage	Contact the authorized service center
Engine doesn't start	E-stop engaged	Disengaged E-stop
	Battery circuit breaker turned off	Turn on battery circuit breaker
	Low Fuel	Replace/Fill propane tank
	Fuel tap closed	Open the propane valve (*)
	Propane filter clogged	Replace the filter (*)
	No spark	Clean the spark plug and if necessary, replace it (*) Check the connection pin (*)
	Flooded engine / ignition trouble	Unscrew the spark plug and dry it
Engine speed falls	Accelerator broken or bent	Replace accelerator cable
	Engine trouble	Contact the authorized service
	Dirty carburetor	Contact the authorized service
	Clogged air filter	Clean or replace air filter (*)
	Frozen propane tank	Replace propane tank Wait for propane to thaw
Rotor(s) do not turn when grinder is running	Clutch not engaging	Check clutch switch is engaged. Check clutch connections Contact authorized service center
	Loose/Worn/Damaged Belt	Tighten the transmission belts or replace them
	Damaged shear key	Replace damaged shear key
Grinder jumps on floor	Tooling uneven or missing	Check tooling Ensure locking bolt is installed to tooling
	Grinder unlevel	Level grinder
	Damaged tool plates	Replace damaged tool plates
	Damaged shear key	Replace damaged shear key
	Insufficient weight	Lower side weights

(*) REFER TO THE ENGINE MANUAL



DX26-P PARTS LIST

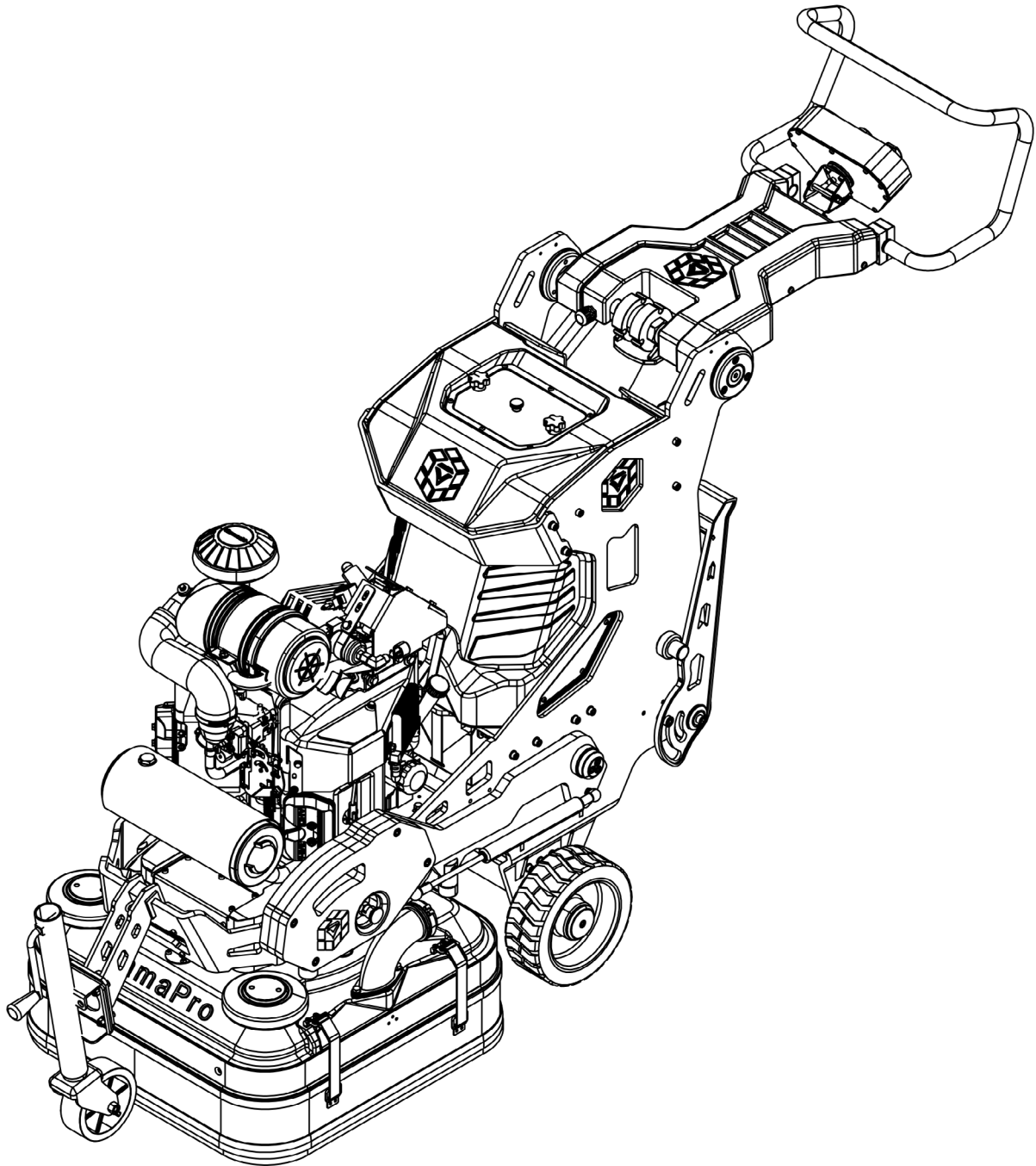

GENERAL PARTS

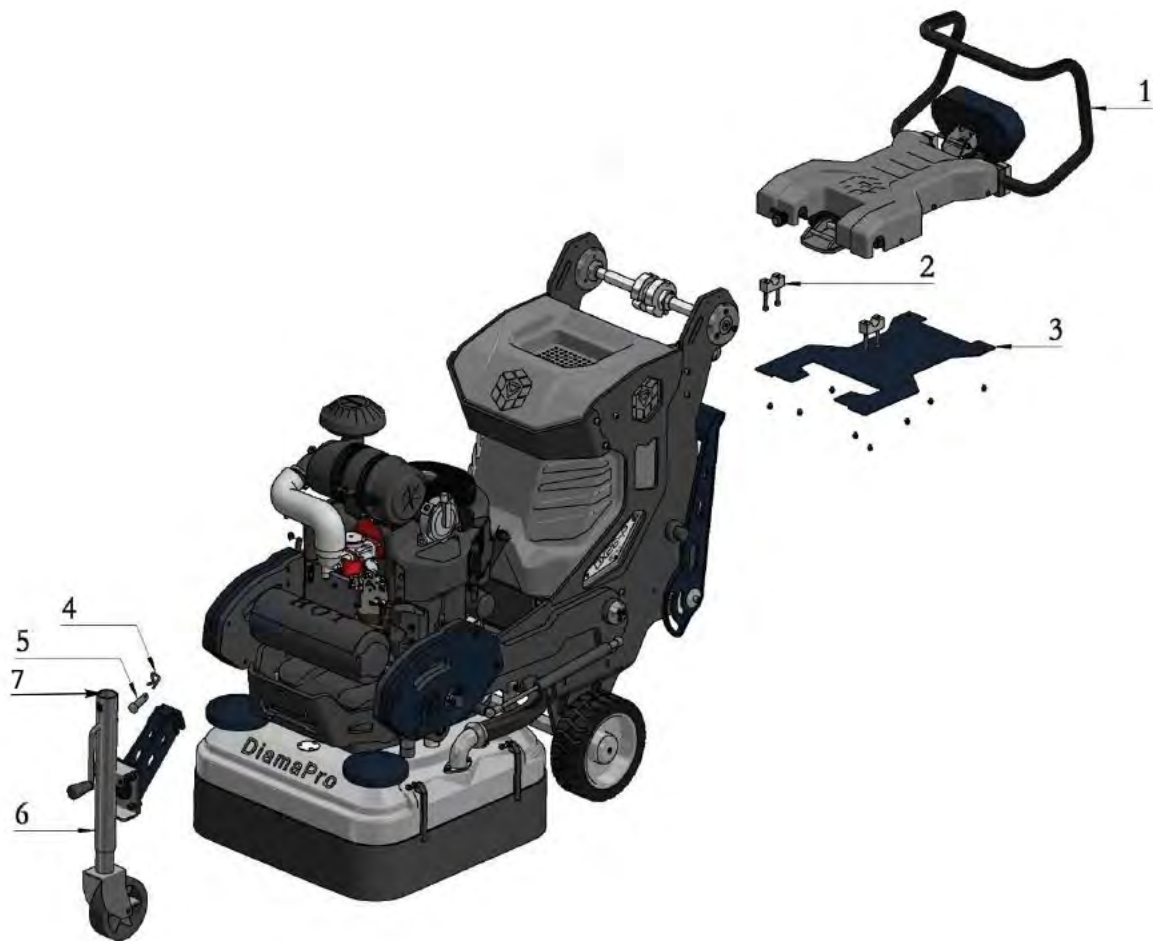

ITEM NO.	PART NUMBER	DESCRIPTION	QTY.
1	DP-DX26-HASM	HANDLE ASSEMBLY	1
2	DP-DX26-HDPL	HANDLE PLATEN	1
3	DP-DX26-HBPL	HOUSING BOTTOM PLATE	2
4	DP-DX26-RPIN	COTTER PIN FOR FRONT MOVING WHEEL	1
5	DP-DX26-DPIN	DOWEL PIN FOR FRONT MOVING WHEEL	1
6	DP-DX26-FMWH	FRONT MOVING WHEEL	1
7	DP-DX26-FMWH-C	FRONT MOVING WHEEL DUST CAP	1

HANDLE ASSEMBLY

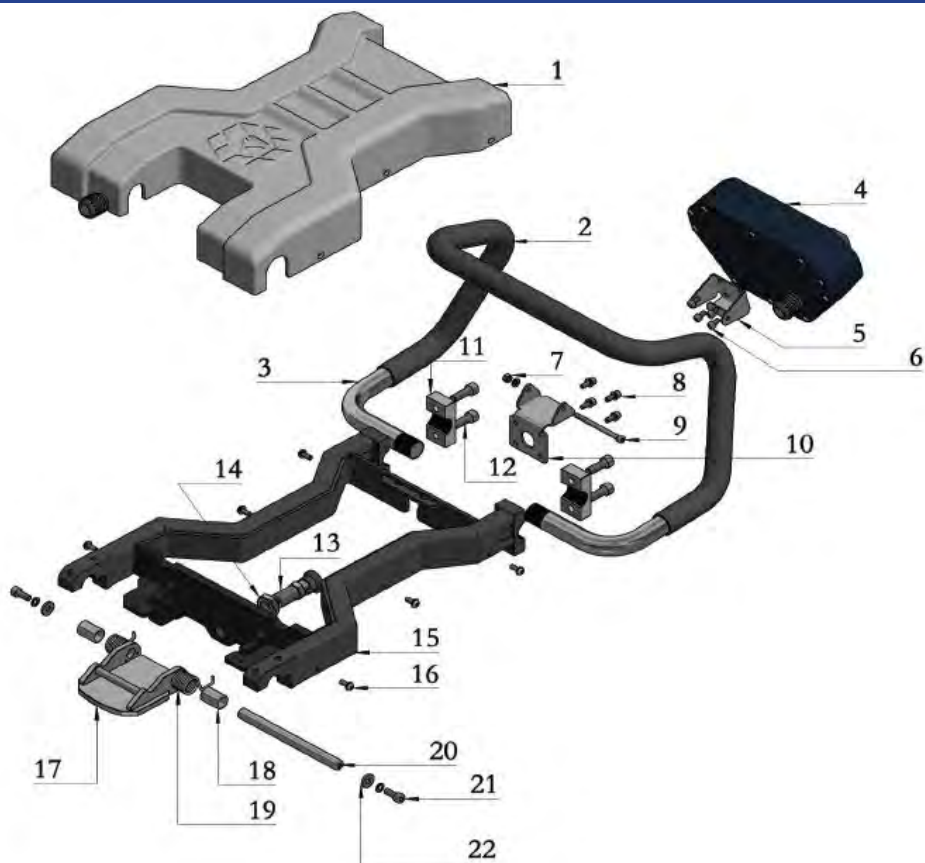

ITEM NO.	PART NUMBER	DESCRIPTION	QTY.
1	DP-DX26-HDCV	HANDLE COVER	1
2	DP-DX26-HDSL	HANDLE SLEEVE	1
3	DP-DX26-OPHD	OPERATION HANDLE	1
4	DP-DX26-OPCB	OPERATION CONTROL BOX	1
5	DP-DX26-OCBB	OPERATION CONTROL BOX BASE - UPPER	1
6	DP-GH-DX0290	M6 x 10 BUTTON HEAD HEX BOLT	4
7	DP-NUT-M6	M6 NUT	1
8	DP-GH-DX0293	HEXAGON SOCKET BOLT M6x15	4
9	DP-HSB-M6X80	HEXAGON SOCKET BOLT M6x80	1
10	DP-DX26-CNBB-B	CONTROL BOX BASE	1
11	DP-DX26-HDPL	HANDLE PLATEN (LARGE GROOVE)	1
12	DP-GH-DX0267	HEXAGON SOCKET BOLT M10x30	4
13	DP-DX-IDP20	HANDLE ADJUSTMENT PIN	1
14	DP-DX26-PSGG	POSITIONING NUT	1
15	DP-DX26-OHRR	OPERATING HANDLE FRAME	1
16	DP-GH-DX0289	M6 x 16 BUTTON HEAD HEX BOLT	6
17	DP-DX26-AJDD	ADJUSTMENT HANDLE	1
18	DP-DX-SRSS	SPRING POSITIONING SHAFT BUSING	2
19	DP-DX-SRPP	SPRING (LEFT AND RIGHT SYMMETRY)	2
20	DP-DX-SRST	SHAFT POSITIONING SPRING	1
21	DP-GH-DX0278	HEXAGON SOCKET BOLT M8x20	2
22	DP-BWSH-0001	M8 WASHER	2

FRAME

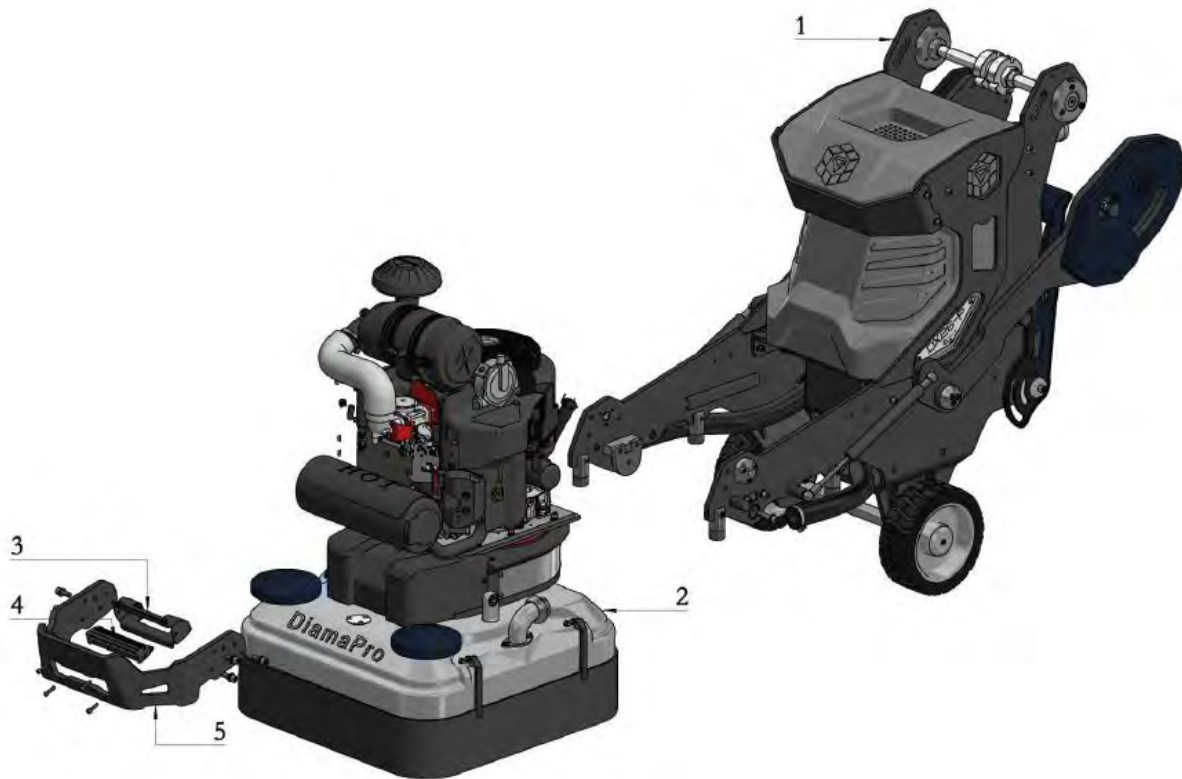

ITEM NO.	PART NUMBER	DESCRIPTION	QTY.
1	DP-DX26-BODY	BODY ASSEMBLY	1
2	DP-DX26-GBOX	GEAR BOX ASSEMBLY	1
3	DP-DX26-LEDB	LED LIGHT BRACKET	1
4	DP-DX26-LLED	LED LIGHT	1
5	DP-DX26-BFMW	FRONT MOVING WHEEL BRACKET	1

CARRIAGE



CARRIAGE

ITEM NO.	PART NUMBER	DESCRIPTION	QTY.
1	DP-DX-HCST	HANDLE CONNECTION SHAFT	1
2	DP-PIN-8X7X25	PIN 8X7X25	2
3	DP-DX-HGAB	HANDLE GEAR ADJUSTMENT BASE	1
4	DP-DX-ABPN	ADJUSTMENT BASE POSITIONING NUT	1
5	DP-DX-HCSC	HANDLE CONNECTION SHAFT BAFFLE	2
6	DP-DX-SPP	HANDLE CONNECTION SHAFT POSITIONING PLATE	2
7	DP-GH-DX0130	HEXAGON SOCKET BOLTS M8x35	6
8	DP-GH-DX0296	COUNTERSUNK BOLT M12 x 35	2
9	DP-DX-HCSP	HANDLE CONNECTION SHAFT PLUG	2
10	DP-DX26-GSWA	GROUND STOP WHEEL - A	2
11	DP-DX26-GSWB	GROUND STOP WHEEL - B	2
12	DP-DX26-FTPD	FOOT PEDAL	1
13	DP-DX26-PPSF	PEDAL POSITIONING SHAFT	2
14	DP-DX26-FPPP	FOOT PEDAL POSITIONING PLUG	4
15	DP-GH-DX0267	HEXAGON SOCKET BOLT M10x30	4
16	DP-DX26-PSTP	PEDAL STOPPER	2
17	DP-GH-DX0267	HEXAGON SOCKET BOLT M10x30	2
18	DP-DX26-WWSH	WEIGHT WASHER	2
19	DP-DX26-WABL	WEIGHT ASSEMBLY (1 LEFT/RIGHT SYMMETRICAL)	2
20	DP-DX26-GASS	GAS SPRING	2
21	DP-DX26-WPLG	WEIGHT PLUG	2
22	DP-GH-DX0271	HEXAGON SOCKET BOLT M8x25	6
23	DP-GH-DX0280	HEXAGON SOCKET BOLT M10x55	4
24	DP-DX26-MEBP	MOUNTING EAR BASE CONNECTING PLATE	2
25	DP-DX26-MTEB	MOUNTING EAR BASE	4
26	DP-GH-DX0271	HEXAGON SOCKET BOLT M8x25	4
27	DP-DX26-GBTR	GEAR BOX TOP ROD	4
28	DP-DX26-RBFT	RUBBER FOOT PADS	4
29	DP-GH-DX0267	HEXAGON SOCKET BOLT M10x30	4
30	DP-GH-DX0271	HEXAGON SOCKET BOLT M8x25	6
31	DP-DX26-WPNS	WEIGHT PIN SEAT	2

FRAME / WHEEL ASSEMBLIES

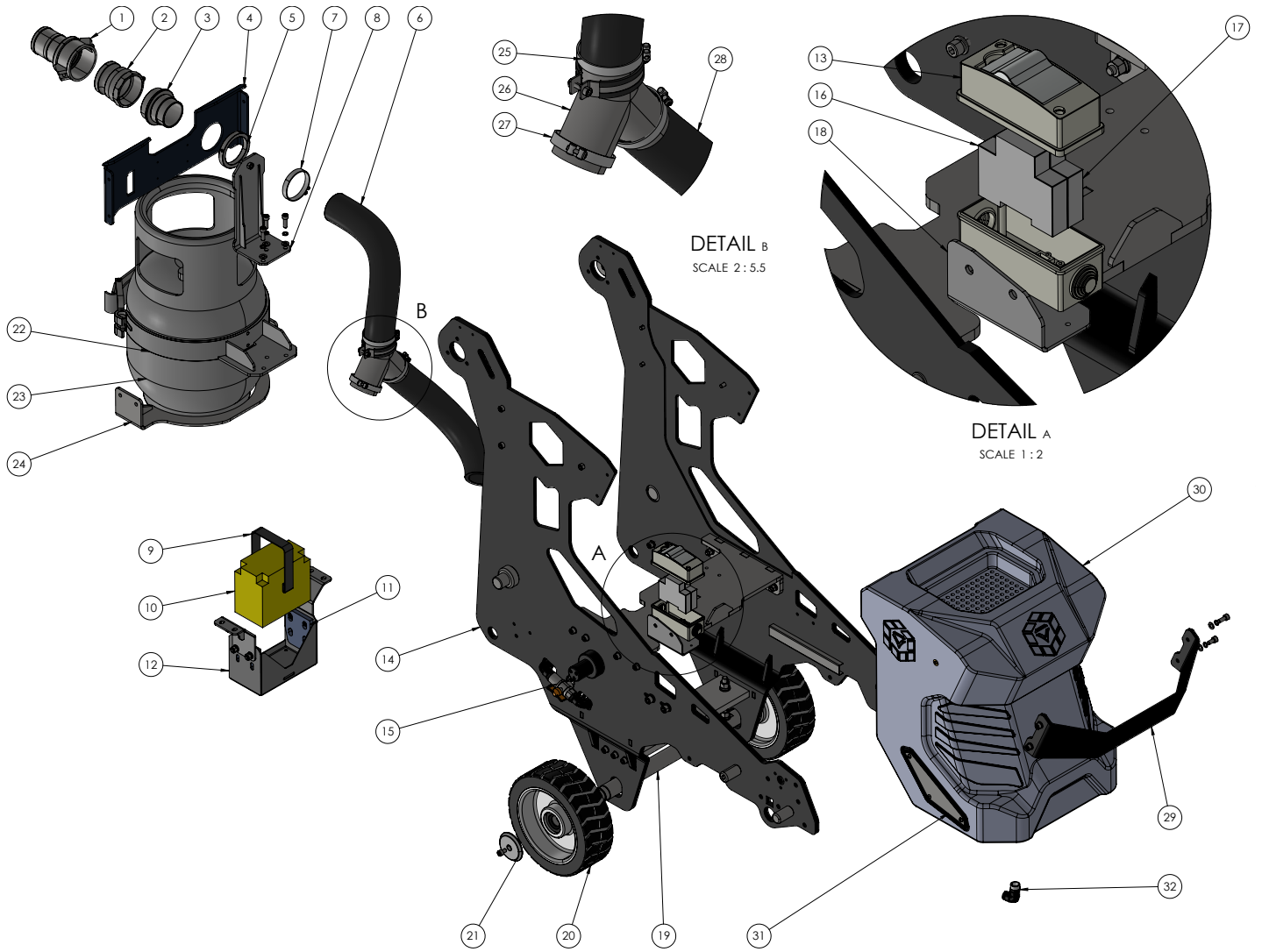

LOWE FRAME / WHEEL ASSEMBLY

ITEM NO.	PART NUMBER	DESCRIPTION	QTY.
1	DP-DX-FCL25	CAM LOCK 2.5 INCH A	1
2	DP-DX-MCL25	CAM LOCK 2.5 INCH B	1
3	DP-DX26-AVAC	VACUUM ADAPTER	1
4	DP-DX26-FRMP	BRACKET CONNECTION PLATE	1
5	DP-DX26-DPFN	DUST PIPE FIXING NUT	1
6	DP-DX26-VHSE-A	VACUUM HOSE A	1
7	DP-CLMP-5276	VACUUM HOSE CLAMP 52-76MM	2
8	DP-DX26-V3WB	VACUUM PIPE SUPPORT BRACKET	1
9	DP-DX26-BSTP	BATTERY STRAP	1
10	DP-DX26-BTRY	BATTERY	1
11	DP-DX26-RBPD	RUBBER BACKER PAD	2
12	DP-DX26-BVBR	BATTERY BOX BRACKET	1
13	DP-DX-BBOX	BREAKER BOX (WATER PROOF CASE)	1
14	DP-DX26-FRME	FRAME	1
15	DP-DX26-WTVS	WATER VALVE SWITCH	1
16	DP-DX-BTBR	BATTERY CIRCUIT BREAKER (63AMP)	1
17	DP-DX-BYSW	BATTERY CIRCUIT BREAKER (10AMP)	1
18	DP-DX26-BIBP	BREAKER BOX BOTTOM PLATE	1
19	DP-DX26-WAXL	WHEEL AXLE	1
20	DP-DX-WHEEL	WHEEL	2
21	DP-DX-WWPG	WALKING WHEEL PLUG	2
22	DP-DX26-GTCP	GAS TANK CLAMP	1
23	VAPOR-TANKSVAPOR-TANKSTEEL-20#	PROPANE GAS TANK	1
24	DP-DX26-LTSB	LOWER TANK SUPPORT BRACKET	1
25	DP-DX26-MTCP	VACUUM Y-TUBE HOSE CLAMP	1
26	DP-DX26-V3WY	VACUUM Y-TUBE	1
27	DP-DX26-VACL	VACUUM HOSE CLAMP 33-57MM	4
28	DP-DX26-VCHS	VACUUM HOSE B	2
29	DP-DX26-WTBB	WATER TANK BRACKET	1
30	DP-DX26-WTNK	WATER TANK	1
31	DP-DX26-LGLL	LOGO NAMEPLATE	2
32	DP-DX26-PPCC	PIPE CONNECTOR	1

ENGINE BASE

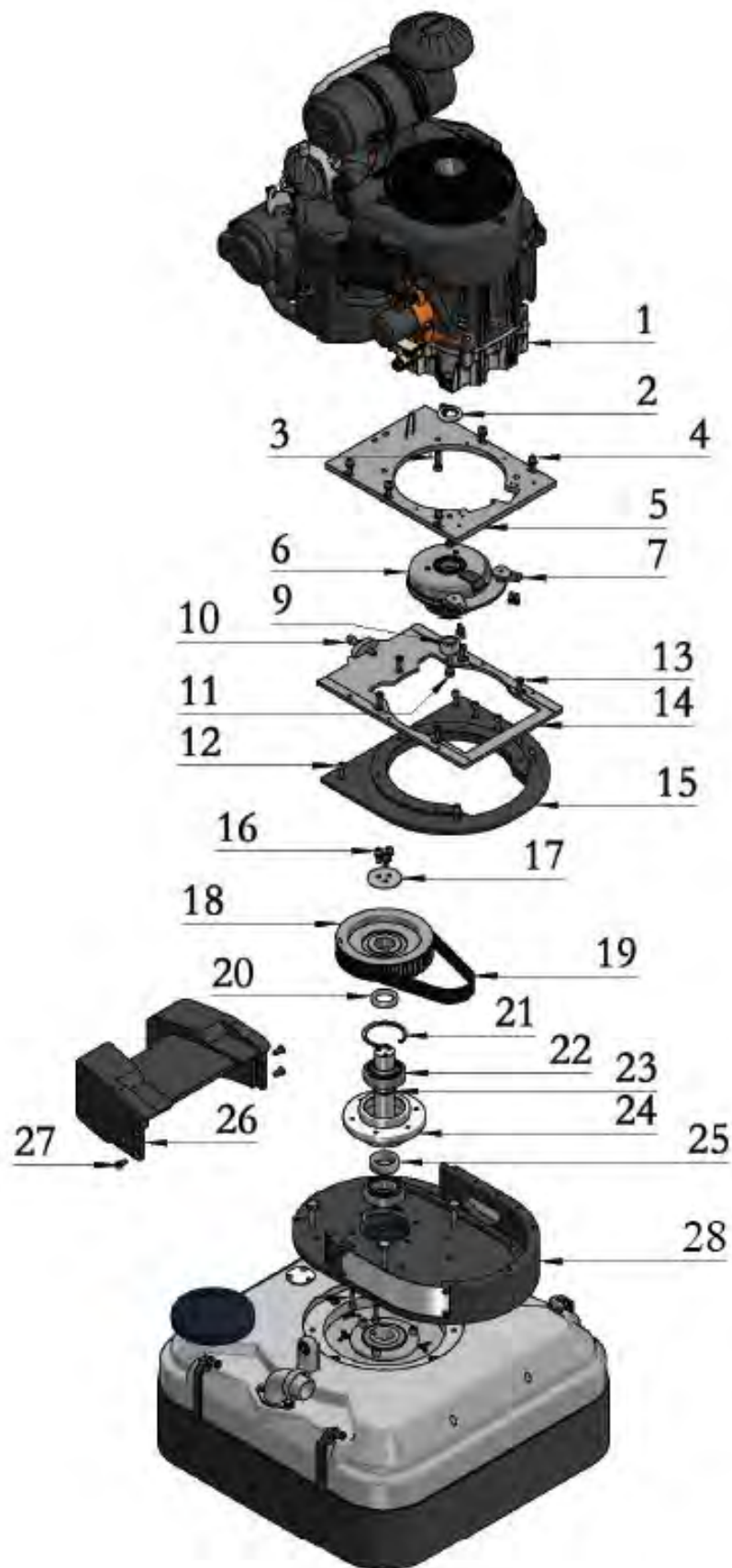

ENGINE BASE

ITEM NO.	PART NUMBER	DESCRIPTION	QTY.
1	DP-DX26-PENG	PROPANE ENGINE	1
2	DP-DX26-EGSL	ENGINE INNER SHAFT SLEEVE BRACKET	1
3	DP-GH-DX0276	HEX BOLTS - INCH 3/8-16x1.25	4
4	DP-GH-DX0268	MOTOR MOUNTING HARDWARE KIT	6
	DP-GH-DX0269	M8 SPLIT WASHER	15
	DP-GH-DX0270	M8 FLAT WASHER	15
5	DP-DX26-EGFL	ENGINE FLANGE	1
6	DP-DX26-CLUT	ELECTROMAGNETIC CLUTCH	1
7	DP-GH-EMCAR-K	ANTI-ROTATION PIN ASSEMBLY	2
9	DP-DX26-ENGB	ENGINE BUSHING	1
10	DP-GH-DX0264	SOCKET HEAD TENSIOING BOLT M10x60	1
11	DP-DX-CLB	CLUTCH BOLT (7/16-14x1.75)	1
12	DP-GH-DX0122	HEXAGON SOCKET BOLT M8x40	7
13	DP-GH-DX0272	HEXAGON SOCKET BOLT M8x30	5
14	DP-DX26-ENFP	ENGINE FLANGE FIXING PLATE	1
15	DP-DX26-GBA1	GEARBOX ASSEMBLY 1	1
16	DP-GH-DX0278	HEXAGON SOCKET BOLT M8x20	3
17	DP-DX26-WSTP	SYNCHRO WHEEL STOPPER	1
18	DP-DX26-SYWH	SYNCHRONOUS WHEEL 185	1
19	DP-DX26-SYBT	SYNCHRONOUS BELT	1
20	DP-DX26-SYBS	SYNCHRONOUS WHEEL BUSHING	1
21	DP-DX26-CN80	CIRCLIP 80MM	2
22	DP-BEAR-6208	BEARING 6208	2
23	DP-DX26-SWDS	SYNCHRONIZED WHEEL DRIVE SHAFT	1
24	DP-BEAR-6208-BASE	BEARING BASE 6208	1
25	DP-BEAR-6208-WASH	BEARING WASHERS	1
26	DP-DX26-GRBB	GEARBOX BODY	1
27	DP-GH-DX0272	HEXAGON SOCKET BOLT M8x20	4
28	DP-DX26-GRA2	GEARBOX ASSEMBLY 2	1

TRANSMISSION ASSEMBLY

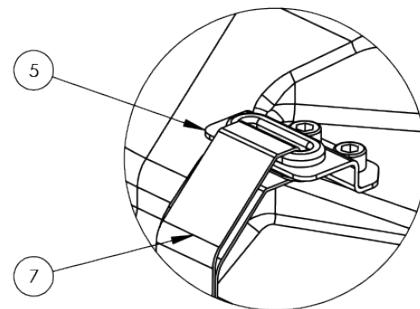
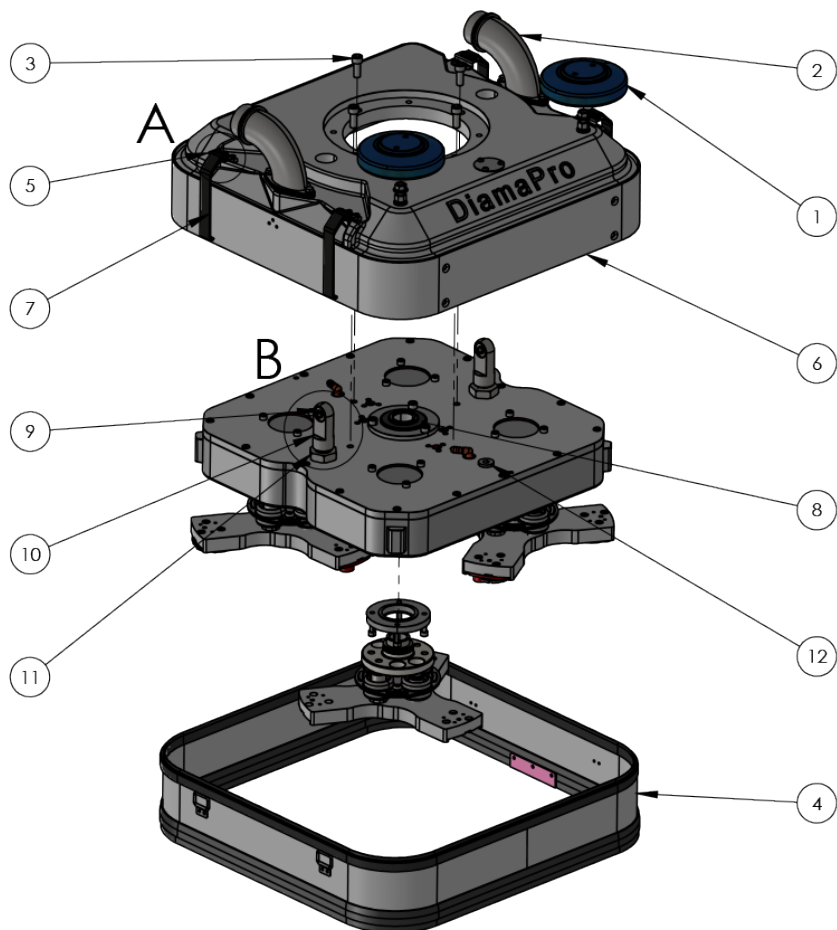

DETAIL A

SCALE 1 : 2

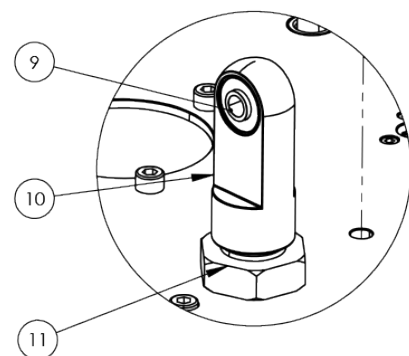

DETAIL B

SCALE 1 : 3

NOTE: See next page for Grinding Plate Assembly

ITEM NO.	PART NUMBER	DESCRIPTION	QTY.
TOP COVER			
1	DP-DX26-WGHT	FRONT COUNTER WEIGHT	2
2	DP-DX26-VCPP	VACUUM PIPE (1 LEFT 1 RIGHT)	2
3	DP-GH-DX0267	HEXAGON SOCKET BOLT M10x30	4
4	DP-DX26-MTDC	DUST COVER/SHROUD	1
5	DP-DX26-DPBS	DUST PLUG BASE	4
6	DP-DX26-GBCV	GEARBOX COVER	1
7	DP-DX26-DTLG	DUST COVER STRAP	4
NP	DP-DX26-RBDC	RUBBER DUST COVER	1
BOTTOM COVER			
8	DP-OSEAL-55X80X8	OIL SEAL 55x80x8	2
9	DP-DX26-LLBB	LIFT LUG BUFFER BUSHING	2
10	DP-DX26-TUNN	TRUNNION	2
11	DP-DX26-LFTT	LIFTING TRUNNION POSITIONING NUT	2
12	DP-DX26-EXHV	TRANSMISSION EXHAUST VALVE	1

TOOL PLATE ASSEMBLY

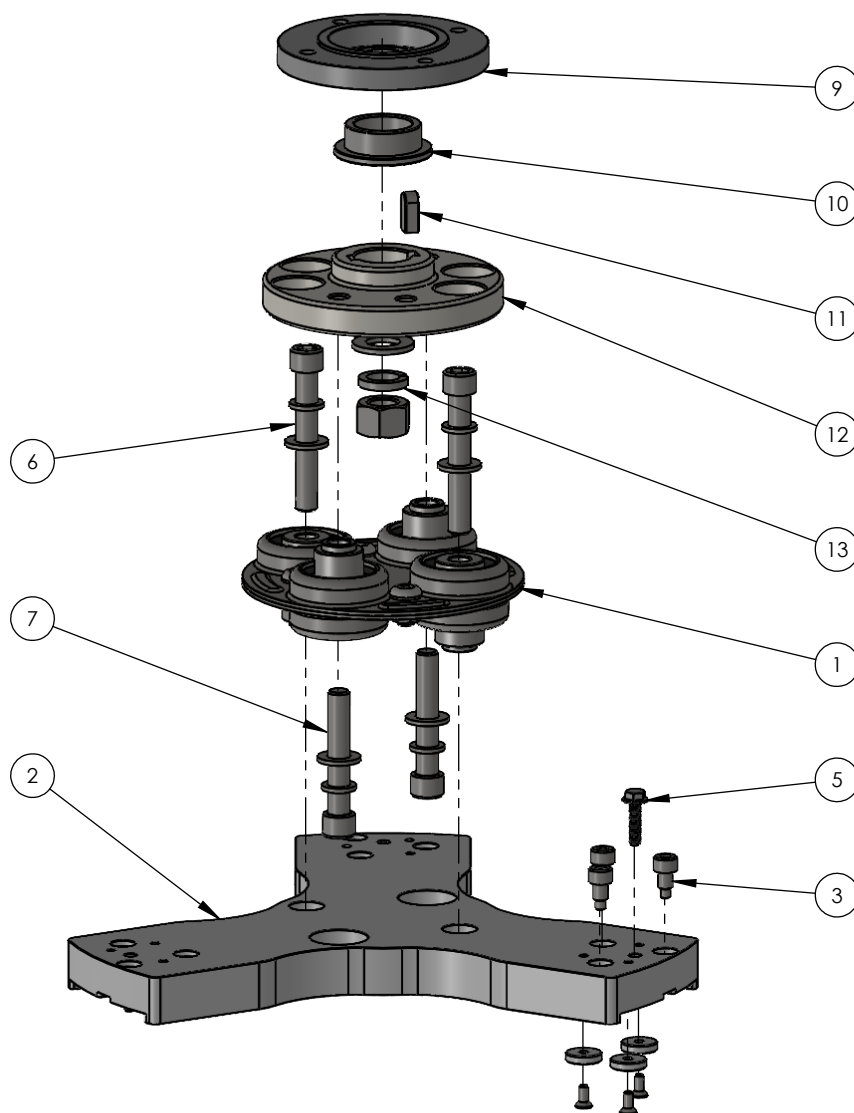

ITEM NO.	PART NUMBER	DESCRIPTION	QTY.
1	DP-GH-FLCO	FLEX COUPLER	4
2	DP-DX26-GRPL-STEEL	GRINDING PLATE, STEEL *PLEASE NOTE; ONLY DP-GH-RTSY-18 WILL WORK WITH STEEL PLATES.	4
3	DP-GH-DXTP	M8 TOOL RETENTION PIN	36
4	DP-GH-RTSY	FLANGE HEAD SECURITY BOLT M6 x 27mm (FOR ALUMINUM TP)	12
5	DP-GH-RTSY-18	FLANGE HEAD SECURITY BOLT M6 x 18mm (FOR STEEL TP)	12
6	DP-GH-DX0115	HEXAGON SOCKET BOLT M12X80 + SPRING WASHER + FLAT WASHER	8
7	DP-GH-DX0116	HEXAGON SOCKET BOLT M12X70 + SPRING WASHER + FLAT WASHER	8
8	DP-DX26-GRPL	GRINDING PLATE, ALUMINUM (OPTIONAL) *PLEASE NOTE; ONLY DP-GH-RTSY WILL WORK WITH ALUMINUM PLATES.	
9	DP-BEAR-6207-LOWER	LOWER BEARING BASE ASSEMBLY 6207	4
10	DP-DX26-SLSR	SEALING STEEL RING	4
11	DP-KEY-10X8X22	SHEAR KEY 10x8x22	4
12	DP-DX26-GRCB	GRINDING CLAW BASE	4
13	DP-DX26-GRCB-HW	NUT M18 + SPRING WASHER + FLAT WASHER	4

GEAR SHAFT ASSEMBLY

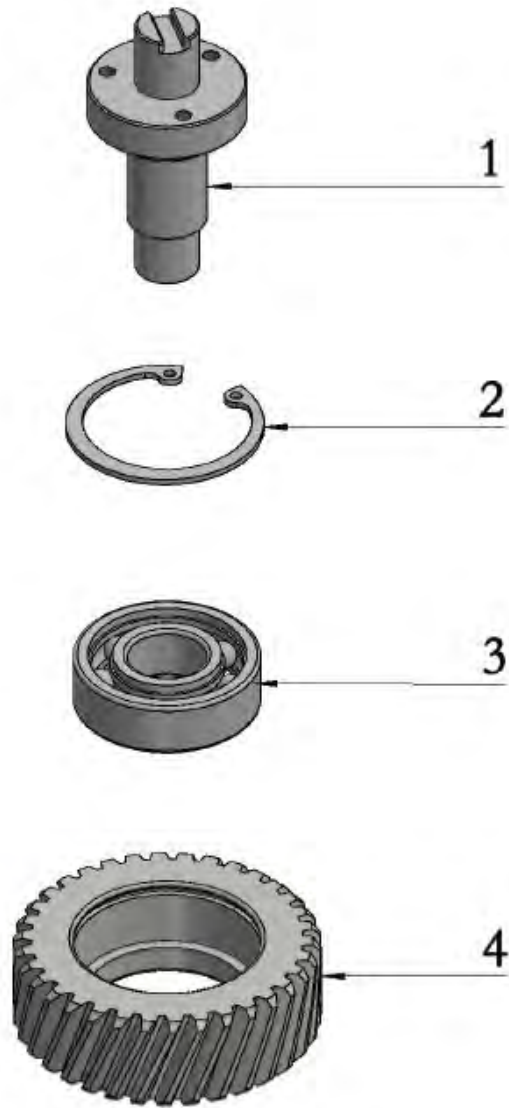

ITEM NO.	PART NUMBER	DESCRIPTION	QTY.
1	DP-DX26-TNSF	TRANSITION SHAFT	4
2	DP-DX26-CN47	CIRCLIP 47MM	4
3	DP-BEAR-6204	BEARING 6204	4
4	DP-DX26-TRNG	TRANSITION GEAR	4

SUPPLEMENTAL ENGINE PARTS

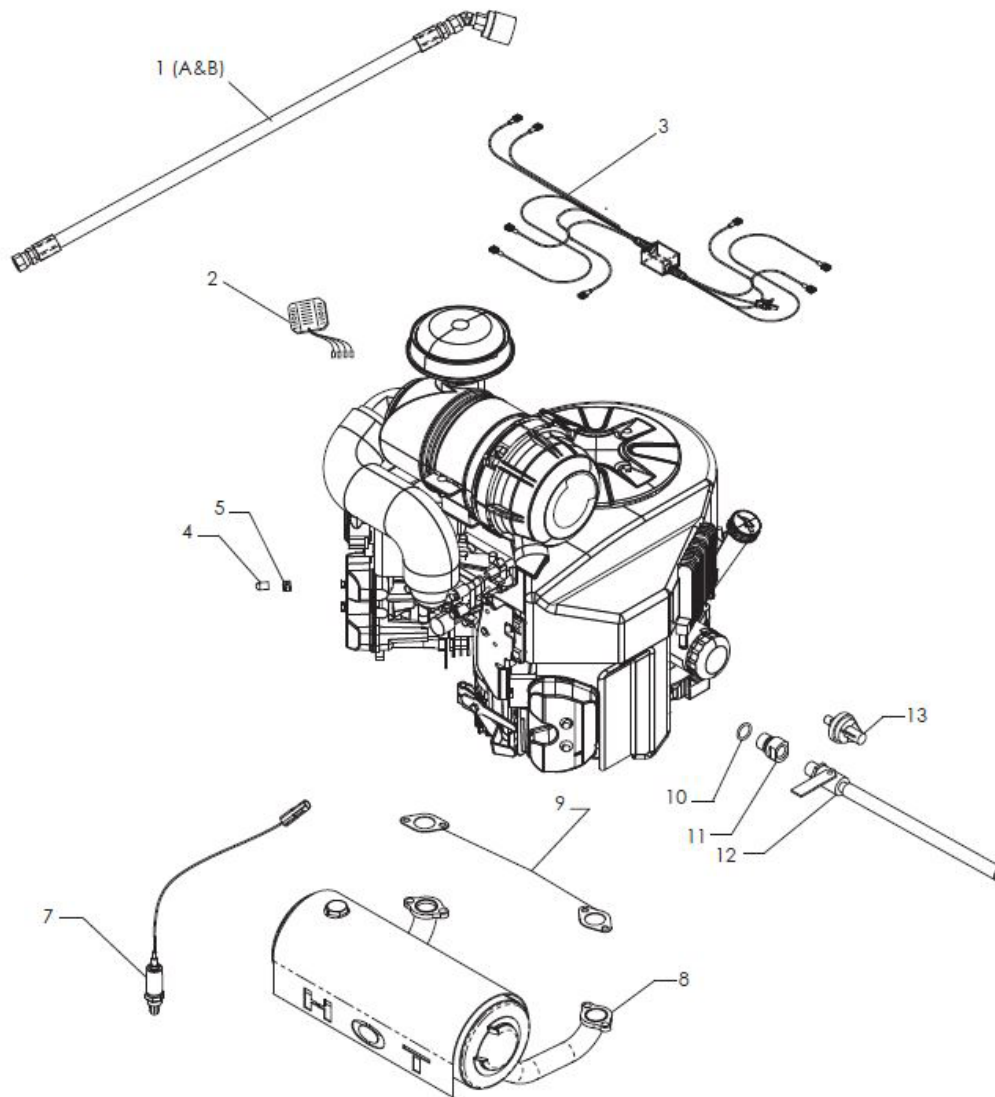

ITEM NO.	PART NUMBER	DESCRIPTION	QTY.
1A	DP-GH-KAW1-A	ASM-60IN HIGH PRES. HOSE ASM RH	1
1B	DP-GH-KAW-1B	ASM-HIGH PRES. LP HOSE ASM-48IN., RH THREAD	1
2	DP-GH-KAW2	VOLTAGE REGULATOR - AC TO 12VDC, 22 AMP	1
3	DP-GH-KAW3	WIRING HARNESS-UNIVERSAL HOT START W/ DPDT RELAY	1
4	DP-GH-KAW4	VACUUM CAP-RUBBER, 1/4IN. ID X 9/16IN. L.	1
5	DP-GH-KAW5	SPRING CLAMP - 7/16IN.	1
7	DP-GH-KAW7	O2 SENSOR, EXHAUST, NARROW BAND	1
8	DP-GH-KAW8	CATALYST MUFFLER, 852CC	1
9	DP-GH-KAW9	EXHAUST GASKET 603CC & 852CC	2
10	DP-GH-KAW10	O RING, 16MM	1
11	DP-GH-KAW11	JOINT, OIL DRAIN	1
12	DP-GH-KAW12	OIL DRAIN ASM, 3.8 NPT	1
13	DP-GH-KAW13	OIL PRESSURE SWITCH, SPST, N.O., 1/8 BSP	1

ENGINE PARTS (NOT PICTURED)

PART NUMBER	DESCRIPTION	QTY.
DP-SPLG-7003	SPARK PLUG MODEL(S) DX26-P, RCJ8Y SPARK PLUG 17HP	2
DP-FOIL-7010	OIL FILTER MODEL(S) DX26-P	2
DP-FAIR-7020	AIR FILTER KAWA 28 (OUTER) MODEL(S) DX26-P	1
DP-FAIR-7019	AIR FILTER KAWA 28 (INNER) MODEL(S) DX26-P	1
DP-DX26-REGR	T60 REGULATOR W/ PLUGS, B ORIENT. MODEL(S) DX26-P	1
DP-DX-SOLE	PROPANE SOLENOID SHUTOFF VALVE "LOCKOFF", 12V, BRASS, 1/4 NPT MODEL(S) DX26-P	1
DP-DX26-AMFT	LPG AUTOMOTIVE FILTER - 3/8 MALE FLARE X 1/4 MNPT MODEL(S) DX26-P	1

CONTROL PANEL ASSEMBLY

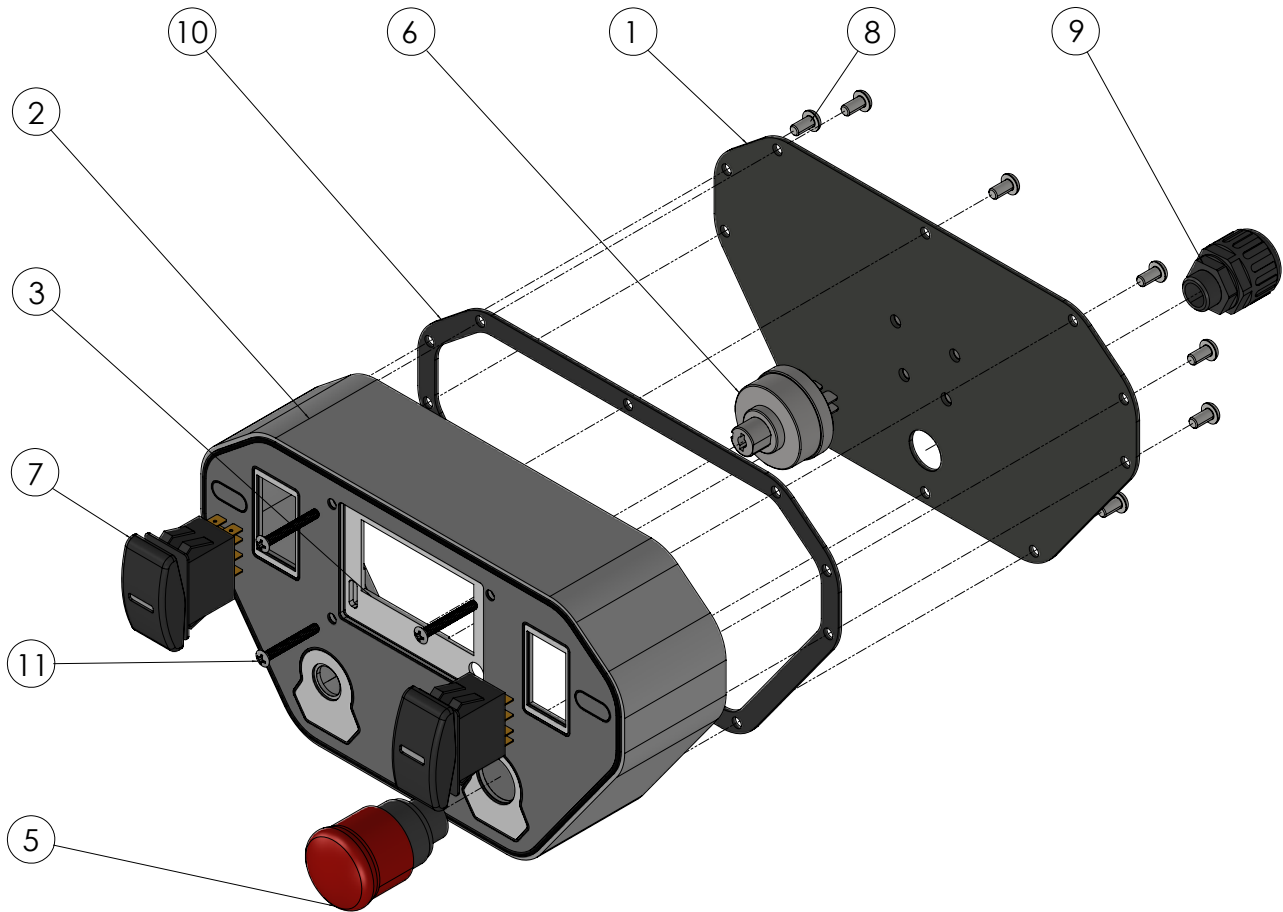

ITEM NO.	PART NUMBER	DESCRIPTION	QTY.
1	DP-DX-CPBP	CONTROL PANEL BACK PLATE	1
2	DP-DX-CPEN	CONTROL PANEL ENCLOSURE	1
3	DP-EMS-H	SAM UNIT	1
4	DP-DX26-P-PTC	THROTTLE CABLE ASSEMBLY (NOT PICTURED)	1
5	DP-DX-ESSW	E-STOP SWITCH	1
6	DP-DX-ISWK	IGNITION/KEY SWITCH	1
7	DP-DX-2PSW	2-POSITION SWITCH (CLUTCH & LED SWITCH)	2
8	DP-GH-DX0155	M5 X 10 BUTTON HEAD HEX BOLT	10
9	DP-GH-DX0297	STRAIN RELIEF	1
10	DP-DX-CPGS	CONTROL PANEL GASKET	1
11	DP-GH-832SW	SAM UNIT SCREWS	4

Customer Acknowledgment and Assumption of Responsibility for Modification to any Product.

Customer expressly acknowledges that modification of any equipment, machines, or other products purchased from Niagara Machine, Inc. ("Niagara"), including but not limited to DiamaPro Systems Products (collectively, "Products") through the attempted or actual use or misuse, adjustment, alteration, application of additional components, removal of provided components, repairs or attempted repairs by Customer (collectively, "Modifications") can lead to Product malfunction causing serious risks. Such risks include, but are not limited to, Product damage, bodily injury, death, or loss of or damage to property. Customer agrees that Customer is solely responsible for any Modifications Customer performs on any Product purchased from Niagara, and that Niagara is not responsible and will not be held liable for any claims, damages, or injury arising from Modifications by Customer, including Customer's employees, subcontractors, agents, representatives, affiliates, and assigns, to any Product purchased from Niagara. Customer further acknowledges and agrees that any Modification(s) to a Product may, at DiamaPro Systems' and/or Niagara's election, void any warranty applicable to the Product.

Customer agrees that, to the greatest extent permitted by law, Customer shall indemnify, hold harmless and, at Niagara's request, defend (with counsel reasonably approved by Niagara), Niagara, Niagara's parent, subsidiaries, affiliates and the officers, directors, employees and agents of Niagara (individually and collectively "Niagara Indemnitees") from and against, and pay or reimburse them for any and all third-party claims, losses, damages, liabilities, lawsuits and expenses (including reasonable attorneys' fees) relating to bodily injury, death, or loss of or damage to property caused by or arising from any Modification to a Product by Customer, its employees, subcontractors, agents, representatives, affiliates, and assigns (individually and collectively, "Customer Group"), with respect to the Products Customer purchases from Niagara.

Customer acknowledges that Customer has read and understands these terms, and voluntarily assumes full and sole responsibility for any and all effects arising from any Modification to a Product by Customer Group.



DiamaPro®

SYSTEMS

DiamaPro® Systems
3343 Peachtree Road NE
Suite 145 #24
Atlanta, GA 30326
470-977-2323