



Diamapro[®]
SYSTEMS

OWNER'S MANUAL

SVX3+A

INDUSTRIAL VACUUM



USER & MAINTENANCE BOOK

SAVE THESE INSTRUCTIONS FOR FUTURE REFERENCE



WARRANTY REGISTRATION CARD

Form must be completed and submitted within 30 days from the date of purchase.

Customer Information

First and Last Name

Company Name

Address

City

State

Zip Code

Phone Number

Email

Machine Information

Machine Type

Machine Model

Serial #

Purchase Date (dd/mm/yy)

Diamapro Systems®
3343 Peachtree Road NE
Suite 145 #24
Atlanta, GA 30326

1. INTRODUCTION

Thank you for purchasing a DIAMAPRO® SYSTEMS product. This manual provides information and procedures to safely operate and maintain the DiamaPro® SVX3+A. For your own safety and protection from injury, carefully read, understand, and observe the safety instructions described in this manual. Keep this manual or a copy of it with the machine. If you lose this manual or need an additional copy, please contact DiamaPro® Systems. This machine is designed and built with user safety in mind; however, it can present hazards if improperly operated and serviced. Please follow the operating instructions carefully. If there are any questions regarding operating or servicing of this machine, please contact DiamaPro® Systems.

Disclaimer: DiamaPro® Systems and its affiliates take no responsibility for any damage, injury or death resulting from the incorrect or unsafe use of this product. Use of this product should be undertaken by competent persons only. It is the operator's responsibility to ensure that the following safety procedures are followed. If you are unsure, do not operate this product.



IT IS NECESSARY THAT THE AUTHORIZED PERSONNEL AND MACHINE OPERATOR HAVE READ AND UNDERSTOOD THE MANUAL BEFORE USING THE MACHINE.

2. WARRANTY

DiamaPro® SVX model vacuums are warranted to be free from manufacturing defects in normal service for a period of one or two years from the date of purchase by the original consumer purchaser. Component manufacturers offer separate warranty periods. Call 470-977-2323 for complete information.

DiamaPro® System's obligation under this warranty is expressly limited to the replacement of such part or parts as inspection shall disclose to have been defective.

This warranty does not apply to defects caused by damage, unreasonable use, faulty repairs made by others or defects caused by failure to provide reasonable maintenance.

Further, the warranty is void if the product, or any of its components, is altered or modified by the consumer or if the product is used in an inappropriate manner or with equipment not recommended by the manufacturer.

Wear items are not covered under warranty: examples include: belts, wheels, casters, bearings, cart wheels, filters, wear pads, spark plugs, hoses, wands and squeegees, motors, etc.

To qualify for warranty coverage, DiamaPro® SVX vacuums must be registered within 30 days of purchase. Registration can be completed online at www.DiamaProSystems.com.

To request your warranty service you MUST send a written request to:

*DiamaPro® Systems
P.O. Box 19946
Charlotte, NC, 28219*

including the manufacturing details that can be found on a plate fitted inside your machine together with a copy of the invoice.

The warranty is invalid under the following conditions:

- Improper use of the machine or total or partial failure to comply with the contents of this manual
- Any part of the vacuum cleaner is altered or modified in any way
- Incorrect electrical installation
- If the laws in the country of use are not respected
- Inadequate maintenance
- The machine has not undergone routine maintenance as specified in this manual
- Use of spare parts that are not produced by DiamaPro® or not specifically indicated for the model in use
- Partial or total failure to comply with the instructions given in this manual

3. UNINTENDED USE

- Do not use the machine for sucking up liquid material
- Do not use the machine or expose the machine to water, rain, or rain like environments
- Do not use the machine with improper extension cords or extension cords of improper length

4. MACHINE DATA

4.1 TECHNICAL DATA PLATE

Every DiamaPro® machine carries a registration plate showing essential details that are necessary when contacting the supplier/manufacturer for advice, suggestions or information on spare parts. The following details are included on the plate:

- Manufacturer
- Model
- Supply voltage
- Installed rated power
- CE symbol (built in compliance with Machinery Directive 2006/42/EEC)

4.2 SAFETY DEVICE

The vacuum cleaner has been manufactured in compliance with all legal standards for the operator's safety.

- All metal components are grounded to eliminate shock or electrostatic discharge, including the flexible suction hose that is properly grounded. Also in this regard the choice of a suitable flexible suction hose allows to eliminate this risk on the hose length that goes from the use area to the vacuum cleaner.
- The brakes fitted onto the anterior pivoting casters safely fix the machine in its place of use where there may be a risk of movement due to uneven floor surfaces or other particular working conditions.



BEFORE USING THE MACHINE CHECK THAT THE MACHINE HAS NOT SUFFERED ANY SHOCKS OR DAMAGES DURING THE TRANSPORT THAT CAN AFFECT THE OPERATION OF THE ABOVE DEVICES

5. PERFORMANCE TOLERANCES

The performance of the machine may vary based upon environmental factors such as temperature, air pressure, humidity, etc.

CALIFORNIA PROP 65 WARNING

Thank you for purchasing a DIAMAPRO® SYSTEMS product. This manual provides information and procedures to safely operate and maintain the DiamoPro® SVX3+A. For your own safety and protection from injury, carefully read, understand, and observe the safety instructions described in this manual. Keep this manual or a copy of it with the machine. If you lose this manual or need an additional copy, please contact DiamoPro® Systems. This machine is designed and built with user safety in mind; however, it can present hazards if improperly operated and serviced. Please follow the operating instructions carefully. If there are any questions regarding operating or servicing of this machine, please contact DiamoPro® Systems.



THIS PRODUCT CONTAINS LEAD, A CHEMICAL KNOWN TO THE STATE OF CALIFORNIA TO CAUSE BIRTH DEFECTS OR OTHER REPRODUCTIVE HARM.



THIS PRODUCT CONTAINS ONE OR MORE CHEMICALS KNOWN TO THE STATE OF CALIFORNIA TO CAUSE CANCER, BIRTH DEFECTS OR OTHER REPRODUCTIVE HARM.



EXHAUST GASES FROM THIS PRODUCT CONTAIN CHEMICALS KNOWN TO THE STATE OF CALIFORNIA TO CAUSE CANCER, BIRTH DEFECTS OR OTHER REPRODUCTIVE HARM.

DUST WARNING

Cutting, especially when DRY cutting, generates dust that comes from the material being cut, which frequently contains silica.

When dry cutting, be sure to use a HEPA filtered dust collector. Silica is a basic component of sand, quartz, brick clay, granite and numerous other minerals and rocks. Exposure to excessive amount of such dust can cause:

- Respiratory diseases (affecting your ability to breath), including chronic bronchitis, silicosis and pulmonary fibrosis from exposure to silica. These diseases may be fatal;
- Skin irritation and rash; and
- Cancer according to NTP* and IARC*
*National Toxicology Program, International Agency for Research on Cancer

Take precautionary steps

- Avoid inhalation of and skin contact with dust, mist and fumes;
- Wet cut when feasible, to minimize dust;
- Wear and ensure that all bystanders wear appropriate respiratory protection such as dust masks designed to filter out microscopic particles. (See OSHA 29 CFR Part 1910.1200)

CALIFORNIA PROP 65 WARNING

Use of this product can cause exposure to materials known to the State of California to cause cancer and/or birth defects or other reproductive harm.

6. SAFETY PROVISIONS

- Carefully read the instructions in this manual before starting, using, servicing or operating the vacuum cleaner
- Check that the vacuum cleaner hasn't been damaged in any way
- Never turn on the machine if it is faulty or if you suspect it is faulty
- Check that the switch isn't worn or damaged
- Do not approach the suction intake of the machine with unfastened or broken garments that could easily be sucked into the machine
- Check that the filters are present and efficient
- Make sure that the filters are installed correctly and in full working order, always observing the regulations in force in the workplace
- Do not carry out repairs without the manufacturer's authorization
- Never use gasoline, solvents or other flammable liquids for cleaning; only proper detergents should be used for cleaning
- Never move the machine by pulling the power cable or flexible hose
- Never direct the opening of the machine or the flexible tube towards people or animals
- Protect the machine from the rain
- Check that the machine is connected to a power source with the correct voltage indicated on the registration plate
- Make sure that the power cable has no wear or damage. If replacing the cable, always replace it with another of the same specifications as the original one: cables that are not approved or of inferior quality may overheat and cause serious injury to the user
- Make sure that the machine is connected to an appropriate power source in full working order (check the presence of a fully functional grounding socket)
- Repairs must only be carried out by authorized personnel and only when the machine is turned off and disconnected from the power source
- Never allow unauthorized personnel to use the machine
- Make sure that all safety devices are in full working order before turning on the machine
- Never cover the vacuum cleaner during use

7. INSTALLATION

7.1 DELIVERY AND HANDLING

All machines are carefully tested and checked by DiamoPro before delivery. The machine is transported inside a protective box or wrapped in a protective film that allows the courier to see the item during transport and is securely fixed to a pallet. If any part of the machine is not intact or has been damaged during transport, file an immediate complaint with the courier. Parts that have been damaged or broken due to incorrect transport or handling of the machine will not be recognized by the manufacturer's warranty. The machine must be lifted and moved using a forklift truck in accordance with the relevant safety regulations in force in the workplace

7.2 CHECK THE PROPER ELECTRICAL CONNECTION

Connect the industrial plug to the power cable and connect the plug to a socket that has the same amp rating and is protected by a line-isolating switch.

8. PERIODICAL MAINTENANCE

Maintenance and cleaning operations must ALWAYS be carried out when the vacuum is turned off and disconnected from the power source. No particular measures must be taken for the maintenance, cleaning or lubrication of the suction unit. However, it is important to remember that correct use and servicing are essential if the safety and efficiency of the vacuum are to be guaranteed.

To ensure regular and constant operation and to prevent the warranty from becoming void, always use genuine DiamoPro spare parts when repairs are needed.

8.1 BEFORE TURNING ON AND TURNING OFF EVERY DAY

- Visually check that the suction hose has not been damaged in any way (it must not be damaged, torn, crushed)
- Check that the electrical switches are in full working order and are not damaged in any way
- Check the level of waste inside the main barrel N.B. Empty the main barrel if you are using an DiamoPro model empty the main barrel
- Check that the suction hose has not been damaged in any way
- Check that the motor head is correctly positioned on the filter chamber and that the latter is correctly placed on the main barrel
- If the vacuum cleaner is moved, ensure that the power voltage of the play in this new location corresponds to the one on the technical data plate

8.2 AT EVERY 50 HOURS OF OPERATION

- Check the condition of the primary filter: it must not have tears, holes or other damage: in this case replace it (see 14.)
- Check that the technical data plate is legible and not damaged in any way: contact the manufacturer for a replacement if necessary

9. PRODUCT DISPOSAL

Dispose of the machine and any accessories according to the legislation of the state/country. To avoid affecting the environment or your health or the health of others it is recommended to separate the machine from other waste, and if necessary properly recycle it.

10. DESCRIPTION



1. SUCTION UNIT
2. ON-OFF SWITCH
3. AUTO FILTER PURGE FREQUENCY DIAL
4. CHECK FILTER INDICATOR LIGHT
5. FORCED FILTER PURGE BUTTON
6. ACCESSORIES CONNECTION
7. WHEELS WITH BRAKE
8. INFINITY BAG

11. USING THE VACUUM CLEANER



Before switching ON the vacuum be sure the container is empty

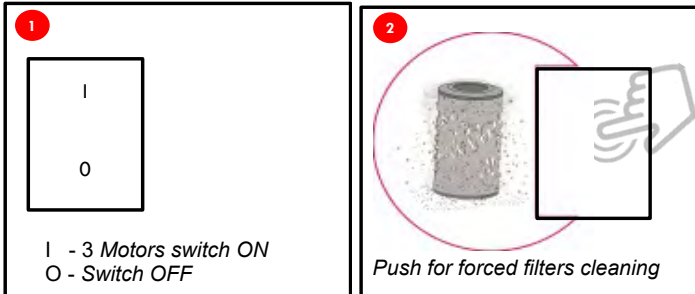

I - 3 Motors switch ON
O - Switch OFF

Push for forced filters cleaning

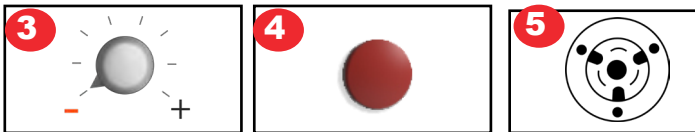

Adjust Dial for Filter Purge Interval

Check Filter Indicator Light

Socket (220V ONLY)

12. FILTER REPLACEMENT

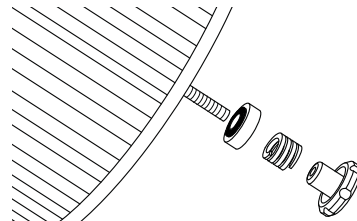
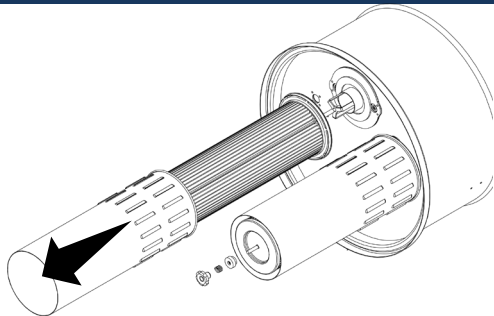

1. Disconnect and lift the head.
2. Remove the filter's cylindrical steel protection (unscrewing the screws on the edge)
3. Unscrew the wing nut and remove the spring and washer
4. Replace the filter with a proper one for the vacuum cleaner in use
5. Install the new filter according to the label on the bottom of the filter
 - Washer with rubber part facing the base of the filter
 - Spring
 - Plastic wing nut
6. Mount the cylindrical protection, then reconnect the head on the filtering chamber

13. MOUNTING OF PARTS

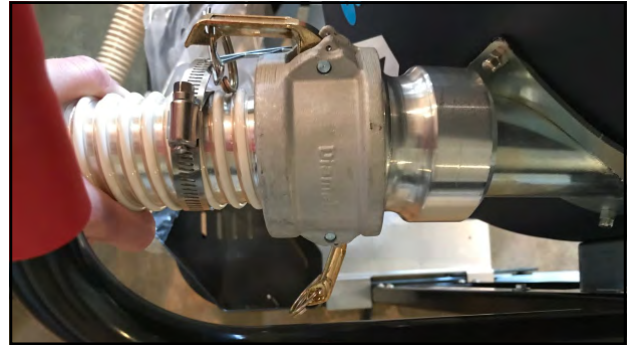

Connect one end of the flexible hose to desired accessory and the other with the camlock mounted on the filter chamber. (Sew accessories pg.)

14. COLLECTION BAG USE

The dust and the particles are collected in a bag placed in the container under the hopper.

The Infinity Bag system consists in a plastic tubular from which are obtained 20/30 bags of different weights and dimensions. Once finished or damaged, the tubular must be replaced by a new refill. The operations below described must be carried out when machine is turned off.



1 - Close the bag with two distanced bands.



2 - Cut the strip between the two bands.



3 - Pull the Infinity Bag end to make a new bag.

15. BAG REPLACEMENT



1- Cut the Infinity Bag in order to let it open.



2- Pull and rotate the retaining pins of the Infinity bag container in order to unfasten them.

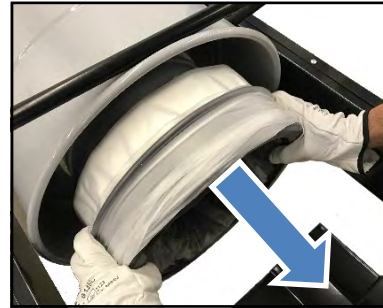

3- Remove the Infinity Bag container and any waste.



4- Insert the new Infinity Bag with the inner part facing upwards.



5- Cut and remove the Infinity Bag closing bands.



6- Keep the inner part of the bag inside the container and pull it up to the lower edge.



7- Pull the outer part of the bag to create a new one.

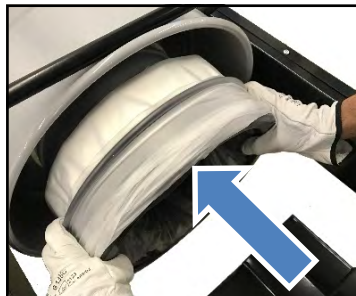

8- Insert the container with the Infinity Bag.



9- Pull and rotate the retaining pins and insert them into their seats.



10- Pull the bag and place at the edge the band to create a new one. If necessary use two bands.

16. TROUBLESHOOTING

To help solve any problem that may occur

Motors do not start.

- ▶ No electrical voltage.
- ▶ Check cables, plugs and socket.

Suction capacity decreases slowly.

- ▶ Filter, nozzle, suction hose or suction pipe may be blocked.
- ▶ Check, clean accessories. Clean filter.

Dust comes out during the vacuuming.

- ▶ Filter has not been fastened correctly or is defective.
- ▶ Check to see if filter is sitting properly; replace if required.

17. ELECTRICAL DIAGRAMS

SVX3+A 110V WIRING DIAGRAM

No.	Part No.
1	SVX-RTBSK
2	SVX-LED+
3	SVX-SWITCH ON/OFF
4	SVX-SWITCH-PURGE
5	SVX-BOARD-110V
6	SVX-MOTOR-110V
7	SVX-SHAKER-120V
8	SVX-DIODE
9	SVX-DIAL+
10	SVX-HOURMETER+
11	SVX-POTENTIOMETER+

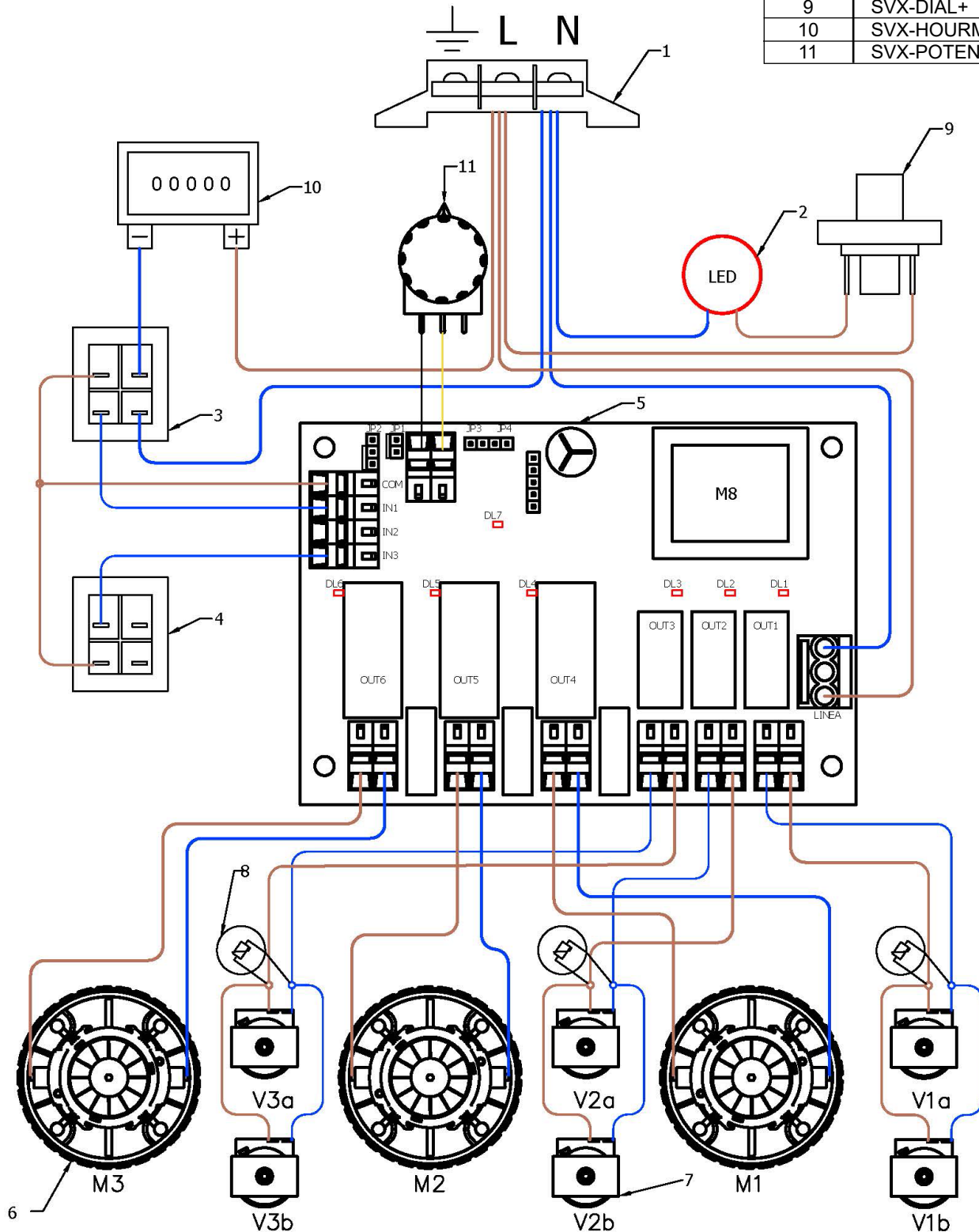

17. ELECTRICAL DIAGRAMS

SVX3-A 220V WIRING DIAGRAM

No.	Part No.
1	SVX-RTBSK
3	SVX-SWITCH ON/OFF
4	SVX-SWITCH-PURGE
5	SVX-BOARD-230V
6	SVX-MOTOR-230V
7	SVX-SHAKER-230V
8	SVX-DIODE
9	SVX-DIAL+
10	SVX-HOURMETER+
11	SVX-POTENTIOMETER+
12	SVX-LED+
13	SVX-PLUG-220

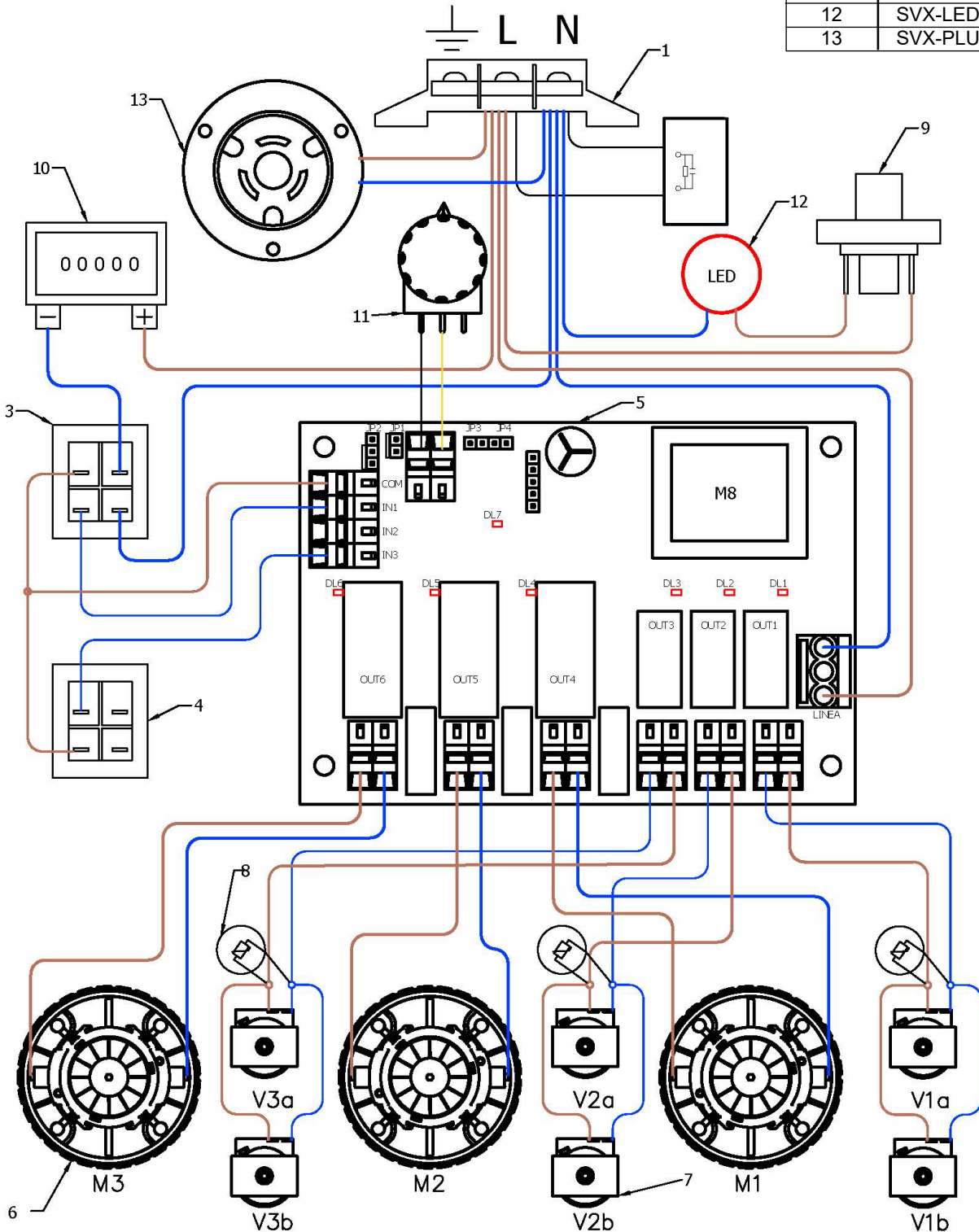

18. UNIT OVERVIEW - 110V

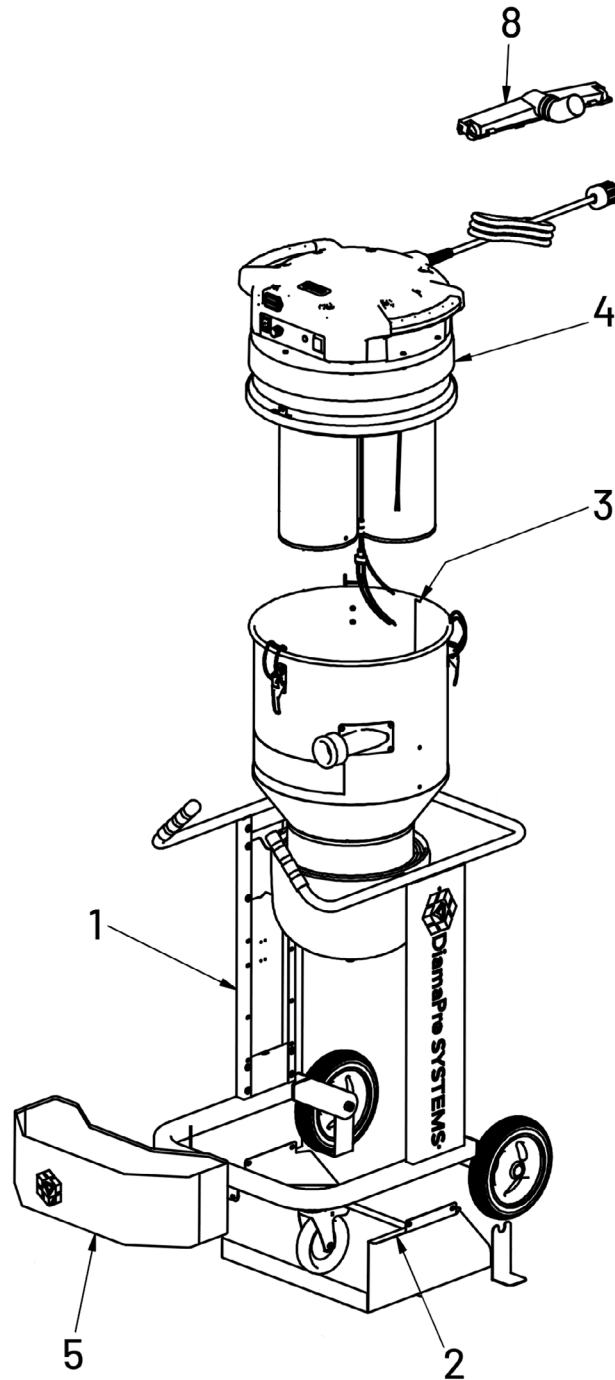

ITEM NO.	PART NUMBER	DESCRIPTION	QTY.
1	SVX-SIDEFRA-ME-A	SIDE FRAME (AUTOMATIC MODELS ONLY)	1
2	SVX-BAGHOLDER-3A	INFINITY BAG BASE FOR 3A(+) UNITS	1
3	SVX-HOPPER-3A	BLUE HOPPER FOR SVX3A(+)	1
4	SVX3A+TOPASSEMBLY	SVX3+A TOP ASSEMBLY	1
5	SVX-TROLLEY-3A	TROLLEY FOR SVX3A	1
8	SVX-FLOOR-TOOL-2	WET/DRY PLASTIC FLOOR TOOL	1

19. TOP ASSEMBLY - 110V

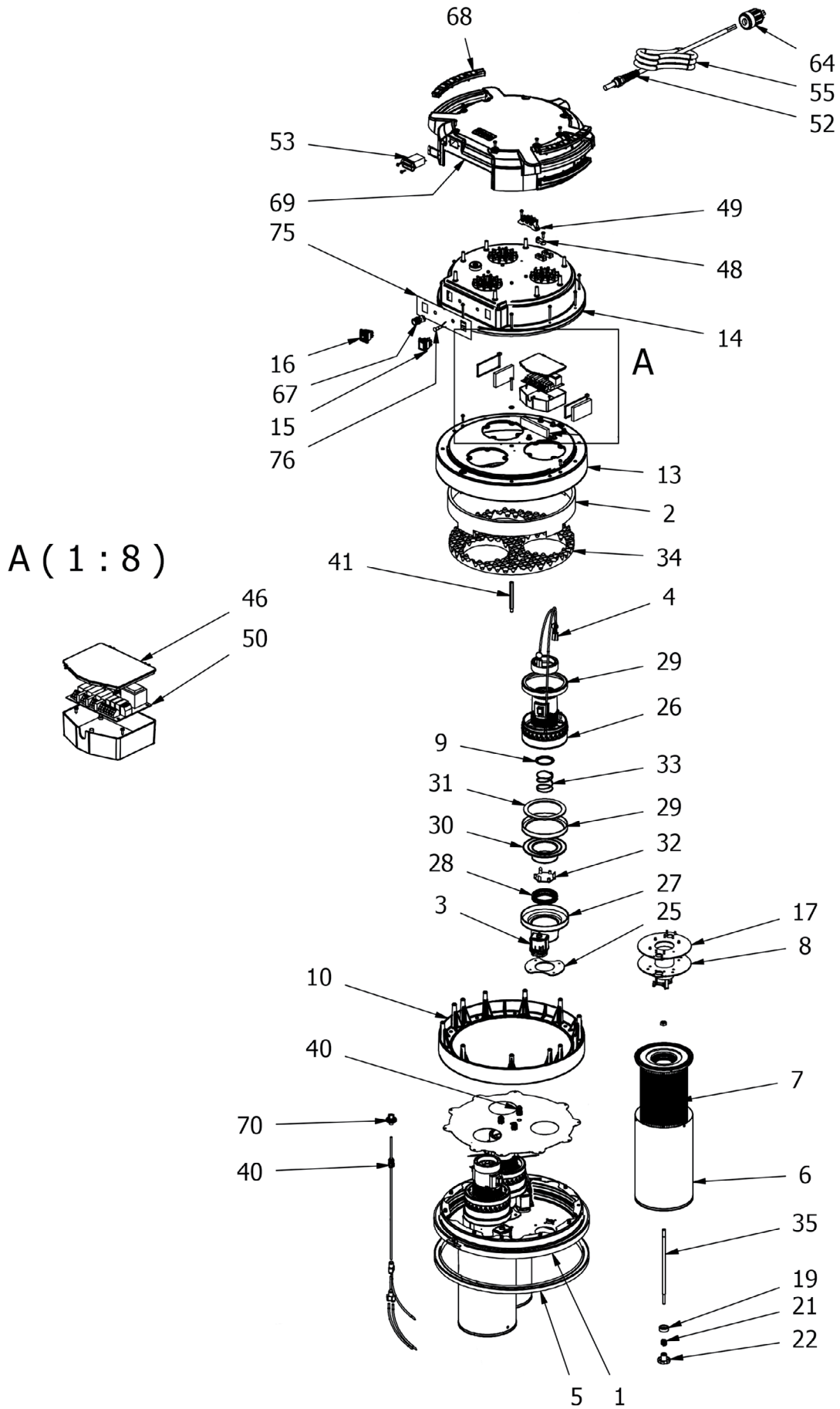

19. TOP ASSEMBLY - 110V

ITEM NO.	PART NUMBER	DESCRIPTION	QTY.
1	SVX-BC3M	BASE COVER SVX3A	1
2	SVX-SPRS	SOUND PROOFING RING STRIP	1
3	SVX-SHAKER-120V	SHAKER 120V 60HZ	6
4	SVX-SHAKER-POWER-CABLE	SHAKER POWER CABLE	3
5	SVX-GASKET3A-460	SUCTION HEAD GASKET FOR SVX3A & TVX MODELS	1
6	SVX-FIL-PROTECTION	FILTER HOUSING FOR 3A(+)	3
7	SVX-3A+HEPA	SVX3A+ HEPA FILTER	3
8	SVX-SUCT-MANI-CLEAN	SUCTION MANIFOLD ICLEAN	3
9	SVX-RING-FITTING-A	RING FITTING (FOR AUTOMATIC MODELS ONLY)	3
10	SVX-FOAMHOLDER-3A	FOAM HOLDER (SVX3A ONLY)	1
13	SVX-MR3A	MOTOR RETAINER (BOTTOM) SVX3A	1
14	SVX-HC3A	HEAD COVER (MIDDLE)	1
15	SVX-SWITCH-PURGE	PURGE SWITCH (FOR AUTOMATIC MODELS ONLY)	1
16	SVX-SWITCH-ON/OFF	16 AMP SWITCH WITH CUFFS (1 FOR AUTOMATIC UNIT)	1
17	SVX-SUCT-MANI-GASKET	SUCTION MANIFOLD GASKET	3
19	SVX-ZPSRS-A	ZINC PLATED SEALING RING	3
21	SVX-FIL-PRESS-SPRING	FILTER PRESSURE SPRING	3
22	SVX-KNOB-STOPPER	PLASTIC KNOB FILTER STOPPER	3
25	SVX-SM-FLANGE	SUCTION MANIFOLD FLANGE	3
26	SVX-MOTOR-110V	MOTOR 110V	3
27	SVX-MHOLDER-AUTO	MOTOR HOLDER (AUTOMATIC MODELS ONLY)	3
28	SVX-CABLE-BUSHING	CABLE BUSHING	3
29	SVX-GASKET	GASKET	6
30	SVX-MVH	MOTOR VALVE HOLDER	3
31	SVX-SW-135X109X4	VALVE HOLDER SPONGE	3
32	SVX-VM-BYPASS	VALVE MOTOR BYPASS	3
33	SVX-VAL-SPRING	VALVE SPRING	3
34	SVX-SPS3A	SOUND PROOFING SPONGE (FOR SVX3A)	1
35	SVX-HOLDER-3A-HEPA	FILTER SHAFT HOLDER 3A(+)	3
40	SVX-CABLEGLAND-PG7	CABLE GLAND WITH TIGHTENING NUT AUTOMATIC ONLY	4
41	SVX-M8X95	CENTAL SPACER	1
46	SVX-MOTHERBOARD-HOUSING	PLASTIC MOTHERBOARD HOUSING FOR AUTOMATIC UNITS.	1
48	SVX-CABLE-STOPPER	CABLE STOPPER (ALL MODELS)	1
49	SVX-RTBSK	RED TERMINAL BLOCK WITH SCREW	1
50	SVX-BOARD-110V	MOTHERBOARD (AUTOMATIC MODELS ONLY)	1
52	SVX-CABLEGLAND-110V	CABLE GLAND FOR 110V AUTOMATIC UNITS	1
53	SVX-HOUR-METER	HOUR METER FOR SVX UNITS	1
55	SVX-CABLE-3GX6	CABLE *110 Machines*	1
64	SVX-PLUGEND	20AMP PLUG - END OF CORD	1
67	SVX-POTENTIOMETER+	COMPLETE POTENTIOMETER	1
68	SVX-RED-HANDLE+	RED HANDLE PLUS MODELS	4
69	SVX-3A-UPPERCOVER+	UPPER COVER 3 MOTORS WITH HANDLES	1
70	SVX-DIAL+	DEPRESSION SWITCH	1
75	SVX-3A-FRONT-PANEL+	FRONT PANEL STICKER FOR SVX3+A	1
76	SVX-LED+	RED LED LIGHT	1

20. TOP ASSEMBLY - 220V

SVX3A-220V
Top Assembly

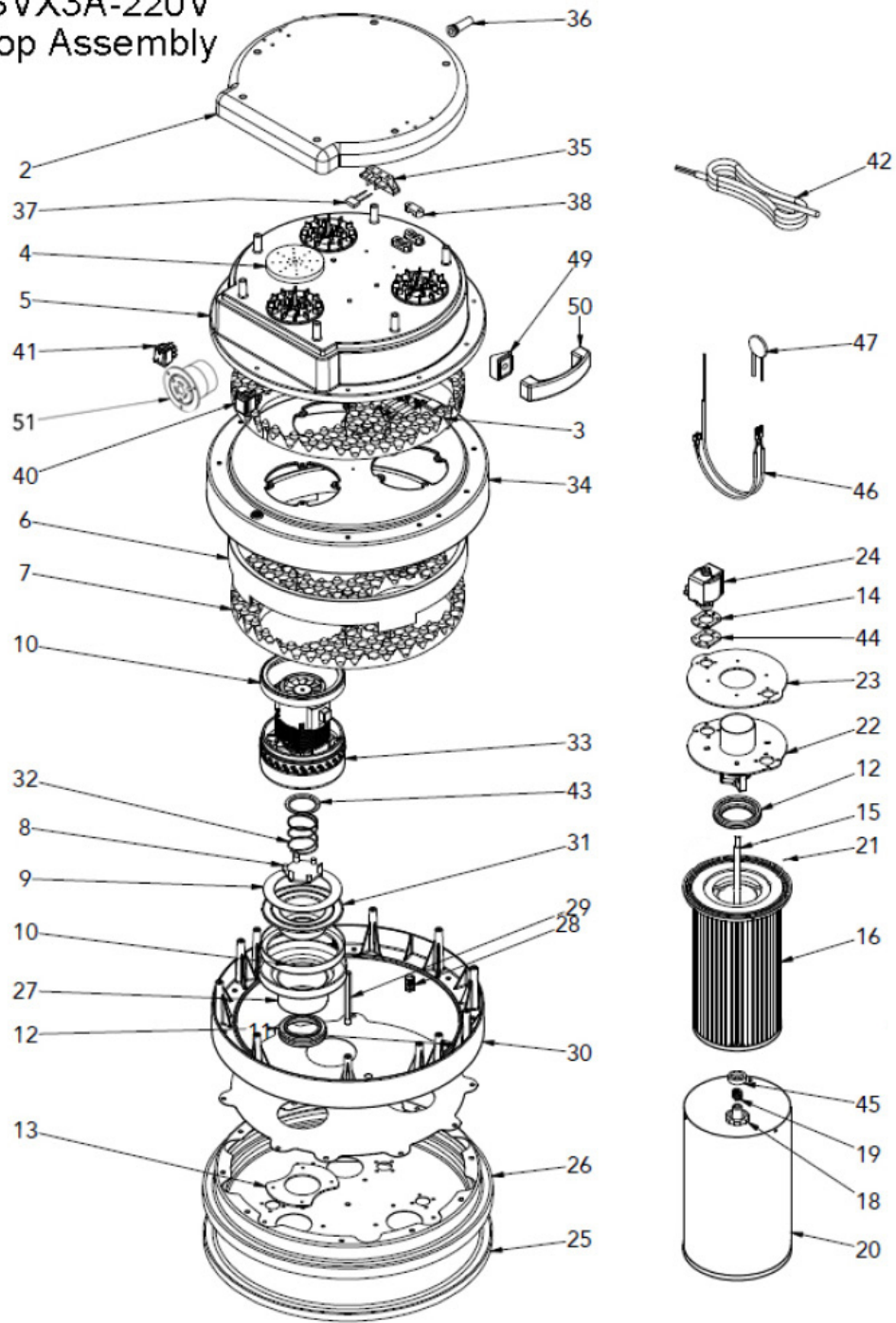

20. TOP ASSEMBLY - 220V

ITEM NO.	PART NUMBER	DESCRIPTION	QTY.
2	SVX-UHC3A	UPPER HEAD COVER (TOP) SVX3A	1
3	SVX-BOARD-230	ELECTRONIC BOARD 230V	1
4	SVX-SPR	SOUND PROOFING RING 60 D:100X10 (FOR AUTOMATIC MODELS ONLY)	3
5	SVX-HC3A-220V	HEAD COVER (MIDDLE) SVX3A 220	1
6	SVX-SPRS	SOUND PROOFING RING STRIP 50X10X1250	1
7	SVX-SPS3A	SOUND PROOFING SPONGE (FOR SVX3A)	1
8	SVX-VM-BY-PASS	VALVE MOTOR BY-PASS	3
9	SVX-SW-135X109X4	VALVE HOLDER SPONGE (FOR SVX3A)	3
10	SVX-GASKET	GASKET L	6
11	SVX-SPH3A	SOUND PROOFING HOLDER 3 MOTORS COVER	1
12	SVX-CABLE-BUSHING	CABLE BUSHING 60	3
13	SVX-SM-FLANGE	SUCTION MANIFOLD FLANGE (AUTOMATIC MODELS ONLY)	3
14	SVX-WASHER-6HA1	WASHER (AUTOMATIC MODELS ONLY)	6
15	SVX-HOLDER-3A-HEPA	FILTER HOLDER SHAFT (SVX3A ONLY)	3
16	SVX-3A-HEPA	HEPA FILTER - (FOR SVX3-A ONLY, 3 PER UNIT)	3
18	SVX-KNOB-STOPPER	PLASTIC KNOB FILTER STOPPER	3
19	SVX-FIL-PRESS-SPRING	FILTER PRESSURE SPRING	3
20	SVX-FIL-PROTECTION	FILTER PROTECTION 150 H 285	3
22	SVX-SUCT-MANI-CLEAN	SUCTION MANIFOLD	3
23	SVX-SUCT-MANI-GASKET	SUCTION MANIFOLD GASKET	3
24	SVX-SHAKER-230V	SHAKER 230V 50HZ	6
25	SVX-GASKET3A-460	SUCTION HEAD GASKET (FOR SVX3A & TVX MODELS)	1
26	SVX-BC3M	BASE COVER SVX3A	1
27	SVX-MHOLDER-AUTO	MOTOR HOLDER (FOR AUTOMATIC MODELS)	3
28	SVX-CABLEGLAND-PG7	CABLE GLAND WITH TIGHTENING NUT (AUTOMATIC ONLY)	3
29	SVX-M8X95	CENTRAL SPACER (FOR SVX3A)	1
30	SVX-FOAMHOLDER-3A	FOAM HOLDER (FOR SVX3A)	1
31	SVX-MVH	MOTOR VALVE HOLDER	3
32	SVX-VAL-SPRING	VALVE SPRING	3
33	SVX-MOTOR-230	MOTOR	3
34	SVX-MR3A	MOTOR RETAINER (BOTTOM) SVX3A	1
35	SVX-RTBS	RED TERMINAL BLOCK SCREW	1
36	SVX-CABLEGLAND-220V	CABLE GLAND	1
37	SVX-FILMCAPACITOR-A	FILM CAPACITOR (FOR AUTOMATIC MODELS ONLY)	1
38	SVX-CABLESTOPPER	CABLE STOPPER (ALL MODELS)	1
40	SVX-SWITCH-PURGE	PUSH BUTTON SWITCH WITH CUFF (FOR SVX3-A & SVX2-A, 1 PER UNIT)	1
41	SVX-SWITCH-ON/OFF	16 AMP SWITCH WITH CUFFS (1 FOR AUTOMATIC UNIT / 2 FOR SVX2-M / 3 FOR SVX3-M)	1
42	SVX-CABLE-3GX10	CABLE	1 (33')
43	SVX-RINGFITTING-A	RING FITTING (FOR AUTOMATIC MODELS ONLY)	3
44	SVX-WASHER-6HA2	WASHER (AUTOMATIC MODELS ONLY)	6
45	SVX-ZPSRS-A	ZINC PLATED SEALING RING STRUT	3
46	SVX-VPW-3A	VIBRATOR POWER WIRE (FOR SVX3A)	3
47	SVX-S14K250	VARISTOR (AUTOMATIC MODELS ONLY)	3
49	SVX-HFB-A	HANDLE FIXING BRACKET (FOR AUTOMATIC MODELS ONLY)	4
50	SVX-HANDLE-RED-A	RED HANDLE (FOR AUTOMATIC MODELS ONLY)	2
51	SVX-PLUG-220	50AMP DISTRIBUTION BOX	1

21. HOPPER ASSEMBLY - 110V & 220V

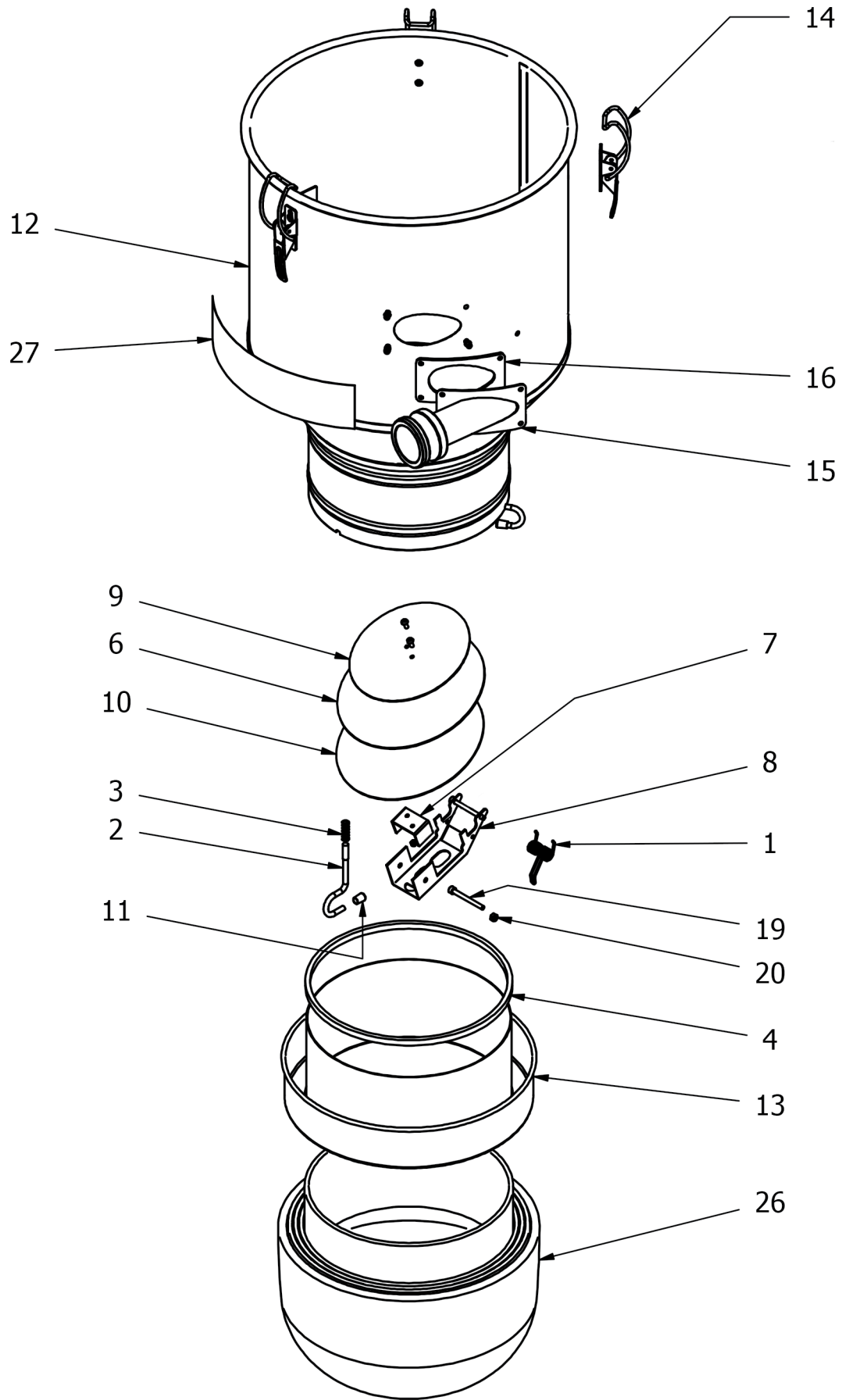

21. HOPPER ASSEMBLY - 110V

ITEM NO.	PART NUMBER	DESCRIPTION	QTY.
1	SVX-DSRFD	DOUBLE SPRING RETURN FLAP DISK	1
2	SVX-CONTAINERLOCK	INFINITY BAG CONTAINER LOCK	3
3	SVX-LOCKSPRING	INFINTIY BAG LOCK SPRING	3
4	SVX-HOPPERGASKET-A	HOPPER GASKET FOR AUTOMATIC MODELS	1
6	SVX-OVAL-GASKET	OVAL SPONGE RUBBER FLAP GASKET	1
7	SVX-CJOINTFLAP	C JOINT FLAP	1
8	SVX-FLAPARM	FLAP ARM	1
9	SVX-UPPERPLATE-FLAP	UPPER PLATE FLAP	1
10	SVX-LOWERPLATE-FLAP	LOWER PLATE FLAP	1
12	SVX-HOPPER-3A	BLUE HOPPER FOR SVX3A(+)	1
13	SVX-IBAGCONTAINER	INFINITY BAG CONTAINER FOR AUTOMATIC MODELS	1
14	SVX-HOOKS-LARGE	LARGE HOPPER HOOK (SVX3A & TVX MODELS ONLY)	3
15	SVX-INLET	INLET FOR AUTOMATIC MODELS (Please refer to page 19 for all camlocks related to the SVX line)	1
16	SVX-INLETGASKET	INLET GASKET FOR AUTOMATIC MODELS	1
26	I-1376013	INFINITY CONTINUOUS BAGS	1
27	SVX-HOPPER-PROTECTOR	RUBBER PROTECTOR FOR HOPPER	1

23. FRAME ASSEMBLY - 110V

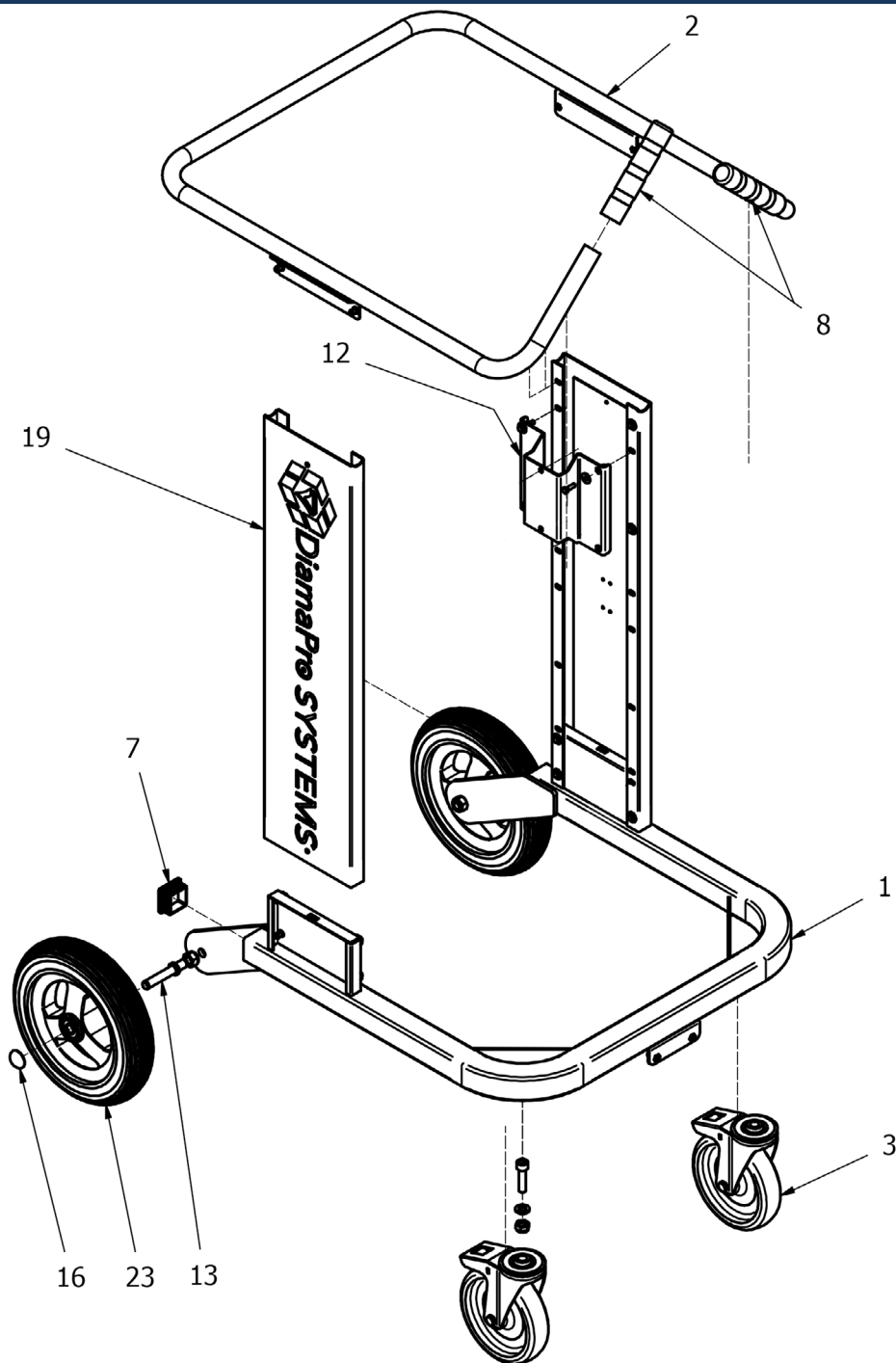

ITEM NO.	PART NUMBER	DESCRIPTION	QTY.
1	SVX-LF3A	LOWER FRAME (SVX3A ONLY)	1
2	SVX-FRAMEHANDLE-3A	FRAME HANDLE (SVX3A ONLY)	1
3	SVX-CASTER-A	FRONT CASTER (AUTOMATIC MODELS ONLY)	2
7	SVX-CAP-40X40	CAP 40X40 (AUTOMATIC MODELS ONLY)	2
8	SVX-FRAMEGRIP-A	RED FRAME HANDLE GRIP	2
12	SVX-SLIDESUPPORT-A	SLIDING CHAMBER SUPPORT (AUTOMATIC MODELS ONLY)	2
13	SVX-PIN	PIN AND NUT FOR SVX-TIRE	2
16	SVX-RRING-A	RETAINING RING (AUTOMATIC MODELS ONLY)	2
19	SVX-SIDEFRAAME-A	SIDE FRAME (AUTOMATIC MODELS ONLY)	2
23	SVX-TIRE	REAR WHEEL (ALL SVX MODELS)	2

24. FRAME ASSEMBLY - 220V

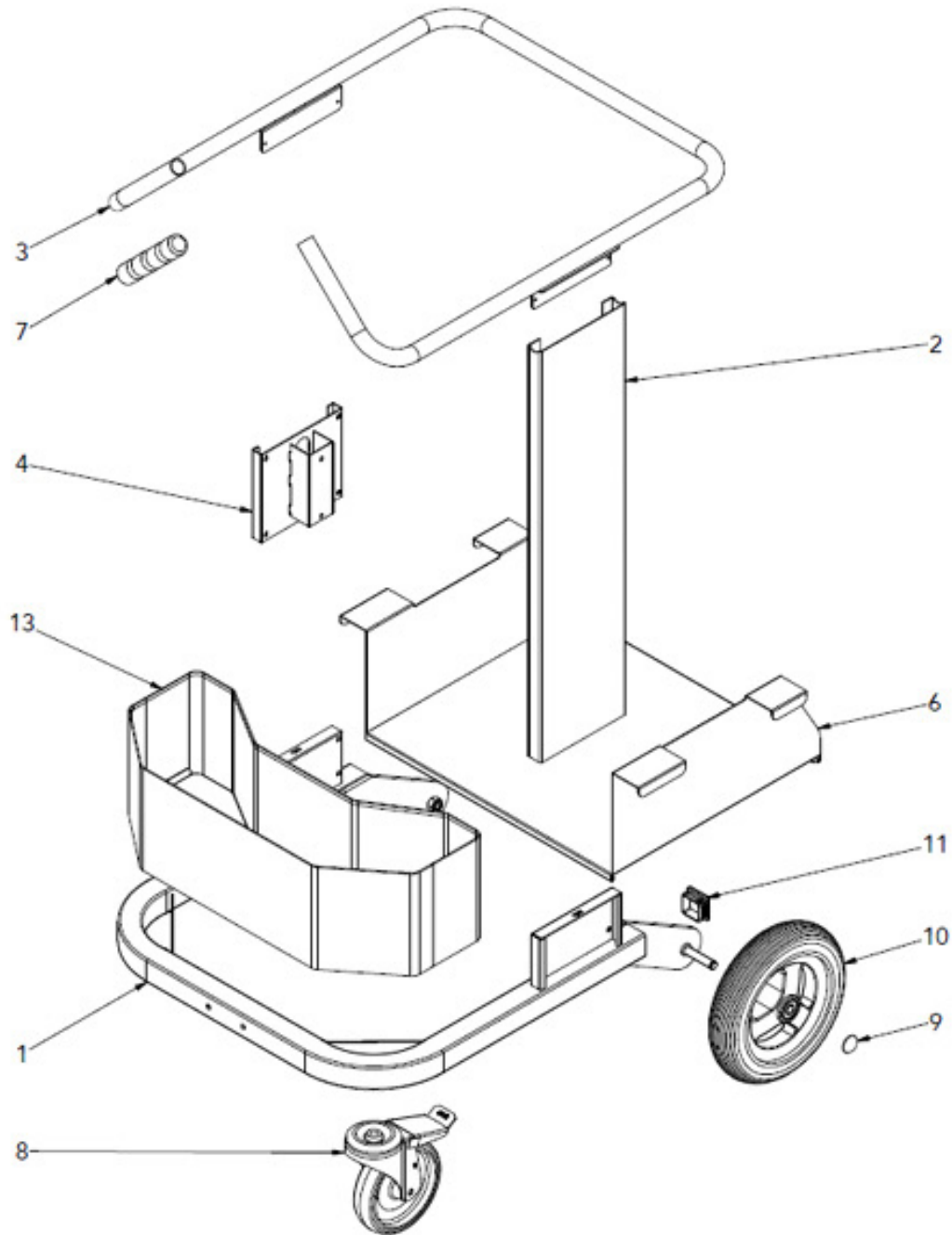

ITEM NO.	PART NUMBER	DESCRIPTION	QTY.
1	SVX-LF3A	LOWER FRAME (FOR SVX3A)	1
2	SVX-SIDEFRA-A	SIDE FRAME (FOR AUTOMATIC MODELS)	2
3	SVX-FRAMEHAND-3A	FRAME HANDLE (FOR SVX3A)	1
4	SVX-SLIDESUPP-A	SLIDING CHAMBER SUPPORT (FOR AUTOMATIC MODELS)	2
6	SVX-BAGHOLDER-3A	INFINITY BAG BASE (FOR SVX3A)	1
7	SVX-FRAMEGRIP-A	RED FRAME HANDLE GRIP (FOR SVX3A)	2
8	SVX-CASTER-A	FRONT CASTER (FOR SVX3A & SVX2A ONLY, 2 PER UNIT)	2
9	SVX-RRING-A	RETAINING RING (FOR AUTOMATIC MODELS ONLY)	2
10	SVX-TIRE	REAR WHEEL (ALL SVX MODELS)	2
11	SVX-CAP-40X40	CAP 40X40 (FOR AUTOMATIC MODELS)	2
13	SVX-TROLLEY-3A	TROLLEY (FOR SVX3A)	1

25. ACCESSORIES - 110V & 220V



25. ACCESSORIES - 110V & 220V

ITEM NO.	PART NUMBER	DESCRIPTION
1	SVX-WAND-2	STEEL WAND FOR FLOOR TOOL
2	SVX-FLOOR TOOL-2	WET/DRY PLASTIC FLOOR TOOL
3	SVX-BLACKHOSE-CUFF	CUFFS FOR 2" BLACK HOSE
4	SVX-HOSE-STANDARD-2-NC	2" STANDARD BLACK HOSE
5	SVX-SQUEEGEE-BLADES	BLADE SET FOR FLOOR TOOL 15-1/2 X 17-1/4
6	DP-TPLUG	T-PLUG ADAPTER 15A
7	DP-HOSECLAMP-3	3" HOSE CLAMP (57-76MM) FOR 2" HOSES
8	DP-C2530	2.5" FEMALE CAMLOCK W/ 3" SMOOTH SHANK
9	DP-C300	3" FEMALE CAMLOCK
10	DP-C3020	ALUMINUM 3" FEMALE CAMLOCK TO 2" HOSE SHANK
11	DP-C2520	2.5" FEMALE CAMLOCK W/ 2" SMOOTH SHANK
12	DP-A250	2.5" MALE CAMLOCK
13	SVX-HOSE-ANTISTATIC-2-NC	2" ANTISTATIC HOSE **DOES NOT INCLUDE CUFFS**
14	SVX-HOSE-ANTISTATIC-2.5-NC	2.5" ANTISTATIC HOSE **DOES NOT COME WITH CUFFS**
15	SVX-HOSE-ANTISTATIC-3-NC	3" ANTISTATIC HOSE **DOES NOT INCLUDE CAMLOCKS**
16	SVX-ANTISTATIC-CUFF	SOFT CUFF FOR 2" ANTISTATIC HOSE
17	201000173	S-LINE 2.5"-2" SOFT CUFF HOSE CONNECTOR

Customer Acknowledgment and Assumption of Responsibility for Modification to any Product.

Customer expressly acknowledges that modification of any equipment, machines, or other products purchased from Niagara Machine, Inc. ("Niagara"), including but not limited to DiamaPro Systems Products (collectively, "Products") through the attempted or actual use or misuse, adjustment, alteration, application of additional components, removal of provided components, repairs or attempted repairs by Customer (collectively, "Modifications") can lead to Product malfunction causing serious risks. Such risks include, but are not limited to, Product damage, bodily injury, death, or loss of or damage to property. Customer agrees that Customer is solely responsible for any Modifications Customer performs on any Product purchased from Niagara, and that Niagara is not responsible and will not be held liable for any claims, damages, or injury arising from Modifications by Customer, including Customer's employees, subcontractors, agents, representatives, affiliates, and assigns, to any Product purchased from Niagara. Customer further acknowledges and agrees that any Modification(s) to a Product may, at DiamaPro Systems' and/or Niagara's election, void any warranty applicable to the Product.

Customer agrees that, to the greatest extent permitted by law, Customer shall indemnify, hold harmless and, at Niagara's request, defend (with counsel reasonably approved by Niagara), Niagara, Niagara's parent, subsidiaries, affiliates and the officers, directors, employees and agents of Niagara (individually and collectively "Niagara Indemnitees") from and against, and pay or reimburse them for any and all third-party claims, losses, damages, liabilities, lawsuits and expenses (including reasonable attorneys' fees) relating to bodily injury, death, or loss of or damage to property caused by or arising from any Modification to a Product by Customer, its employees, subcontractors, agents, representatives, affiliates, and assigns (individually and collectively, "Customer Group"), with respect to the Products Customer purchases from Niagara.

Customer acknowledges that Customer has read and understands these terms, and voluntarily assumes full and sole responsibility for any and all effects arising from any Modification to a Product by Customer Group.



DiamaPro®

SYSTEMS

DiamaPro® Systems
3343 Peachtree Road NE
Suite 145 #24
Atlanta, GA 30326
470-977-2323