



DiamoPro®
SYSTEMS

OWNER'S MANUAL

DP-JSX-10

WALK-BEHIND SAW



OPERATION & MAINTENANCE MANUAL

SAVE THESE INSTRUCTIONS FOR FUTURE REFERENCE

INTRODUCTION

Thank you for purchasing a DIAMAPRO SYSTEMS® product. This manual provides information and procedures to safely operate and maintain the DP-JSX-10. For your own safety and protection from injury, carefully read, understand, and observe the safety instructions described in this manual. Keep this manual or a copy of it with the machine. If you lose this manual or need an additional copy, please contact DiamoPro Systems®. This machine is designed and built with user safety in mind; however, it can present hazards if improperly operated and serviced. Please follow the operating instructions carefully. If there are any questions regarding operating or servicing of this machine, please contact DiamoPro Systems®.

Disclaimer: DiamoPro Systems® and its affiliates take no responsibility for any damage, injury or death resulting from the incorrect or unsafe use of this product. Use of this product should be undertaken by competent persons only. It is the operator's responsibility to ensure that the following safety procedures are followed. If you are unsure, do not operate this product.

1. SAFETY INSTRUCTIONS

1.1 KNOW THE RULES & YOUR EQUIPMENT

Most Job sites have rules governing equipment use & maintenance. Before starting at a new work location, check with the supervisor or safety coordinator. Ask about any rules or regulations you need to abide. OSHA enforces federal laws within the United States that apply to the safe operation, application, & maintenance of equipment on job sites. It is the employer's responsibility to comply with these laws.

Do not operate this machine unless you have read the operations and maintenance manual carefully. Read any additional instructions included from other manufacturers and organizations and the Masonry and Concrete Saw Manufacturers Institute. Learn the applications and limitations as well as the specific potential hazards related to this tool.

1.2 RECEIVE PROPER TRAINING

Do not operate this machine unless you have received operational and maintenance training from a DiamoPro Systems® representative or from an authorized distributor for DiamoPro Systems®.

1.3 PROTECT YOUR FEET

Observe all applicable local, state and federal safety regulations. Wear OSHA approved foot protection.

1.4 PROTECT YOUR EYES

Observe all applicable local, state and federal safety regulations. Wear OSHA approved safety glasses.

1.5 PROTECT YOUR LUNGS

Breathable silica may be generated by use of this product. Silica can cause severe and permanent lung damage, cancer, and other serious diseases. Do not breathe the dust. Do not rely on your sight or smell to determine if the dust is in the air. Silica may be in the air without a visible dust cloud. If air monitoring equipment for silica is not provided by your employer at your work site, you MUST wear appropriate respiratory protection when using or servicing the machine. If dry cutting, be sure to use a HEPA filtered dust collector. Consult your employer and OSHA regarding the appropriate respiratory protection.

1.6 PROTECT YOUR HEARING

Observe all applicable local, state and federal safety regulations. Wear OSHA approved hearing protection.

1.7 DRESS PROPERLY

Do not wear loose clothing or jewelry that can be caught in moving parts. Wear protective hair covering to contain long hair. Keep hair away from

motor air vent. Rubber gloves and non-skid footwear are recommended when working outdoors.

1.8 AVOID A DANGEROUS ENVIRONMENT

Do not expose machine to rain. Do not use machine in wet conditions. Keep work area well lit. When working at an elevated location, pay attention to articles and persons below.

1.9 BEWARE OF HIDDEN DANGERS IN CONCRETE

Rebar or utility lines may be buried in concrete. Disconnect the power to any utility lines. If these items are to be missed, clearly mark the area. If these items are to be cut, check the blade manufacturer's guidelines on material to be cut.

1.10 KEEP WORK AREA CLEAN. DO NOT RUN OVER ANYTHING

Loose objects could be thrown from crack. Make sure area to be cut is clear from people and any loose objects, nuts, bolts, etc. Never run over any loose objects

1.11 KEEP CHILDREN AND VISITORS AWAY

Do not allow anyone to stand in line with the blade path. Do not let children or visitors contact machine or extension cord. Keep children and visitors away from the work area.

1.12 AVOID FLAMMABLE LIQUIDS OR GASES

Engines and diamond blades produce heat and sparks during operation. Never use machines in dangerous sites containing flammable, combustible or explosive materials such as lacquer, paint, benzene, thinner, gasoline, gases, and adhesive agents.

1.13 AVOID CONTACT WITH HOT BLADE AND BLADE GUARD

The blade and blade guard become hot during operation and remain hot after stopping the engine. Do not touch the blade and blade guard without proper hand protection.

1.14 KEEP FIRM GRIP ON MACHINE

During normal operation as instructed in Section 6.0, keep a firm hold on the handle grips and maintain control of the machine until the blade completely stops.

1.15 CHECK BLADE AND MACHINE ROTATION DIRECTION

Never operate a blade in the wrong rotation direction. Check the machine rotation direction and blade direction when mounting a blade.

1.16 CHECK BLADE MAXIMUM ALLOWABLE SPEED

Check the maximum operating speed of the machine and blade. Never use a blade rated less than the machine's maximum speed rating.

1.17 CHECK BLADE FOR CRACKS, DAMAGE, AND MISALIGNMENT

Never use a cracked, damaged, or misaligned blade. After mounting blade, rotate by hand to check for proper alignment.

1.18 CHECK DIAMOND BLADE FOR WARNINGS

Many diamond blades contain a chemical known to the state of California to cause cancer and/or birth defects or other reproductive harm. Diamond blades improperly used are dangerous. Comply with American National Standards Institute Safety Code B71 and Occupational Safety & Health Act covering SPEED, SAFETY GUARDS, FLANGES, MOUNTING PROCEDURES, GENERAL OPERATING RULES, HANDLING, STORAGE & INSPECTION AND GENERAL MACHINE CONDITIONS. Read Diamond Blades Safety Manual before use.

1.19 DO NOT FORCE WRONG SIZE OR TYPE BLADE ONTO MACHINE

Do not force a blade onto the machine shaft or alter the size of the arbor mounting hole. Be certain that the drive pin is in place through the blade when tightening the blade nut. Never add a drive pin hole or modify a blade.

1.20 USE CORRECT SAW AND ACCESSORIES

Do not force a small saw to do the job of a heavy-duty saw. Do not use the saw for improper applications. Never cut material for which the blade was not designed. Check blade manufacturer's guidelines on material to be cut.

1.21 STORE IDLE EQUIPMENT

The machine, blades and tools should be stored in a dry and secure location when not in use. Keep equipment out of reach of children.

1.22 DO NOT FORCE SAW

The saw will do the job better and safer at the rate for which it was designed.

1.23 OBTAIN MATERIAL SAFETY DATA SHEET (MSDS) FOR ALL WORK SURFACE MATERIALS

This includes primers, all coatings, adhesives, tile and crack filling materials, etc. Do not attempt to cut, clean out or remove material without MSDS information. Consult MSDS sheet for hazards information. Be aware that some materials are explosive as a dust.

1.24 DO NOT OVERREACH

Keep proper footing and balance at all times.

1.25 MAINTAIN MACHINE WITH CARE

Keep machine clean and follow maintenance procedures for better and safer performance. Keep handles dry, clean, and free from oil and grease. Follow instructions for lubricating and changing accessories.

1.26 REMOVE ADJUSTING TOOLS

Form a habit of checking to see that tools such as adjusting wrenches are removed from the machine and properly stored before starting the engine.

1.27 STAY ALERT

Watch what you are doing. Use common sense. Do not operate machine when you are tired or fatigued.

1.28 DO NOT USE DRUGS, ALCOHOL, MEDICATION

Do not operate machine while under the influence of drugs, alcohol, or any medication.

1.29 KEEP THE RIGHT PARTS IN THE RIGHT POSITIONS

Do not operate machine with parts missing or improperly mounted.

1.30 CHECK DAMAGED PARTS

Verify all machine guards are in good condition and will function properly before using the machine. Check for alignment of moving parts, binding of moving parts, breakage of parts, mounting, and any other conditions that may affect machine operation. A guard, power switch or other part that is damaged should be properly repaired or replaced by an authorized service center unless indicated elsewhere in this instruction manual. Do not operate machine if lever or engine on/off switch does not function properly.

1.31 SECURELY MOUNT ACCESSORIES AND BLADES TO THE MACHINE

Extra care must be taken when using saws on an elevated location to prevent injury to someone on a lower level in the event the tool or accessory should drop. Do not operate without fall protection for operator and debris protection for public.

1.32 NEVER TOUCH THE MOVING PARTS

Never touch moving parts such as blades, belts and others.

1.33 STOP OPERATION IMMEDIATELY IF ANY ABNORMALITY IS DETECTED

Stop using machine immediately if any abnormalities are observed during operation. Examples of abnormalities include unusual noise and vibration.

1.34 WHEN REPLACING A PART, USE THE SAME TYPE AND QUALITY

When replacing a component part with a new one, use only the same type and quality of new part. Never attempt to repair a machine if you are unfamiliar with proper procedures and techniques required.

1.35 NEVER DISABLE THE LEVER

Do not modify, disable, or attempt to permanently engage the lever. Do not operate a machine if lever is not functioning. This could lead to serious injury or death.

1.36 LOAD AND UNLOAD SAFELY

Use proper heavy lifting procedures. Read & understand manuals before loading & unloading.

1.37 STORAGE

Always store equipment properly when it is not being used. Equipment should be stored in a clean, dry location and out of reach of children.

1.38 SAVE THESE INSTRUCTIONS

Refer to this operations and maintenance manual as well as any additional instructions included from other manufacturers and organizations and the Masonry and Concrete Saw Manufacturers Institute®. Never permit anyone to operate the machine without proper instructions.

DUST WARNING

Cutting, especially when DRY cutting, generates dust that comes from the material being cut, which frequently contains silica.

When dry cutting, be sure to use a HEPA filtered dust collector.

Silica is a basic component of sand, quartz, brick clay, granite and numerous other minerals and rocks. Exposure to excessive amount of such dust can cause:

- Respiratory diseases (affecting your ability to breathe), including chronic bronchitis, silicosis and pulmonary fibrosis from exposure to silica. These diseases may be fatal;
- Skin irritation and rash; and
- Cancer according to NTP* and IARC*
*National Toxicology Program, International Agency for Research on Cancer

Take precautionary steps

- Avoid inhalation of and skin contact with dust, mist and fumes;
- Wet cut when feasible, to minimize dust;
- Wear and ensure that all bystanders wear appropriate respiratory protection such as dust masks designed to filter out microscopic particles. (See OSHA 29 CFR Part 1910.1200)

California Prop 65 Warning: Use of this product can cause exposure to materials known to the State of California to cause cancer and/or birth defects or other reproductive harm.

DANGER

ELECTRICAL SHOCK HAZARD

Warnings!

These instructions are only intended to show you the set-up of our saw. Do not use until you have been trained on how to properly operate a walk behind concrete saw.

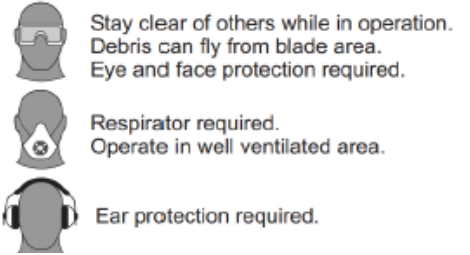

PRODUCT SET-UP

Set-Up: Red Arrows (Fig. 1)

1. Install the control and lift handle as shown in Fig. 1.
2. Hang cord on handle cord rest. Secure on rest using the factory provided twist tie.
3. Apply powerhead trigger lock. Plug cord into the electrical box.

Never leave the unit plugged in while unattended or while replacing the blade

Figure 1

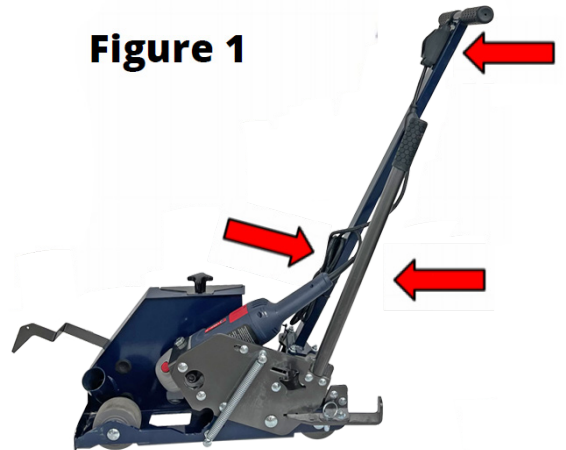

Blade Installation: Green Arrows (Fig. 2)

1. Unplug the power cord from the electrical box. Remove the blade guard.
2. Remove outer blade clamp and install the blade.
3. Firmly tighten the blade.

We recommend using a DiamaPro Systems® 8" Diamond Blade

Blade Pointer Alignment: Blue Arrows (Fig. 2)

1. After proper blade installation, align the rear pointer and the blade with a known straight edge.
2. Using the supplied washer/shims, align the front pointer to the known straight edge. Be sure to tighten the front pointer bolt.

Figure 2

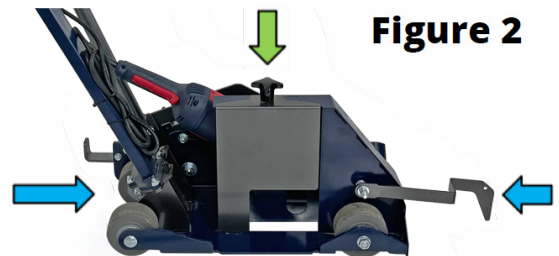

Feature Call Outs: Yellow Arrows (Fig. 3)

- 2-inch dust port: Minimum 250 CFM required
- Blade depth adjustment knob. Loosen knob and slide left or right to set blade depth.
- Foot lever locks the motor in the UP position. Be sure to install the lock-out pin while not in use and for transportation.

Figure 3

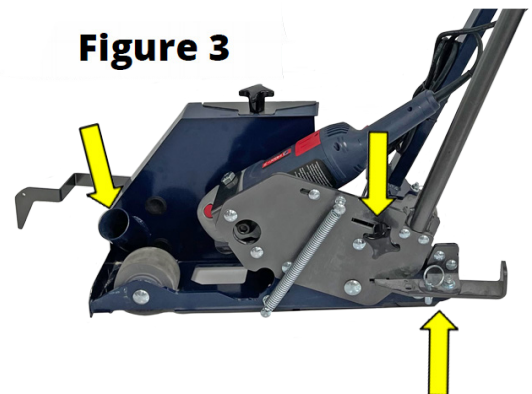

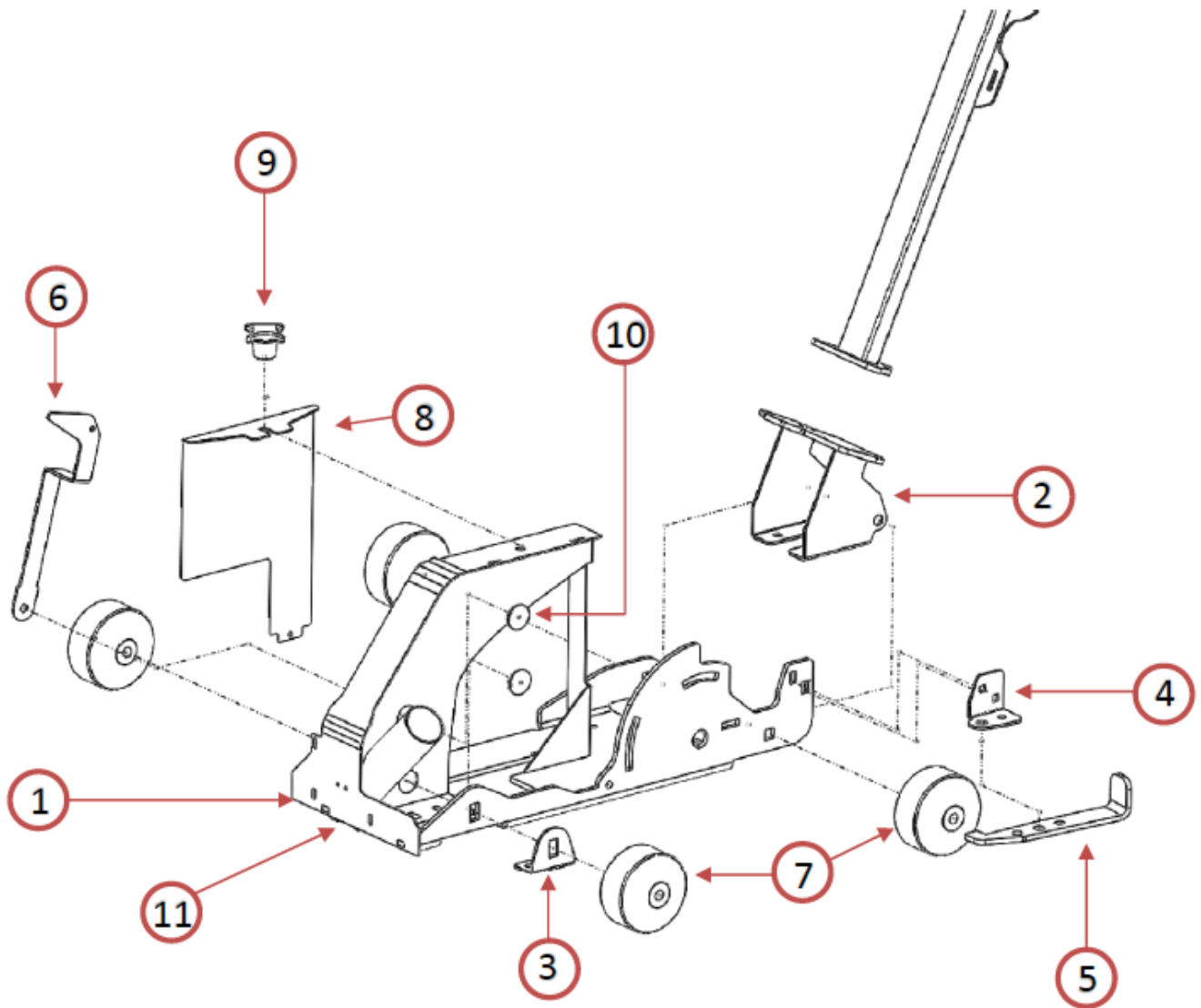

Part Number	Description
10 - 1	SAW BASE
10 - 2	HANDLE/REAR WHEEL MOUNT
10 - 3	ADJUSTABLE FRONT WHEEL MOUNT
10 - 4	MOTOR LOCK MOUNT
10 - 5	MOTOR LOCK
10 - 6	BLADE POINTER
10 - 7	WHEELS (SOLD INDIVIDUALLY)
10 - 8	BLADE GUARD
10 - 9	4-ARM KNOB
10 - 10	HOLE PLUG
10 - 11	DUST DEFLECTOR

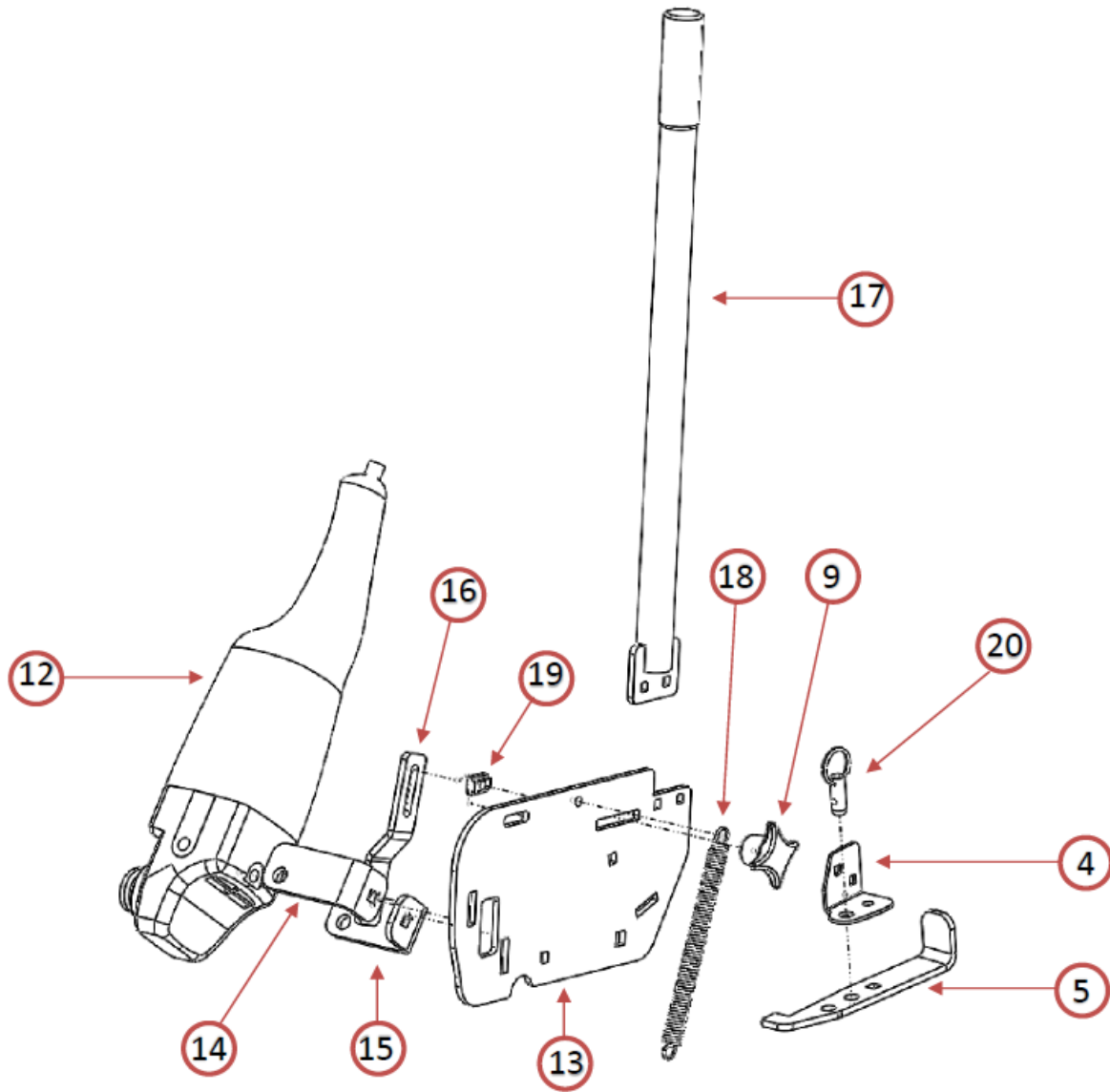

Part Number	Description
10 - 12	DP-HGX-7
10 - 13	MOTOR MOUNTING PLATE
10 - 14	UPPER MOTOR MOUNT
10 - 15	LOWER MOTOR MOUNT
10 - 16	CENTER MOTOR MOUNT
10 - 17	LIFT/LOWER HANDLE
10 - 18	TENSION SPRING
10 - 19	DEPTH STOP
10 - 20	DETENT PIN

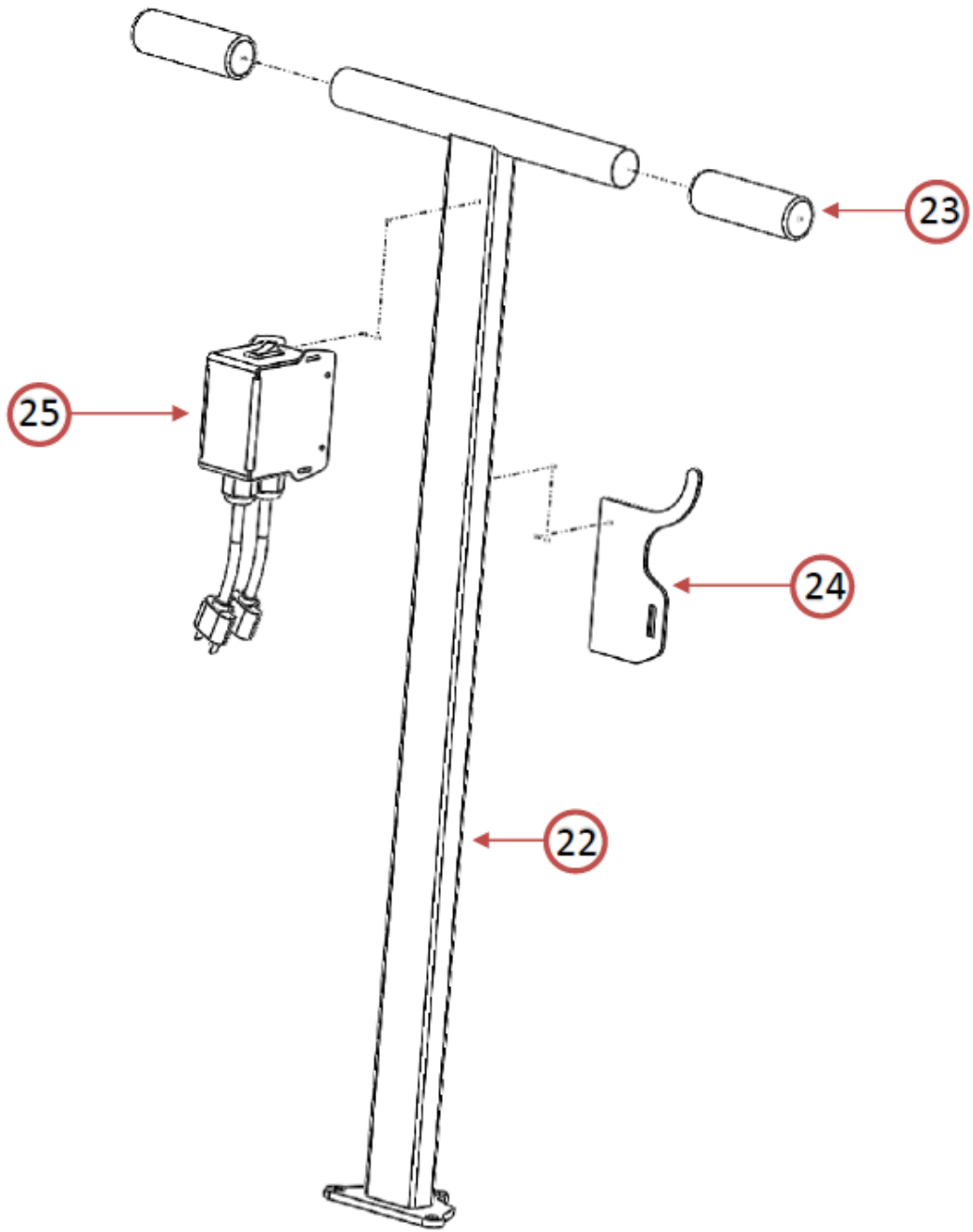

Part Number	Description
10 - 21	COMPLETE ASSEMBLY
10 - 22	HANDLE
10 - 23	HANDLE GRIP
10 - 24	CORD WRAP
10 - 25	ELECTRICAL BOX

Customer Acknowledgment and Assumption of Responsibility for Modification to any Product.

Customer expressly acknowledges that modification of any equipment, machines, or other products purchased from Niagara Machine, Inc. ("Niagara"), including but not limited to DiamaPro Systems Products (collectively, "Products") through the attempted or actual use or misuse, adjustment, alteration, application of additional components, removal of provided components, repairs or attempted repairs by Customer (collectively, "Modifications") can lead to Product malfunction causing serious risks. Such risks include, but are not limited to, Product damage, bodily injury, death, or loss of or damage to property. Customer agrees that Customer is solely responsible for any Modifications Customer performs on any Product purchased from Niagara, and that Niagara is not responsible and will not be held liable for any claims, damages, or injury arising from Modifications by Customer, including Customer's employees, subcontractors, agents, representatives, affiliates, and assigns, to any Product purchased from Niagara. Customer further acknowledges and agrees that any Modification(s) to a Product may, at DiamaPro Systems' and/or Niagara's election, void any warranty applicable to the Product.

Customer agrees that, to the greatest extent permitted by law, Customer shall indemnify, hold harmless and, at Niagara's request, defend (with counsel reasonably approved by Niagara), Niagara, Niagara's parent, subsidiaries, affiliates and the officers, directors, employees and agents of Niagara (individually and collectively "Niagara Indemnitees") from and against, and pay or reimburse them for any and all third-party claims, losses, damages, liabilities, lawsuits and expenses (including reasonable attorneys' fees) relating to bodily injury, death, or loss of or damage to property caused by or arising from any Modification to a Product by Customer, its employees, subcontractors, agents, representatives, affiliates, and assigns (individually and collectively, "Customer Group"), with respect to the Products Customer purchases from Niagara.

Customer acknowledges that Customer has read and understands these terms, and voluntarily assumes full and sole responsibility for any and all effects arising from any Modification to a Product by Customer Group.



DiamaPro®

S Y S T E M S

DiamaPro® Systems
3343 Peachtree Road NE
Suite 145 #24
Atlanta, GA 30326
470-977-2323