



Diamapro[®]
SYSTEMS

OWNER'S MANUAL
DP-SCRUB20
AUTO SCRUBBER



USER & MAINTENANCE BOOK

SAVE THESE INSTRUCTIONS FOR FUTURE REFERENCE



WARRANTY REGISTRATION CARD

Form must be completed and submitted within 30 days from the date of purchase.

Customer Information

First and Last Name

Company Name

Address

City

State

Zip Code

Phone Number

Email

Machine Information

Machine Type

Machine Model

Serial #

Purchase Date (dd/mm/yy)

Diamapro® Systems
3343 Peachtree Road NE
Suite 145 #24
Atlanta, GA 30326

Thank you for purchasing our products. This operation manual will provide you with a comprehensive guide to operate this machine. Please read this manual carefully before you use the machine and retain it for future reference.

OPERATIONAL SAFETY INSTRUCTIONS

Please read this manual carefully before using this appliance.

In this manual, there are common safety instructions in detail on appliance preparing, operating and maintenance. The operator must obey these accident-preventive regulations when using this machine. The manufacturer does not bear any liability for any accident caused by disobeying these regulations.

This manual is one of the most important pieces of this appliance. Ensure the operator reads or listens to the manufacturer's introduction on this manual. Save this manual where you can easily fetch and read regularly. This manual adopts the following three kinds of figure as the important indication:



INDICATION:

Key information on economical using.

The possible accident caused by disobeying the manual.



NOTICE:

The possible accident and estate damage caused by disobeying the manual



FORBIDDEN

The possible severe damage to person and estate caused by disobeyed instruction.

SAFETY NOTICE



In case any operation is conducted before reading through the manual, the casualty to the operator or others, and even the damage to the machine might be unavoidable. No operation will be permitted without prior training and demonstration



To reduce the risk of fire, this machine is only appropriate for cleaning explosion-proof commercial floorings.



Half-installed or half-fit machine might cause damage to the operator or others, and might also cause casualty to the machine or parts of the machine. Before fitting it in completely, do not conduct any operation on the machine. Before operation, one should make sure all components of the machine are well-preserved.



The maintenance of this machine should be performed by trained and qualified technicians. Before maintenance, unplug the machine from the power outlet for the sake of avoiding more harmful interferences.



Check the batteries, and make sure that the + and – on the batteries are aligned according to the polarity diagram. After it is confirmed that no mistake is made, the battery outlet can be connected to the machine.



This machine is to be charged by DC power supply and thus the + and – on the batteries must never be misaligned. Otherwise, all electric apparatuses of the machine will be damaged.





All storage batteries of various types or brands should have their own appropriate charging units. Mismatching different types of battery chargers may cause battery damage or explosion.





The maintenance service to this machine should be performed by trained and qualified technicians. Otherwise, the machine could be damaged. Since each machine has been tested prior to delivery to guarantee operation on system test, the professional technicians should make sure that all replacement parts or the repaired parts are on fixed connection after inspecting the defects or damages, and parts claimed for adjustment should be fixed again after the maintenance service.

 The electric components of the machine could short circuit when in contact with water or in moist environments. In order to ensure the desiccation of the components, the machine should be wiped and kept in a dry environment after being used.

 Ensure proper ventilation, especially in the area where the batteries are charged. The charger should be equipped with an earth lead connecting through the power supply of three cord wire. For the sake of avoiding electrical shock hazards, it is highly recommended that a leakage circuit-breaker be pre-installed.

 Do not recharge the batteries unless the electric platform truck has been pulled out and the cell cover has been removed (with the exception of the maintenance free battery), since gas bubbles might appear during the process of recharging. Each time after recharging, remember to refit the cell cover to avoid the spilling of acid liquid.

 Do not put any article on the batteries!

 Do not put any article on the handlebar!

 While cleaning the machine, do not run water into the air inlet of the lift pump!

 Safe and economical operation of the machine is only possible if the machine operators are thoroughly familiar with the signs and contents on this Operator's Manual. Failure to do so could be harmful.

 This machine is inappropriate for cleaning rough floors and slopes; Operators cannot sit on the machine while operating it in these circumstances.

 Be aware not to have your hands, legs, or loose clothing in contact with the rotating part of the machine.

 Put warning signs on the surrounding area during operation to inform the operator and others that the floor could be wet with water or detergents.

 Follow safety rules at all times during the process of transportation of this large machine.

CAUTION



Avoid starting the machine or charger where combustible gas or liquid is available.



Avoid laying or placing the machine where combustible gas or liquid is available.

FUNCTIONS AND NOTES

FUNCTION

DP-SCRUB20 is suitable for ceramic tile flooring, marble flooring, epoxy flooring, PVC flooring, diamond flooring, terrazzo flooring, concrete flooring and hard floor cleaning. It has an 18-inch brush or pad driver to clean the floor, and the dirty water will be sucked into a recovery tank by the squeegee. Cleaning is finished after passing over the floor one time. The best feature of this machine quick dirt removal from the floor and it only requires one person.

ATTENTION

1. This machine is a high-efficiency, hard floor scrubber with clean and suction function, but no sweep function. In order to avoid any tangling and blockage, sweep the floor before operation.
2. This machine is suitable for smooth, hard floor cleaning. If you attempt to clean tile floor with gaps or a rough marble floor, although this scrubber can remove dirt, it can not absorb the dirty water completely as it would on a smooth floor.
3. This machine is designed for smooth, hard floors. In order to avoid any potential risk, do not walk and operate on an inclined plane.
4. Store and park the machine on the horizontal surface. Inexperienced people are forbidden to operate the machine.
5. Do not start or store the machine in an area with flammables, explosives, and chemical medicine.
6. Operator is forbidden to wear slippers or be barefoot.
7. Do not put hands or feet under the moving brush pad.
8. Keep the electrical control parts away from water and any other liquid, it is useful to wipe the machine with a wet cleaning cloth.
9. Maintenance and amendment should be done by professional personnel.

FUNCTIONS AND NOTES

Battery-powered and equipped with an automatic walking device, The DP-SCRUB20 is a professional floor-cleaning machine with following characteristics:

1. Simple operation

All actions including accelerating, stopping or retreating can be conducted by operating on the same handlebar. When this machine retreats to its limiting position, its emergency stop switch will drive the machine in the opposite direction after being pressed by the operator, so as to prevent the operator from being injured.

2. Power indication

Power can be indicated by different colored LCD, so that the operator is informed of the work load.

3. Convenient maintenance

The recovery tank is detachable, you can take it off from the machine, which is convenient for cleaning. You can rinse the filter by screwing the floating frame. Or you can drain out the water in the solution tank separately, which is convenient for machine maintenance.

4. The dirty water tank cover is transparent, for easily checking tank levels. The transparent water level pipe clearly shows the water level. The suction motor is fixed under the dirty water tank for silent cleaning.

5. Pressurized function makes cleaning much easier, even for a floor with heavy dirt.

6. Convenient for maintenance

Squeegee replacement is quick and convenient.

Loosen the two fixed squeegee knobs in the suction squeegee, pull off the suction hose connection, then take off the suction part. Replace the back squeegee by loosening the fastener. Reverse the upper and lower to reuse the squeegee.

SPECIFICATIONS

MODEL	DP-SCRUB20
WORKING WIDTH OF BRUSH DISK (IN.)	20
WORKING WIDTH OF SQUEEGEE (IN.)	30
SOLUTION TANK CAPACITY (GAL)	13
RECOVERY TANK CAPACITY (GAL)	15
BRUSH SPEED (RPM)	200
BRUSH PRESSURE (LBS)	77
VOLTAGE (V)	24
SUCTION MOTOR	24V 550W
BRUSH MOTOR	24V 750W
MAGNETIC VALVE POWER	24V 12W
BATTERY CAPACITY (AH)	2X12V / 100
WEIGHT (LBS)	238
TRANSPORTATION PACKAGE SIZE (IN.)	51X25X40

BEFORE FIRST USE

New machines should be operated according to the following procedures during its first use.

(The operation should be implemented under the instruction of the sales engineer assigned by the company or agent)

- In order to avoid harmful interference, the machine should be removed from the package carefully and the accompanying documents and spare parts should be checked with great care.
- Only after having a full understanding towards the content of operator's manual, the operator can handle this machine. (A specific person should be assigned to operate this machine)
- The sales engineer or distributor will introduce how to control the handle bar.
- Align the battery and make sure that the batteries and output device are correctly connected. Never make a mistake on the polarity of the battery. The batteries can be connected with the power only after the connection of batteries is confirmed to be right. (This operation can be carried out only after the on-spot inspection has been made by the sales engineer.)
- Connect the squeegee to its frame, then screw down fixed handle and connect the tube to the machine connection.
- Take out the brush disk or needle bed and then choose a proper brush disk or cleaning pad to prepare for installation in accordance with the floor condition.
- With the lock open, the function test is carried on to observe whether the power display and function keys are normal. Only after further tests show nothing wrong, the next operation can be implemented.
- Pour water into the solution tank and then add proper amount of cleaners; install the brush disk.
- Loosen brake pedal.
- Turn on power switch.
- Lay down the squeegee and brush disk.
- Start the suction motor and brush motor.
- Pull the water valve switch upwards to regulate the water output.
- The clean-out operation can be carried out by pushing forward the control handle as well as adjusting the walking rate.
- After cleaning, the brush motor and water absorption motor should be turned off one after another.
- Uplift the brush disk, squeegee and drain the dirty water out. The machine should be cleaned and maintained according to requirements on the operator's manual if a whole day's work is finished.
- Move the machine to the parking place, turn off the power and push down on the brake pedal.

OPERATION AND MAINTENANCE

1. Before operating, big pieces and dust on the ground should be removed. Operation should never be carried out until no dirt, block, and wastepaper could be found on the ground, and all those procedures will help to increase the work efficiency and protect the machine.
2. Insert the activation key into the start switch and rotate it to "1" (Seen in figure1) to check the battery capacity. Operation should never be carried out until the green light turns on (seen in figure2) to indicate the full capacity of the battery.

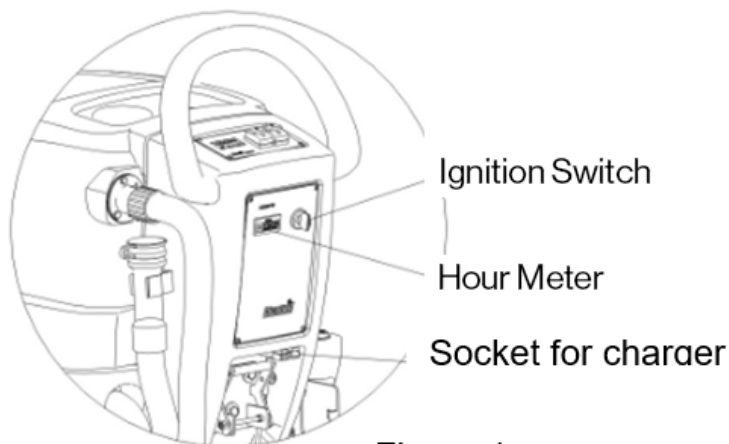

Figure 1

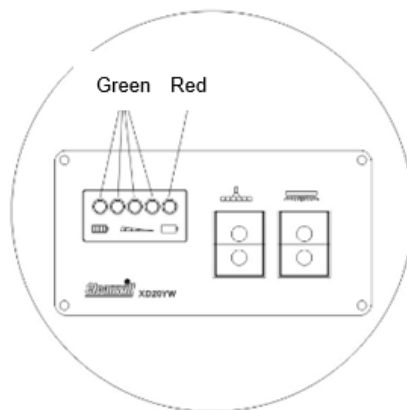

Figure 2

Green light x4	Battery power 100%
Green light x3	Battery power 80%
Green light x2	Battery power 60%
Green light x1	Battery power 40%
Red light flash	Battery needs to be charged

3. Fill the solution tank with clean water, add detergent according to the floor status. There are 2 ways for water filling (see figure 3)

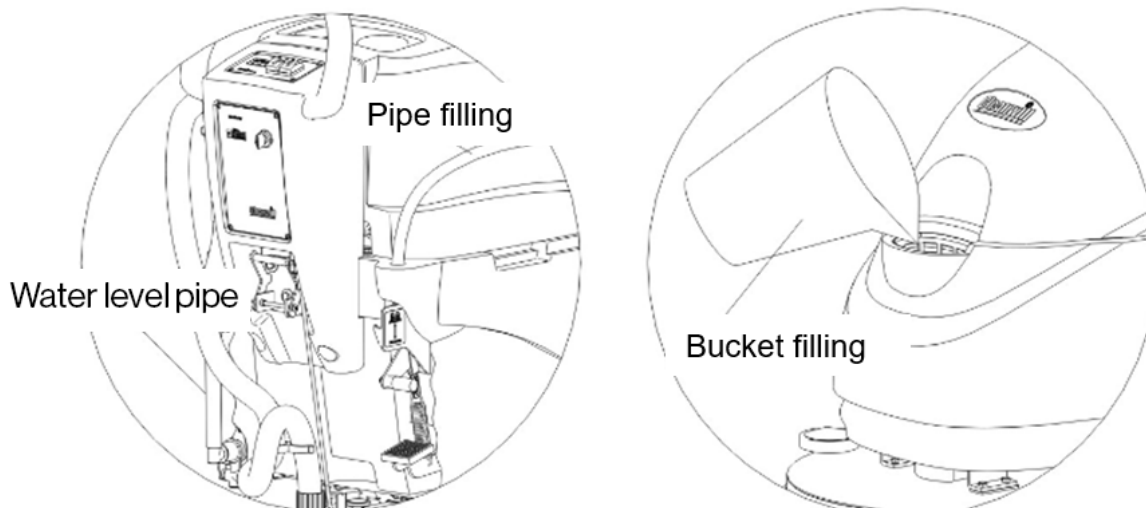

Figure 3

OPERATION AND MAINTENANCE (CONT.)

- Lift the brush pedal to lower the brush disk down to the ground. (Seen in figure4)
Lift the squeegee handle to lower the squeegee down to the ground. (Seen in figure5)

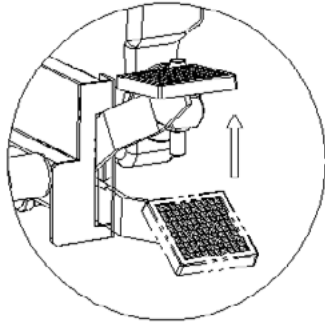

Figure4



Figure5

- Operate the switches to control the brush and suction motor.
 - suction motor on only - use for water sucking.
 - brush on only - clean a floor with heavy dirt
 - both switches on - dual cleaning.
- Use pressurized function when cleaning heavy dirt. Lifting the handle gives the brush more pressure on the floor. Regress to get back to normal. (See figure 6)
- Control the clean water flow rate by operating the water valve knob according to different floor situations. This makes for high-efficiency cleaning and no waste by properly consuming detergent. (see figure 7)

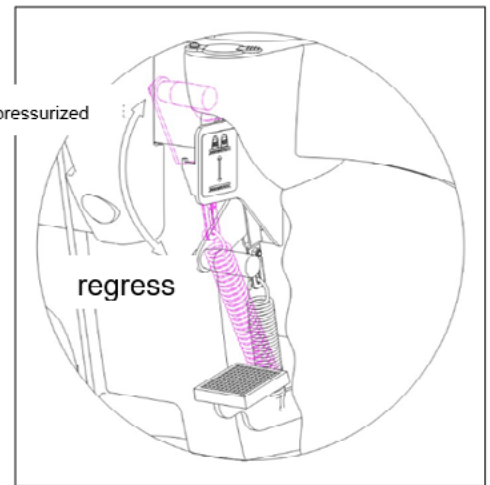
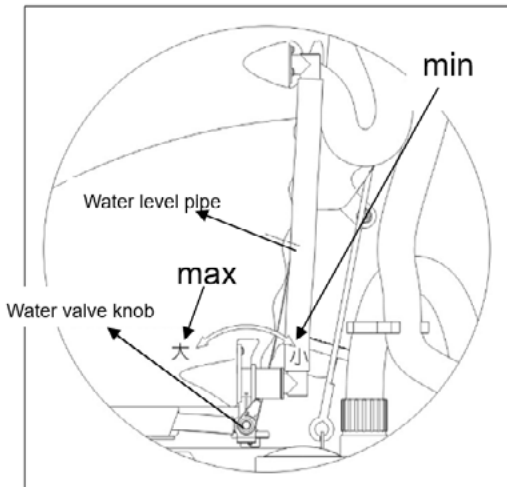

Figure6



Water valve knob

Figure7

OPERATION AND MAINTENANCE (CONT.)

8. With the regulating handle of squeegee, increase or decrease the angle between the squeegee and the floor. The suction of dirt would be efficient with a suitable included angle.(see figure8)
9. Regulating the pressure between the squeegee and the floor
 - screw the small casters up to keep them from touching the floor when the squeegee is working, then adjust the included angle between the squeegee and floor to have the best working status for the squeegee.(the included angle is 90° between the rubber blade and floor).
 - screwing the casters down keeps them on the floor when the squeegee working. Keep adjusting the casters until the squeegee is working efficiency.
 - screw the casters up a bit, to give the squeegee the best working efficiency (see figure 8).

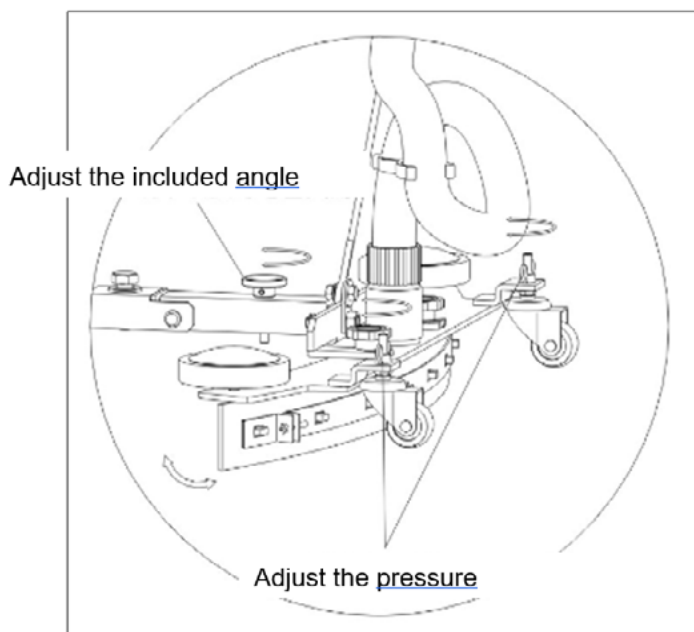

Figure8

10. If there is still cumulation after one way cleaning on a rough floor, just lift up the squeegee and switch on the suction motor, repeat the sucking in that area.

▲ Deep grooves may cause incomplete cleaning, please dispose separately.

- 11.Problems occurred while adjusting the water suction. During the operation, you should stop the machine and check it immediately if the suction motor sounds abnormal, or if the squeegee can not suck or absorb water at all.

- A. When the water level rises to the highest point (the bobber can touch the cap), the sewage should be discharged.

Method: Take the waste pipe out of the clip, open the cap of the tube, discharge sewage to the sewer and clean the recovery tank.
(Seen in figure 9)

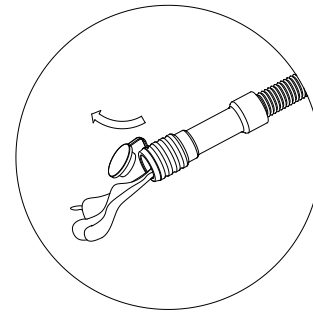
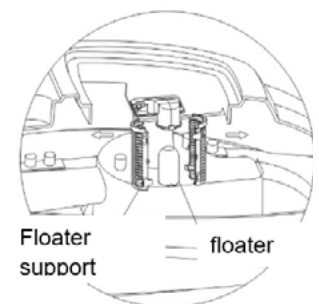

Figure 9

- B. If the water level of the recovery tank is not too high and it's not bubbling, the connection between squeegee and hose should be checked for clogs. In this case, the water sucker will recover normal after being cleaned.
- C. If the water level of recovery tank is not so high but it is bubbling too much, that indicates that excessive cleansers have been added or the cleanser you used is a bubble-productive one. The water absorption motor recovers only after enough bubble-dispelling agents are put into the recovery tank.
- D. Remove the upper cover (see in figure 10), start up the suction motor, and make sure that the suction intake is normal. If the suction is too weak, check the seal and whether the floater is jammed (Seen in figure 10).



OPERATION AND MAINTENANCE (CONT.)

12. Method for replacing the brush disk

A. Installation of the brush pad: Put the brush pad under its cover (If the dial is used, the brush pad should be installed on the dial, then put the brush pad under its cover.) Lay down the brush pedal and align the brush head with the brush clip. Then press, the brush disk will be installed automatically with the running of the motor. And then you can carry out your operation as usual.

B. Removal of the brush pad: There are two ways to remove the brush pad:

The first way is to step on the brush pedal after the work (Uplift the brush pad), then turn off the brush switch. At this time, the brush pad will be removed automatically after the motor stops running. The second way is to press, and then the brush pad should be removed automatically in the condition that the brush pedal is stepped on.



Note: If the brush pad is in the process of being raised, the brush motor should not be started up arbitrarily; otherwise, the brush disk will be removed automatically.

13. Method for replacing the batteries

- turn off all the switches, lift off the dirty water tank (see figure11)
- loosen the strap of the batteries, discharge the connecting cables, replace the batteries separately.

14. Maintenance of the squeegee

As a major component of the machine, the squeegee will be worn away due to friction between the glue bars and the ground during operation. In case it is not effective, the following procedures should be conducted:

- Check whether there is anything in the rubber scraper; (Prepare a towel to wipe the dirty rubber blade at any time)
- Check whether the joint of the squeegee and hose is clogged up by the small pieces. (Remove the connection of hose or squeegee to clean the clog.)
- Check whether the angle between the scraper and ground is proper; if not, you can adjust the angle by regulating the hand wheel. (Seen in figure8)
- Check the wearing condition of the scraper edge. If the wearing condition is so serious that the adjustment will not work, turn over the rubber blade and use another side of it. (see figure 12) If another side is also worn out, it has to be replaced by new rubber blade.

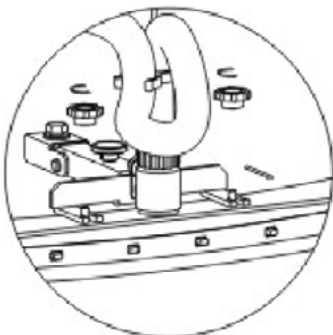

Figure 12

15. Daily upkeep when operation is finished:

- clean the machine surface with a wet and dry cloth, and open the water tank cover to check and make sure there is no damage with the inside seal.
- pumping out the dirty water from the pollution tank, then add more clean water to wash the inside again.
- uplift the brush and the squeegee, pack the machine in a dry, flat place without combustible gas, combustible liquid, chemicals, or fire.
- if unused for a period of time, please disassemble the battery from the machine and clean the tanks. Cover the opening of the tank cover with a dust cloth.



For the battery, you should keep charging as per the instruction in the clause <battery maintenance and charging> even though the battery is disassembled from the machine.

16. Ensure the clean water tank is clean. Cumulation may cause a blockage. Clean the filter weekly to ensure the water pipe expedite when in operation (see figure 13)

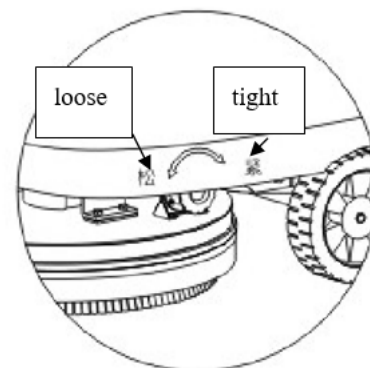

Figure 13

MAINTENANCE AND CHARGE OF BATTERY

This machine is battery-powered and thus the quality of the battery will directly affect the function of the machine. Please use the battery recommended by our company or other high-quality power batteries.

(Never use any automotive battery.)

In order to adapt itself to the requirements of various working conditions, battery 12V×2/100AH can be used in this machine. Please choose proper batteries according to your demands. Except for the difference in capacity, the batteries can be classified in two main categories: maintenance battery and maintenance-free battery according to their nature.

As an open type battery, a great deal of vapor bubbles will be produced when charging the maintenance battery. Therefore, the battery chamber cover should be taken off every time it is being charged. The liquid height of the electrolyte should be often checked. If it is lower than a specified height, distilled water should be added in time.

MAINTENANCE AND CHARGE OF BATTERY (CONT.)

(No mineral water, tap water or plain boiled water; never add any electrolyte arbitrarily). The maintenance battery is characterized by simple operation, moderate price and high price, and can have a very good performance ratio if maintained in good condition.

While using the maintenance-free battery, it is unnecessary for you to add liquid for its sealed structure. Yet because of its precision, the operator should pay more attention to the details in daily use. In case any mistake has been made, it will cause great economic losses. Though it is unnecessary to take the cover off when charging the maintenance-free battery, the specified or configured charger must be in use. If the charger designed for the common maintenance battery is used for charging maintenance-free battery, it could explode. The maintenance-free battery is characterized by strict structure, non- electrolyte leakage, without adding liquid, longer life than maintenance battery and high price. Furthermore, the operator should pay more attention to the details in its daily use. Any minor mistake will cause great losses. Therefore, it requires the operator to be better informed or educated in operation.

Whether you choose the battery recommended by our company or one bought by yourself, you should instruct your employees to pay more attention to the following cautions:

1. The added distilled water shall not exceed the upper limit line. If the electrolyte is too full, it will overflow through the holes in the battery cover. With the characteristic of conducting electricity, the circuit self discharge will be formed in case the electrolyte flows between the positive plate and negative plate. In this situation, the electrolyte should be wiped off or be washed by boiled water.
2. Resist rust: Besides checking whether it is installed firmly, pay more attention to the oxide and sulfate produced by the battery clip. After cleaning the rust, Vaseline may be applied to resist rust.
3. Cleaning: Keep the battery exterior clean. Always clean the dust and dirt on the battery cover, as well as the overflowed electrolyte. This will help to avoid self-discharging.
4. The liquid height of the electrolyte: the performance of the battery can be ensured only by remaining the normal liquid height of the electrolyte.
5. In low temperature: when this machine enters the low-temperature zone, full discharging of the battery should be avoided. The charging rate in low temperature will become slow.
6. Discharge: this machine uses a microcomputer to monitor the discharging of the battery. When the discharge is lower than the specified scale, the red light may turn on to alarm the operator. At that time, the battery should be charged as soon as possible.
7. If the machine is stored for over 30 days, its battery will be charged every 20-45 days; otherwise the battery may be damaged.
8. Remember to charge the battery after finishing the work. Keeping the battery at full capacity will help to prolong the lifespan of the battery.

9. Please use the specified charger to charge the battery. The output voltage of the charger should be matched with the specified voltage of the battery, and the rated current should be matched with the capacity of the battery. Any mismatch between them may cause damages of the battery or charger.
10. Notice: If the charger designed for a maintenance-free battery is used for charging the maintenance battery, the maintenance battery lifespan will be probably be shortened for long-term undercharge. If the charger designed for a maintenance battery is used for charging the maintenance-free battery, the maintenance-free battery could exploded.

Battery Maintenance Tips

1. Take care of the electrolyte volume when using a maintenance battery. It's necessary to avoid the exposing the polarities to the air or it will cause injury to the electric volume and the battery lifetime.
2. Check electrolyte volume one time per week in summer, one time per month in winter.
3. When left unused, continue to charge the battery one time per month or it will cause battery damage.
4. Try to charge the battery when the red light is on. Continuously charging the battery when it's not dead will hurt the battery stability.
5. If the machine has the above problem, please correct the way its used. It could help to charge and discharge after using 3-5 times. If the problem is still there, please do a "deep discharge," only turn on the brush or squeegee, charge until the red light flickers. Usually, this would help after 3 cycles.
6. Hang up the dirty water tank(see figure 14). It is best to keep the charger from laying directly on the ground. You can put it on a wall holder (see figure 15), which is good for ventilating and keeping dry. Ensure the battery has good heat dissipation.

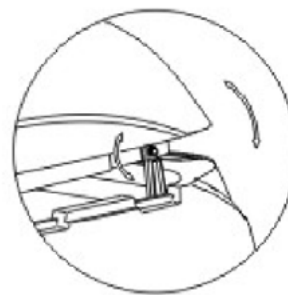

Figure 14

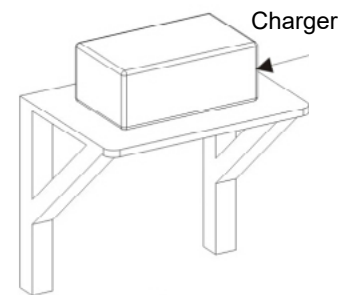
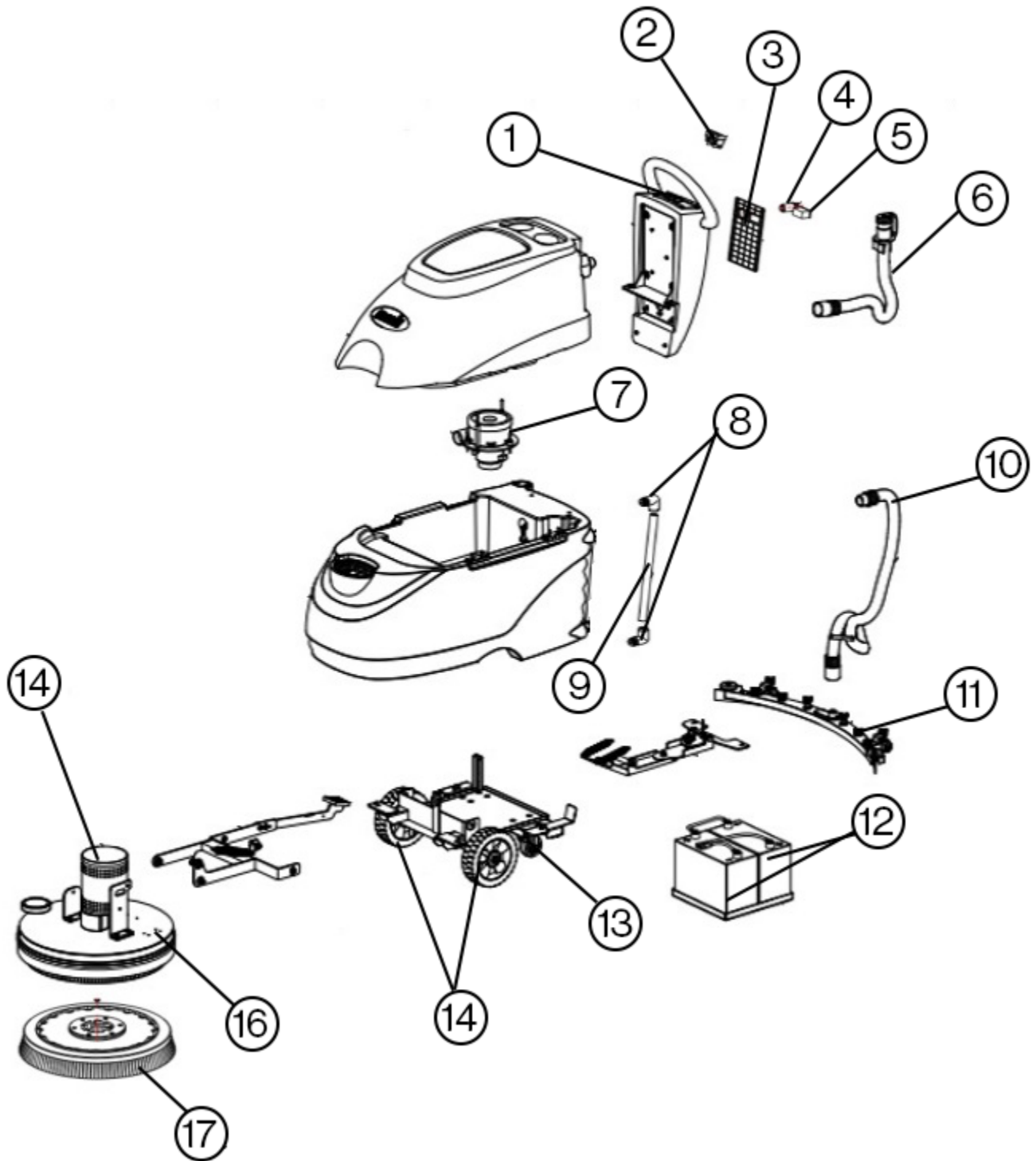

Figure 15

TROUBLESHOOTING

TROUBLES	POSSIBLE REASONS	TROUBLESHOOTING
The machine won't start	<ul style="list-style-type: none"> ■ Fuse is blown; ■ Not enough battery power; ■ Power cord plug is loose; ■ Switch is broken 	<ul style="list-style-type: none"> ■ Replace the fuse; ■ Charge or replace the battery; ■ Check the power connection; ■ Replace the switch
Brush won't rotate	<ul style="list-style-type: none"> ■ Not enough battery power; ■ Power cord plug is loose; ■ Switch is broken ■ Debris in the brush head 	<ul style="list-style-type: none"> ■ Check the power connection; ■ Replace the switch ■ Clean the debris
The suction motor won't work	<ul style="list-style-type: none"> ■ Not enough battery power; ■ Power cord plug is loose; ■ Switch is broken 	<ul style="list-style-type: none"> ■ Check the power connection; ■ Replace the switch
No water came out when cleaning	<ul style="list-style-type: none"> ■ The solution tank is empty ■ The hose is blocked ■ The water adjustment knob is closed ■ The valve is broken 	<ul style="list-style-type: none"> ■ Add water and detergent in solution tank ■ Clean the blockage ■ Turn the knob ■ Replace the valve
The suction power is low when cleaning	<ul style="list-style-type: none"> ■ Sealed circle and sealed strip are broken ■ There is debris or a broken area in the squeegee strip ■ The filter sponge is blocked ■ The cover of recovery tank is not closed properly 	<ul style="list-style-type: none"> ■ Replace the sealed circle and strip ■ Clean the squeegee strip or replace it ■ Clean the filter sponge ■ Close the recovery tank cover firmly
Leakage when machine is turned off	<ul style="list-style-type: none"> ■ The valve could be blocked by debris 	<ul style="list-style-type: none"> ■ Increase the water flow button, clean the debris out of the valve

PARTS AND DIAGRAMS



PARTS AND DIAGRAMS

ITEM NO.	PART NUMBER	DESCRIPTION	QTY.
1	DP-SCRUB-CNTRLBX	Control Box for DiamoPro Scrub 20	1
2	DP-SCRUB-BTTN	Button for DiamoPro Scrub 20	1
3	DP-SCRUB-PNL	Power Switch Panel for DiamoPro Scrub 20	1
4	DP-SCRUB-ISWK	Ignition Switch for DiamoPro Scrub 20	1
5	DP-SCRUB-HRMTR	Hour Meter for DiamoPro Scrub 20	1
6	DP-SCRUB-DRNHSE	Drain Hose for DiamoPro Scrub 20	1
7	DP-SCRUB-SCTNMTR	Suction Motor for DiamoPro Scrub 20	1
8	DP-SCRUB-LBW	Quick Connect Elbow for DiamoPro Scrub 20	2
9	DP-SCRUB-WTRPPE	Water Pipe for DiamoPro Scrub 20	1
10	DP-SCRUB-SCTNHSE	Water Suction Hose for DiamoPro Scrub 20	1
11	DP-SCRUB-SQGASSMBLY	Complete Squeegee Assembly for DiamoPro Scrub 20	1
12	DP-SCRUB-BTTRY	Battery for DiamoPro Scrub 20	2
13	DP-SCRUB-CSTR	Caster for DiamoPro Scrub 20	2
14	DP-SCRUB-WHL	Wheel for DiamoPro Scrub 20	2
15	DP-SCRUB-BRSHMTR	Brush Motor for DiamoPro Scrub 20	1
16	DP-SCRUB-PDDRVR	Pad Driver for DiamoPro Scrub 20	1
17	DP-SCRUB-FRNTBRSH	Front Brush for DiamoPro Scrub 20	1
NP	DP-SCRUB-SQGFBLD	Front Squeegee Blade for DiamoPro Scrub 20	1
NP	DP-SCRUB-SQGRBLD	Rear Squeegee Blade for DiamoPro Scrub 20	1
NP	DP-SCRUB-INLNFLTR	Inline Filter for DiamoPro Scrub 20	1
NP	DP-SCRUB-BTTRYCHRGR	Battery Charger for DiamoPro Scrub 20	1
NP	DP-SCRUB-BRDRVHUB	Brush Drive Hub for DiamoPro Scrub 20	1

Customer Acknowledgment and Assumption of Responsibility for Modification to any Product.

Customer expressly acknowledges that modification of any equipment, machines, or other products purchased from Niagara Machine, Inc. ("Niagara"), including but not limited to DiamaPro Systems Products (collectively, "Products") through the attempted or actual use or misuse, adjustment, alteration, application of additional components, removal of provided components, repairs or attempted repairs by Customer (collectively, "Modifications") can lead to Product malfunction causing serious risks. Such risks include, but are not limited to, Product damage, bodily injury, death, or loss of or damage to property. Customer agrees that Customer is solely responsible for any Modifications Customer performs on any Product purchased from Niagara, and that Niagara is not responsible and will not be held liable for any claims, damages, or injury arising from Modifications by Customer, including Customer's employees, subcontractors, agents, representatives, affiliates, and assigns, to any Product purchased from Niagara. Customer further acknowledges and agrees that any Modification(s) to a Product may, at DiamaPro Systems' and/or Niagara's election, void any warranty applicable to the Product.

Customer agrees that, to the greatest extent permitted by law, Customer shall indemnify, hold harmless and, at Niagara's request, defend (with counsel reasonably approved by Niagara), Niagara, Niagara's parent, subsidiaries, affiliates and the officers, directors, employees and agents of Niagara (individually and collectively "Niagara Indemnitees") from and against, and pay or reimburse them for any and all third-party claims, losses, damages, liabilities, lawsuits and expenses (including reasonable attorneys' fees) relating to bodily injury, death, or loss of or damage to property caused by or arising from any Modification to a Product by Customer, its employees, subcontractors, agents, representatives, affiliates, and assigns (individually and collectively, "Customer Group"), with respect to the Products Customer purchases from Niagara.

Customer acknowledges that Customer has read and understands these terms, and voluntarily assumes full and sole responsibility for any and all effects arising from any Modification to a Product by Customer Group.



DiamaPro®

SYSTEMS

DiamaPro® Systems
3343 Peachtree Road NE
Suite 145 #24
Atlanta, GA 30326
470-977-2323