



Diamapro[®]
SYSTEMS

OWNER'S MANUAL

SCAR-10

10" GAS OR PROPANE SCARIFIER



USER & MAINTENANCE BOOK

SAVE THESE INSTRUCTIONS FOR FUTURE REFERENCE



WARRANTY REGISTRATION CARD

Form must be completed and submitted within 30 days from the date of purchase.

Customer Information

First and Last Name

Company Name

Address

City

State

Zip Code

Phone Number

Email

Machine Information

Machine Type

Machine Model

Serial #

Purchase Date (dd/mm/yy)

Diamapro® Systems
3343 Peachtree Road NE
Suite 145 #24
Atlanta, GA 30326

470-977-2323 ■ www.diamaprosystems.com ■ info@diamaprosystems.com

INTRODUCTION

Thank you for purchasing a DIAMAPRO® SYSTEMS product. This manual provides information and procedures to safely operate and maintain the DiamaPro® SCAR-10. For your own safety and protection from injury, carefully read, understand, and observe the safety instructions described in this manual. Keep this manual or a copy of it with the machine. If you lose this manual or need an additional copy, please contact DiamaPro® Systems. This machine is designed and built with user safety in mind; however, it can present hazards if improperly operated and serviced. Please follow the operating instructions carefully. If there are any questions regarding operating or servicing of this machine, please contact DiamaPro® Systems.

Disclaimer: DiamaPro® Systems and its affiliates take no responsibility for any damage, injury or death resulting from the incorrect or unsafe use of this product. Use of this product should be undertaken by competent persons only. It is the operator's responsibility to ensure that the following safety procedures are followed. If you are unsure, do not operate this product.

SAFETY INSTRUCTIONS



READ & UNDERSTAND THE OPERATOR'S INSTRUCTION MANUAL THOROUGHLY BEFORE ATTEMPTING TO OPERATE THIS EQUIPMENT.

Death or serious injury could occur if this machine is used improperly.



Do not disconnect power by pulling cord. To disconnect, grasp the plug, not the cord.

- Safety Instructions are preceded by a graphic alert symbol of DANGER, WARNING, or CAUTION.



Indicates an imminent hazard which, if not avoided, will result in death or serious injury.



Indicates an imminent hazard which, if not avoided, will result in death or serious injury.



Indicates hazards which, if not avoided, could result in serious injury and/or damage to the equipment.

GASOLINE/PROPANE POWERED EQUIPMENT



- Gasoline is extremely flammable and poisonous. It should only be dispensed in well ventilated areas, and with a cool engine.

Warning: Engine exhaust from this product contains chemicals known to the State of California to cause cancer, birth defects or other reproductive harm.

Small gasoline engines produce high concentrations of carbon monoxide (CO) example: a 5HP 4 cycle engine operation in an enclosed 100,000 cu. ft. area with only one change of air per hour is capable of providing deadly concentrations of CO in less than fifteen minutes. Five changes of air in the same area will produce noxious fumes in less than 30 minutes. Gasoline or propane powered equipment should not be used in enclosed or partially enclosed areas. Symptoms of CO poisoning include, head-ache, nausea, weakness, dizziness, visual problems and loss of consciousness. If symptoms occur - get into fresh air and seek medical attention immediately.

CALIFORNIA PROP 65 WARNING

Thank you for purchasing a DIAMAPRO® SYSTEMS product. This manual provides information and procedures to safely operate and maintain the DiamaPro SCAR-10. For your own safety and protection from injury, carefully read, understand, and observe the safety instructions described in this manual. Keep this manual or a copy of it with the machine. If you lose this manual or need an additional copy, please contact DiamaPro® Systems. This machine is designed and built with user safety in mind; however, it can present hazards if improperly operated and serviced. Please follow the operating instructions carefully. If there are any questions regarding operating or servicing of this machine, please contact DiamaPro® Systems.



THIS PRODUCT CONTAINS LEAD, A CHEMICAL KNOWN TO THE STATE OF CALIFORNIA TO CAUSE BIRTH DEFECTS OR OTHER REPRODUCTIVE HARM.



THIS PRODUCT CONTAINS ONE OR MORE CHEMICALS KNOWN TO THE STATE OF CALIFORNIA TO CAUSE CANCER, BIRTH DEFECTS OR OTHER REPRODUCTIVE HARM.



EXHAUST GASES FROM THIS PRODUCT CONTAIN CHEMICALS KNOWN TO THE STATE OF CALIFORNIA TO CAUSE CANCER, BIRTH DEFECTS OR OTHER REPRODUCTIVE HARM.

CALIFORNIA PROP 65 WARNING

Use of this product can cause exposure to materials known to the State of California to cause cancer and/or birth defects or other reproductive harm.

WARNING

- ! Respirable crystalline silica. May cause cancer. Causes damage to lungs.
- Wear respiratory protection during exposure. Use appropriate dust control equipment to keep dust within OSHA and local regulation limits.



DUST WARNING

Cutting, especially when DRY cutting, generates dust that comes from the material being cut, which frequently contains silica. When dry cutting, be sure to use a HEPA filtered dust collector.

Silica is a basic component of sand, quartz, brick clay, granite and numerous other minerals and rocks. Exposure to excessive amount of such dust can cause:

- Respiratory diseases (affecting your ability to breath), including chronic bronchitis, silicosis and pulmonary fibrosis from exposure to silica. These diseases may be fatal;
- Skin irritation and rash; and
- Cancer according to NTP* and IARC*

*National Toxicology Program, International Agency for Research on Cancer

Take precautionary steps

- Avoid inhalation of and skin contact with dust, mist and fumes;
- Wet cut when feasible, to minimize dust;
- Wear and ensure that all bystanders wear appropriate respiratory protection such as dust masks designed to filter out microscopic particles. (See OSHA 29 CFR Part 1910.1200)

CARBON MONOXIDE WARNING

OPERATING ENVIRONMENT

The DiamaPro SCAR-10 can be operated outdoors within the temperature range of 41°F to 86°F (5°C to 30°C). It's crucial to avoid using the machine during rainy or snowy weather conditions. When using the machine indoors, make sure to work in areas that are adequately ventilated.

PROTECTION DEVICES

The machine is equipped with multiple safety mechanisms. These contrivances safeguard the operator and any other individuals from potential harm. It is imperative not to remove them. Instead, prior to utilizing the machinery, ensure that all safety devices are appropriately installed and operational.

USAGE SAFETY

The DiamaPro Systems SCAR-10 is intended to minimize all associated hazards related to its operation. Nonetheless, it is not entirely feasible to eliminate the possibility of accidents with the machine. Inexperienced or untrained operators may cause residual risks associated with:

- Positional hazards due to improper operator posture
- Entanglement hazards arising from the use of unsuitable work attire
- Training hazards caused by insufficient operational training

SAFETY MEASURES FOR PROPANE

Propane is a flammable gas with vapors that are denser than air. Similar to gasoline, improper handling of propane can lead to explosions. To aid in detecting leaks, propane is mixed with an odorant that has a distinctive smell, detectable at low concentrations. When working with propane, it is essential to be aware and take necessary safety precautions. As long as these measures are observed, the risk is minimal. However, lack of awareness could result in needless hazards. The two most significant dangers associated with propane-powered floor care machines are:

- Carbon Monoxide Poisoning:
Carbon monoxide poisoning is the most commonly reported incident associated with propane-powered floor care machines, caused by excessive exhaust emissions. The symptoms include headaches, dizziness, and nausea. Engines with inadequate preventive maintenance practices, particularly those with unclean air filters and machines operated in enclosed spaces without sufficient ventilation, are a significant cause. The use of substandard, inexpensive machines without emissions control technology and improperly adjusted carburetion could also contribute to the problem.
- Overfilled Fuel Cylinders:
Almost all fire-related incidents reported occur when a cylinder is brought into a building without first checking for overfill. This practice is hazardous, imprudent, and avoidable.

SAFETY AGAINST FIRE

Be mindful of the potential risks of fire or explosion when working with propane and take standard fire-safety measures.

- Fire:
There is a likelihood of fire resulting from leakage or venting of LPG vapor from fuel cylinders or carburetion equipment.
 - Explosion:
Concentration or confinement of LPG vapor in a restricted or small space may cause ignition or explosion.
- Propane may also experience a BLEVE: Boiling Liquid Expanding Vapor Explosion.

EMISSIONS

All propane-powered floor care machines generate emissions. While most are innocuous, some can be hazardous, even fatal. Carbon monoxide (CO) presents the most significant danger since exposure to CO at a concentration of 3,000 parts per million (ppm) for as little as 30 minutes can be lethal. Carbon monoxide is a colorless, odorless, and invisible gas formed when fossil fuels, including propane, gasoline, wood, coal, oil, and methane, burn incompletely.

AGENCIES AND REGULATIONS

■ National Fire Protection Agency (NFPA)

To operate a propane-powered floor care machine safely, it is necessary to adhere to specific safety regulations. The NFPA is responsible for ensuring safe propane use and storage, and their Standard for Storage and Handling of LP Gas should be consulted for guidance. Copies of this publication can be obtained by contacting the NFPA in Quincy, MA at 1-800-334-3555.

One important regulation set forth by the NFPA #58 is that all personnel who handle propane gas must be properly trained in its safe handling and operation procedures and carry a certification from their employer or training supervisor attesting to this fact. While this requirement primarily applies to individuals who fill and transport liquid propane gas, DiamaPro® Systems recommends that operators of propane-powered floor care machines in public areas also receive proper training and certification.

Although NFPA 58 8-4.5 permits the use of propane-powered floor care equipment in buildings frequented by the public, including when they are occupied, DiamaPro® Systems suggests that these machines be used when occupancy is minimal.

■ California Air Resource Board (CARB) & Environmental Protection Agency (EPA)

While CARB and EPA establish limits for propane-powered engines used outdoors, it is important to note that approval from CARB/EPA does not indicate that the engine is safe for indoor use.

■ Canadian Gas Association (CGA)

A limit of 1500 ppm CO in exhaust flow has been established by the CGA.

■ Occupational Health and Safety Administration (OSHA)

When it comes to propane-powered machines utilized indoors, OSHA has implemented an 8-hour time-weighted average (TWA) limit of 50 ppm CO in ambient air. OSHA is also contemplating the establishment of a limit of 800 ppm CO in exhaust flow.

■ Department of Transportation (DOT)

Regulations have been set forth by the DOT regarding the safety of fuel cylinders, including those utilized on propane-powered floor care machines.

■ Local Agencies

Before granting approval for the use of certain equipment, local law enforcement agencies such as the Fire Marshall may rely on independent testing laboratories like UL and CGA. These labs conduct extensive testing of equipment and only issue their approval after a rigorous evaluation process. While not mandatory for all law enforcement agencies, the stamp of approval from these organizations serves as an additional assurance for operators that they are working with and around safe equipment.

PERSONAL PROTECTIVE EQUIPMENT

When operating the machine, it is important to:

- Wear safety shoes at all times.
- Wear ear protectors to safeguard your hearing.
- Ensure that all personnel in the immediate work area wear safety glasses with side shields.
- Wear safety gloves when changing tools.
- Dress appropriately for the work environment.
- Use Carbon Monoxide monitors as an additional precaution.

TESTING:

Numerous tools are available in the market for detecting toxic gases. However, only the ones specifically designed for detecting carbon monoxide resulting from combustion engines are deemed suitable for testing exhaust emissions from floor machines powered by propane. Certain instruments are meant for detecting "ambient air" and may get damaged if utilized for taking readings in the muffler or tailpipe. Hence, it is crucial to select the appropriate instrument to fulfill the testing requirements. In general, instruments that can detect readings in ppm (parts per million) ranging from 0 to 1000 are sufficient for examining ambient air, i.e., the air in the breathing zone of the operator. On the other hand, devices capable of testing carbon monoxide in the exhaust should be certified by the manufacturer for that purpose and should be able to read from 0 to at least 2000 ppm.

Several instruments and systems for these purposes include:

1. AMBIENT AIR MONITORING

- DRAGER Model 190 manufactured by National Drager
- SENSIDYNE gas sampling system with YB-11038 Sensidyne detector tubes
- DRAGER gas sampling system with YB-4620 Drager detective tubes
- GAS-TECH Model CO-95
- ENERAC POCKET 60 manufactured by Energy Efficiency System

2. ENGINE EXHAUST ANALYZERS

- HORIBA GAS ANALYZER
- ENERAC 2000 COMBUSTION ANALYZER
- ENERAC POCKET 60

3. DATA LOGGERS

- INDUSTRIAL SCIENTIFIC CORP. MODEL STX-70 CO MONITOR, Data-Logger
- BIOSYSTEMS INC. "TEXILOG" Data-Logger

All instruments used for testing must be calibrated at the intervals recommended by the manufacturer. The test results must include the monitor's model number and date of calibration.

GENERAL INSTRUCTIONS

- Equipment should only be operated by trained personnel in good physical condition and mental health (not fatigued). The operator and maintenance personnel must be physically able to handle the bulk weight and power of this equipment.
- This is a one person tool. Maintain a safe operating distance to other personnel. It is the operators' responsibility to keep other people (workers, pedestrians, bystanders, etc.) away during operation. Block off the work area in all directions with roping, safety netting, etc. for a safe distance. Failure to do so may result in others being injured by flying debris or exposing them to harmful dust and noise.
- This equipment is intended for commercial or industrial use only.
- For the operator's safety and the safety of others, always keep all guards in place during operation.
- Never let equipment run unattended.



- Personal Protection Equipment and proper safety attire must be worn when operating this machine. The operator must wear approved safety equipment appropriate for the job such as hard hat and safety shoes when conditions require. Hearing protection **MUST** be used (operational noise levels of this equipment may exceed 90db). Eye protection **MUST** be worn at all times.



Keep body parts and loose clothing away from moving parts. Failure to do so could result in dismemberment or death.

- Do not modify the machine.
- Stop motor/engine when adjusting or servicing this equipment. Maintain a safe operating distance from flammable materials. Sparks from the cutting-action of this machine can ignite flammable materials or vapors.

SPECIFICATIONS

Horsepower	14 HP
Working Width	10 Inch
Working Depth	0- 5/16 Inch
Fuel	Propane
Gas / PropaneWeight	353 lbs / 370 lbs
Drum Rotation	Down Cut
Depth Control	Adjustable
Machine Size (L x H x W)	47 X 21 X 37 Inch

OPERATION INSTRUCTIONS

IMPORTANT!

Read the engine manufacturer's manual, familiarize yourself with engine start procedures.

BEFORE STARTING THE ENGINE:

Be sure that the cutter drum assembly has been properly installed and the cutter drum shaft is in place and secured.

- Select a level place at the job site. Set the "Handle Wheel" in the full counter-clockwise or UP position.
It is most important to determine the position of the cutter wheels as they relate to the slab or floor surface. If the drum assembly is filled with cutters, the cutter wheels will most likely contact the slab when the "Handle Wheel" turned clockwise or down.
Pull the "Engagement Handle" towards the operator to ensure the cutting drum will not contact the slab when attempting to start the machine. Always raise the Engagement Handle before starting the machine to prevent accidental damage to the machine and the slab.
- Turn the "Handle Wheel" to the full counter-clockwise position and raise the machine. **DO NOT** force the handle wheel. If resistance is felt, turn the "Handle Wheel" clockwise one or two turns. This will allow the "Handle Wheel" to reach its normal full UP position.
- Check level of oil in engine crankcase (engines are usually shipped dry, oil must be added as per engine manufacturers instructions).
- Check fuel level (follow engine manufacturers instructions).
- Be sure all guards (belt, motor, cutter wheel) are in place and secure.
- Be sure the emergency stop switch is fully seated and attach the end of the cord to a secure piece of clothing before operation
- Raise the throttle about half way and turn the ignition key clockwise to start the machine.
- If utilizing the pull starter, determine the starter rope pulls easily, and the rope retracts properly.

BEFORE STARTING THE MACHINE

- Perform a visual inspection of the entire machine and all daily maintenance according to the Maintenance Schedule.
- Locate and be familiar with all engine/motor and operating controls.
- For Gasoline models, obtain the Engine Manufacturer's Owner's Manual. Read it and understand it before continuing. Follow the engine manual for break-in instructions.
- Use the correct cutters for the job. Be sure cutter drum is balanced, the number, size and type of cutter wheels are correct and the cutter drum shaft is locked and secured.
- Be sure all fasteners are tight and secure, check for signs of metal cracking or fatigue, inspect for damage to electrical wiring, damage to fuel lines, check bearings, etc.
- Be sure all guards are in place. Do not operate unless cutter drum guard is in place and secure.
- Inspect work area to determine the presence and location of deck inserts, pipes, columns and objects protruding from the slab surface so that they may be avoided during operation.

STARTING THE ENGINE/MOTOR



DO NOT OPERATE GASOLINE/PROPANE POWERED EQUIPMENT WITHOUT ADEQUATE VENTILATION. CARBON MONOXIDE IS AN INVISIBLE, ODORLESS GAS THAT CAN KILL.

- Consult the Engine Manufacturer's Owner's Manual and follow the directions for starting the engine and allow the engine to warm up.



NEVER CHECK FOR PROPANE LEAKS USING AN OPEN FLAME. INSTEAD, USE A LEAK-TESTING SOLUTION. NEVER ALLOW PROPANE FUMES TO ESCAPE IN A CLOSED AREA; PROPANE IS HEAVIER THAN AIR AND WILL "SETTLE."

- To start this propane powered equipment, open the main fuel valve located on the propane tank. Open the throttle wide open and start the engine.

NOTE: Always turn off the main fuel valve on the propane tank when equipment is not being used.



ALWAYS BE SURE TO UTILIZE THE SAFETY STOP SWITCH AND FASTEN THE STOP SWITCH LEAD TO A SECURE PIECE OF CLOTHING.

OPERATION INSTRUCTIONS (cont).

STARTING THE CUT

- Slowly lower the cutter head to the slab surface with the engagement handle
- When cutting, be sure to engage the handle wheel lock. This will ensure the depth of cut does not change due to vibrations.
- Rotate the Depth Control down until you hear the cutters contact the slab. Once contact is made lower the machine an additional 1/8" for the initial pass. Additional passes can be made in 1/8" increments to a maximum depth of 3/8".
Cutting more than 1/8 per pass could result in damage to the drum and machine.
- Use an Industrial Vacuum Dust Control System for dry planing operations.

TO STOP CUTTING

- Move engagement handle toward the operator to raise cutter head assembly above slab surface.
- For gasoline and propane models, close throttle and turn the ignition switch to the "OFF" position.

AFTER CUTTING

- At the end of the day, clean the entire machine after it has cooled. Check for worn or damaged cutters and perform any required maintenance.

CUTTING HEADS / DRUMS

- Drum assembly revolves at approximately 1200-1800 R. P. M.; Push Model Scarifier/Planer is a down-cut planer, Depth of cut is completely determined by the material to be cut, horsepower of the engine/motor and spacing of the cutter wheels on the cutter head.
- All cuts should be started from a stationary position - when the cutting depth is reached the planer should then move forward.
- The engine/motor should not labor. Run at full speed and adjust forward speed to fit the work being performed. Very hard concrete will have to be cut at a slower pace than asphalt or deteriorated surfaces.
- If it is necessary to make deep cuts - make several shallow cuts to achieve the desired depth. If the cutting depth is set too deep the cutter wheels will not be able to absorb the shock and damage to the equipment will result.
- The cutter wheels have an oversized arbor hole. This "play" is needed to absorb some of the shock of the cutter contacting the concrete.
- Cutting speed is directly proportional to the amount of material to be removed in one pass; an example - cutters spaced on 1" centers will penetrate to a greater depth than those spaced at 1/2" centers, and the planer will move forward faster. Most of the material in the path of the cutting head will be removed either by the cutters themselves or through the natural hammering action and spalling of the material being cut. A later pass with cutters spaced closer together will remove the ridges.

TO REACH MAXIMUM DEPTH IN CONCRETE

- It is best to make several passes - increments of 1/32-1/8" or even less if surface is extremely hard.
- Use coarse (wide spacing) for initial passes. Complete job with medium spacing. Never use a fine spaced cutter head to cut deeper than 1/32-1/8".
- Some concrete slabs, especially if they are covered with water a good deal of time or if they have been treated with hardeners, develop an extremely high surface strength.
Material removal depth should not exceed 1/32-1/8" per pass thus requiring several passes to reach the desired depth of cut.

TO CUT ASPHALT

- This surface can be easier to penetrate than concrete. In some instances depths of 1/4" per pass can be achieved with the larger machines. In general though, 1/8" per pass is still standard and should be maintained until the hardness of the asphalt is determined.

Note: Specific information on asphalt cutting is available upon request.

FINE CUTTING

- This assembly should be used for very shallow or cleaning operations. Check with DiamoPro® Systems or an authorized dealer for special cutter wheels for removal of paint build-up or similar surface coatings.

MAINTENANCE

Refer to the Engine/Motor Manufacturer's Owner's Manual for maintenance information specific to the engine/motor used.

CAUTION

Never work on or under equipment without first securing the equipment to prevent it from moving or falling. Always work on a flat and level surface.

IMPORTANT!

- Check oil level before operation. Change engine oil and filter according to engine manufacturers recommendations.
- Clean air filter element daily.

BELTS

On new equipment, and after replacing a set of belts, they should be re-tensioned after the first four hours of use.

- New belts will be stiff and will loosen with use. Proper belt tension must be maintained to transmit the engine/motor power to the cutting drum. Slipping belts will overheat, belt life will be shortened and the cutting speed limited.
Over tensioned belts will shorten belt and bearing life.
- Damaged, stretched or excessively worn belts should be replaced with a complete set. DO NOT mix new and used belts, doing so will only shorten the life of new belt(s) and limit power transfer from the engine/motor to the cutting drum. This will have a definite impact on machine efficiency and production rate.
- To tension belts, loosen motor mounting hardware slightly. Use the jacking bolt to adjust the engine/motor until the belts are tight. Re-torque the engine/motor mounting hardware.

CUTTER ASSEMBLY BEARINGS

- -Grease cutter assembly with one pump of a lithium complex grease (XHP222 or equivalent) after every 4 hours of use.

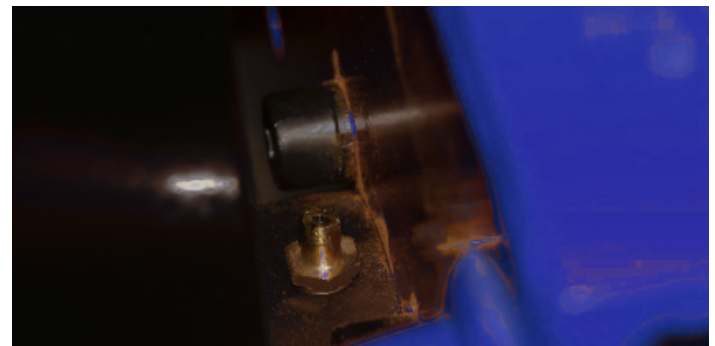

BLADES & DRUM REMOVAL/REPLACEMENT

CUTTING DRUM ASSEMBLY

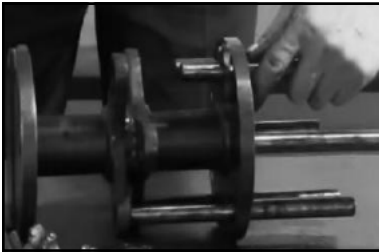

(A)

Pull the Cutting Disc Shafts out the open side of the Cutting Drum as shown.

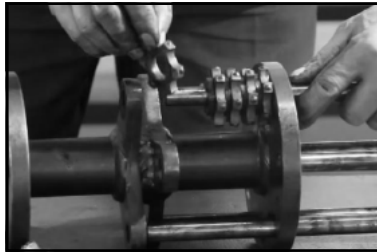

(B)

Assemble the Cutting Drum using Cutting Discs and Disc Spacers (See Cutting Drum Configuration).



(C)

Continue Step B until the Cutting Drum assembly is complete.

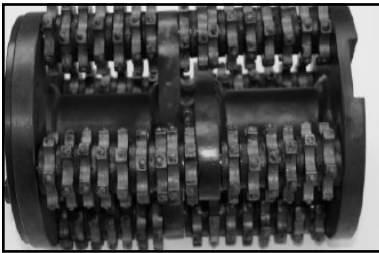

(D)

Place the Cutting Drum on the closed end, with the open end facing upward.



(E)

Obtain the Retaining Ring and Flat Washer Spacers.

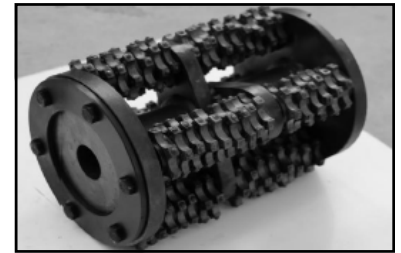

(F)

Install the 6 Flat Washer Spacers (if used) over the 6 Retaining Ring, Retaining Screw holes.

NOTE: The Cutting Drum may be disassembled from either end.

BLADES & DRUM REMOVAL/REPLACEMENT (cont.)

CUTTING DRUM INSTALLATION

1. Be sure the machine is turned off with the battery disconnected with the key switch in the off position. Remove the safety switch tether for added protection.
 - Engage the parking brake to ensure the machine does not move during this operation.

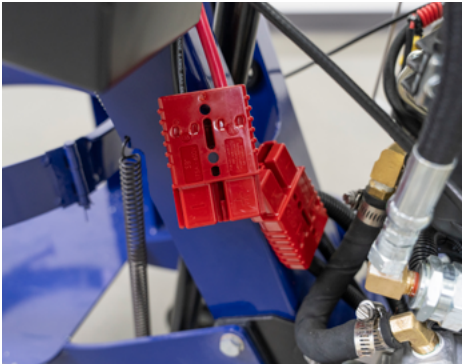

2. On the right side of the machine, opposite from the belted side, remove the bottom 2 socket head bolts from the bearing plate using an M10 Allen set.



3. Remove the top 2 bolts using an M18 Wrench.



BLADES & DRUM REMOVAL/REPLACEMENT (cont.)

4. To remove the plate from the machine, thread the 2 socket head bolts into the threaded holes on the left and right of the bearing plate.
Be sure not to cross-thread these holes.
■ Gently tighten the bolts one after another, a few turns at a time, to press the plate off of the shaft.



5. Slide the drum off of the shaft carefully, so as not to damage the shaft.
6. Set up your drum profile as desired.



7. Slide the new drum back onto the shaft. Be sure that the drum is fully seated onto the driving plate, and the spacer (A) is fully seated against the drum.

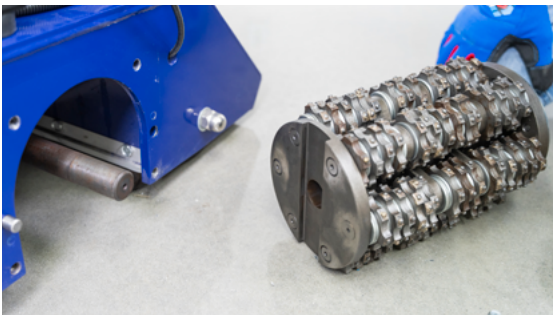

8. Using the guide pins (A), reattach the bearing plate to the machine using the bolts previously removed. Be sure the bearing is seated onto the shaft. It may be helpful to lower the machine so that the drum is touching the ground taking the load off the shaft allowing easier alignment of the holes.

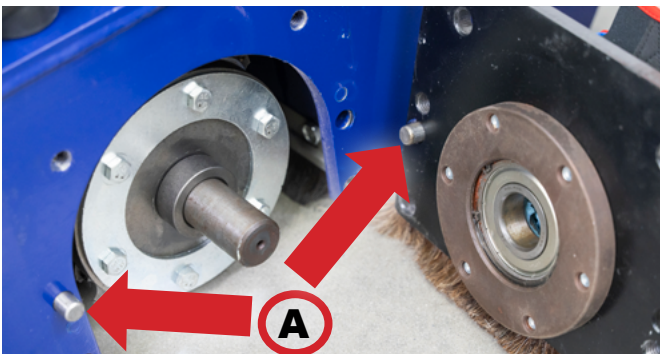

SCAR-10 PROPANE/GAS MAINTENANCE SCHEDULE

MAINTENANCE TASK	ALTERNATE	DAILY	WEEKLY
Inspect belts and belt tensions		x	
Warning stickers		x	
Inspect cutting drum		x	
Inspect machine for damage		x	
Clean machine		x	
Check bolt tightness on the machine		x	
Unplug battery from machine after use		x	
Check propane lines for wear		x	
Grease bearings	every 10 working hours	x	
Check engine oil		x	
Check air filter*		x	
Change engine oil	every 50 hours		x
Replace air filter	every 100 hours		x
Check engine wiring for wear/damage		x	
Check throttle cable			x

*NOTE: Air filter may need to be checked and replaced sooner if exposed to extremely dusty environments

SCARIFIER ACCESSORIES APPLICATION GUIDE KEY



Preferred method to produce maximum performance or productivity rates for most job applications



Acceptable performance or productivity rate for most job applications



Limited performance productivity rates for most job applications

<p>Drum Assembly</p>	 <p>60/4 (cutters/blade shaft)</p>	 <p>90/6 (cutters/blade shaft)</p>	 <p>90/6(cutters/blade shaft)</p>	 <p>110/6(cutters/blade shaft)</p>
-----------------------------	---	---	--	---

Applications

PREPARATION GUIDE	← LIGHT REMOVAL			HEAVY SCALING →
Removal of paints & coatings from tanks & deck areas				
Removal of non-slip paints, epoxies, mastics & rubberized coatings from steel tanks & deck areas				
Removal of heavy rust & scale build up in tanks & deck areas				
Removal of paint, dirt build up & ice deposits from concrete floors				
Roughing keying texturing concrete. Removal of laitance excess concrete or asphalt				
Removal of thermoplastic road, runway markings				
Sidewalk trip hazard repair				
Concrete grooving applications for non-slip surfaces				

DP-SCAR-10 MAIN ASSEMBLY

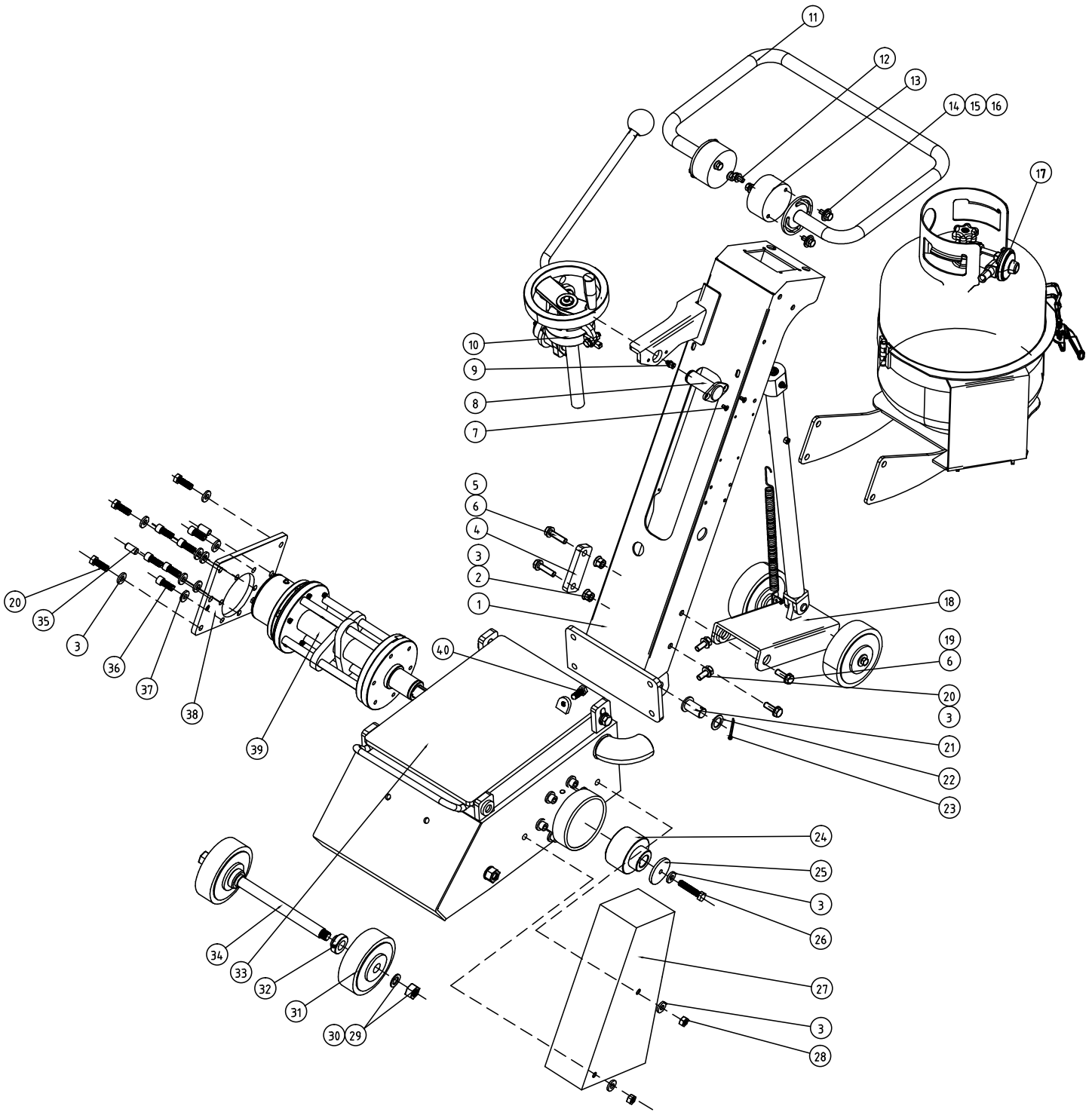

DP-SCAR-10 MAIN ASSEMBLY

ITEM #	DESCRIPTION	PART #	QTY
1	Handrail Bracket Assembly for DiamaPro 10" Scarifier	DP-SCAR10-HRBA	1
2	Outer Hexagonal Locknut for DiamaPro 10" Scarifier	DP-SCAR10-LM10	4
3	Washer for DiamaPro 10" Scarifier	DP-SCAR-SW10	15
4	Cushion Block for DiamaPro 10" Scarifier	DP-SCAR10-CBL	1
5	Outer Hexagonal Bolt for DiamaPro 10" Scarifier	DP-OHB-M10X40	2
6	Flat Washer for DiamaPro 10" Scarifier	DP-FLAT-10	4
7	Inner Hexagonal Bolt for DiamaPro 10" Scarifier	DP-IHB-M5X40	2
8	Rotary Mandrel for DiamaPro 10" Scarifier	DP-SCAR10-ROMD	1
9	Grease Nipple for DiamaPro 10" Scarifier	DP-SCAR10-GN10	1
10	Handle Screw Assembly for DiamaPro 10" Scarifier	DP-SCAR10-HDSA	1
11	Armrest for DiamaPro 10" Scarifier	DP-SCAR10-ARMR	1
12	Outer Hexagonal Bolt for DiamaPro 10" Scarifier	DP-OHB-M10X20	4
13	Armrest Cushion for DiamaPro 10" Scarifier	DP-SCAR10-ARMSC	2
14	Outer Hexagonal Bolt for DiamaPro 10" Scarifier	DP-OHB-M8X20	4
15	Washer for DiamaPro 10" Scarifier	DP-SCAR10-WS8	4
16	Large Washer for DiamaPro 10" Scarifier	DP-SCAR10-LGWS8	4
17	Propane Tank Holder Assembly for DiamaPro 10" Scarifier (Propane Units Only)	DP-SCAR10-GTHA	1
18	Rear Wheel Frame Assembly for DiamaPro 10" Scarifier	DP-SCAR10-RWFA	1
19	Outer Hexagonal Bolt for DiamaPro 10" Scarifier	DP-OHB-M10X30	2
20	Outer Hexagonal Bolt for DiamaPro 10" Scarifier	DP-OHB-M10X25	8
21	Small Chassis Swing Pin Shaft for DiamaPro 10" Scarifier	DP-SCAR10-SCPS	2
22	Flat Washer for DiamaPro 10" Scarifier	DP-SCAR10-WS20	2
23	Cotter Pin for DiamaPro 10" Scarifier	DP-SCAR10-CP2.5	2
24	Shaft Pulley for DiamaPro 10" Scarifier	DP-SCAR10-DRPL	1
25	Large Washer for DiamaPro 10" Scarifier	DP-SCAR10-LGWS10	1

DP-SCAR-10 MAIN ASSEMBLY (cont.)

ITEM #	DESCRIPTION	PART #	QTY
26	Outer Hexagonal Bolt for DiamaPro 10" Scarifier	DP-OHB-M10X125X30	1
27	Belt Cover for DiamaPro 10" Scarifier	DP-SCAR10-BTCV	1
28	SS Cap Nut for DiamaPro 10" Scarifier	DP-CNUT-M10	2
29	Flat Washer for DiamaPro 10" Scarifier	DP-FLAT-16	2
30	SS Cap Nut for DiamaPro 10" Scarifier	DP-CNUT-M16	2
31	Rubber Wheel for DiamaPro 10" Scarifier	DP-SCAR10-RWHL	2
32	Locker Cover for DiamaPro 10" Scarifier	DP-SCAR10-LCVR	2
33	Main Box for DiamaPro 10" Scarifier	DP-SCAR10-MNBX	1
34	Front Wheel Shaft for DiamaPro 10" Scarifier	DP-SCAR10-FWSH	1
35	Locating Pin for DiamaPro 10" Scarifier	DP-SCAR10-LP12	2
36	Inner Hexagonal Bolt for DiamaPro 10" Scarifier	DP-IHB-M10X25	12
37	Spring Washer for DiamaPro 10" Scarifier	DP-SCAR10-SW101	12
38	Plate for DiamaPro 10" Scarifier	DP-SCAR10-PLATE	1
39	Drum Assembly for DiamaPro 10" Scarifier	DP-SCAR10-DRUM	1
40	Outer Hexagonal Bolt for DiamaPro 10" Scarifier	DP-OHB-M10X55	1
NP	Engine for DiamaPro 10" Scarifier	DP-SCAR10-14HP	1
NP	Deflector Muffler for DiamaPro 10" Scarifier	DP-SCAR10-7816	1
NP	Air filter for DiamaPro 10" Scarifier	DP-SCAR10-AIRF	1
NP	Muffler for DiamaPro 10" Scarifier	DP-SCAR10-7815	1
NP	Driving Pulley for DiamaPro 10" Scarifier	DP-SCAR10-DNPL	1
NP	Belt for DiamaPro 10" Scarifier	DP-SCAR10-BELT	1

TANK BRACKET ASSEMBLY (Propane Units Only)

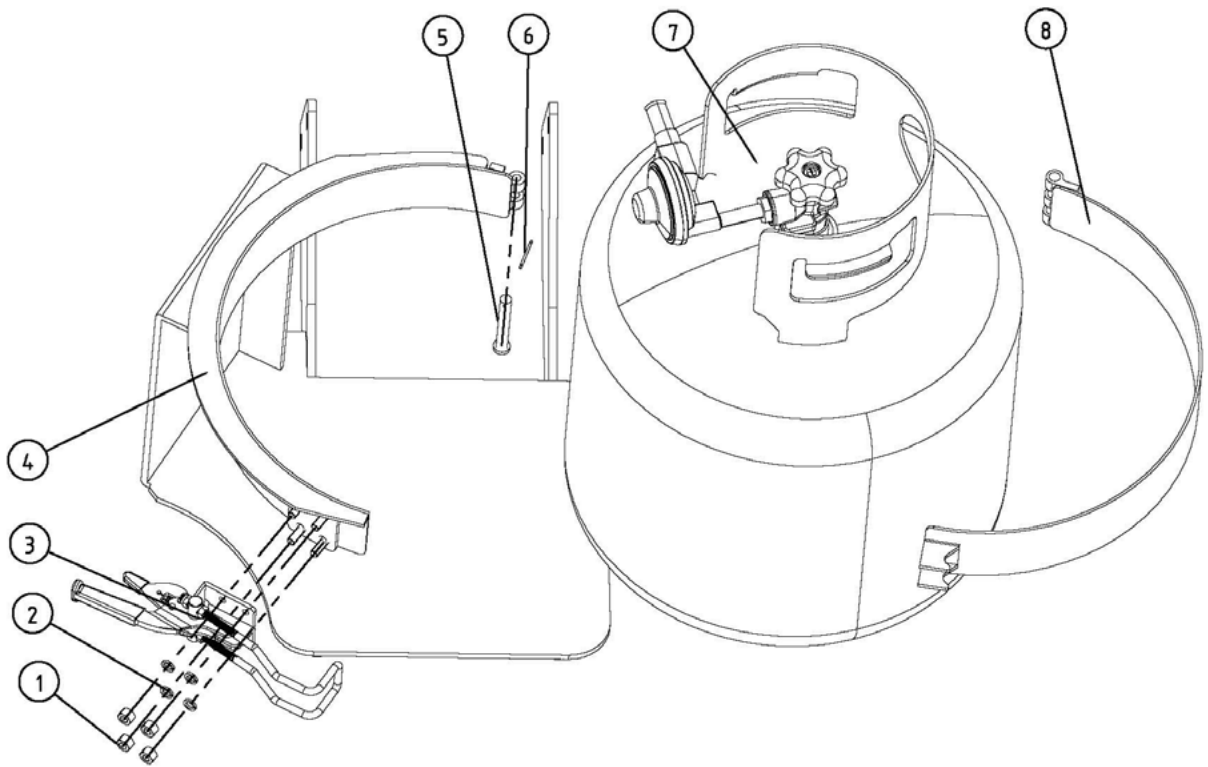

ITEM #	DESCRIPTION	PART #	QTY
1	Outer Hexagonal Nut for DiamaPro 10" Scarifier	DP-NUT-M6	4
2	Spring Washer for DiamaPro 10" Scarifier	DP-SCAR10-SW6	4
3	Clasp for DiamaPro 10" Scarifier	DP-SCAR10-CLSP	1
4	Propane Tank Holder for DiamaPro 10" Scarifier	DP-SCAR10-GTH	1
5	Hoop Pin Shaft for DiamaPro 10" Scarifier	DP-SCAR10-HPS	1
6	Cotter Pin for DiamaPro 10" Scarifier	DP-SCAR10-CP2X25	1
7	Steel Cylinder Vapor 20lb with Fill, All In One	VAPOR-TANK-STEEL-20#-B	1
8	Gas Tank Hoop for DiamaPro 10" Scarifier	DP-SCAR10-GTL	1

HANDLE SCREW ASSEMBLY

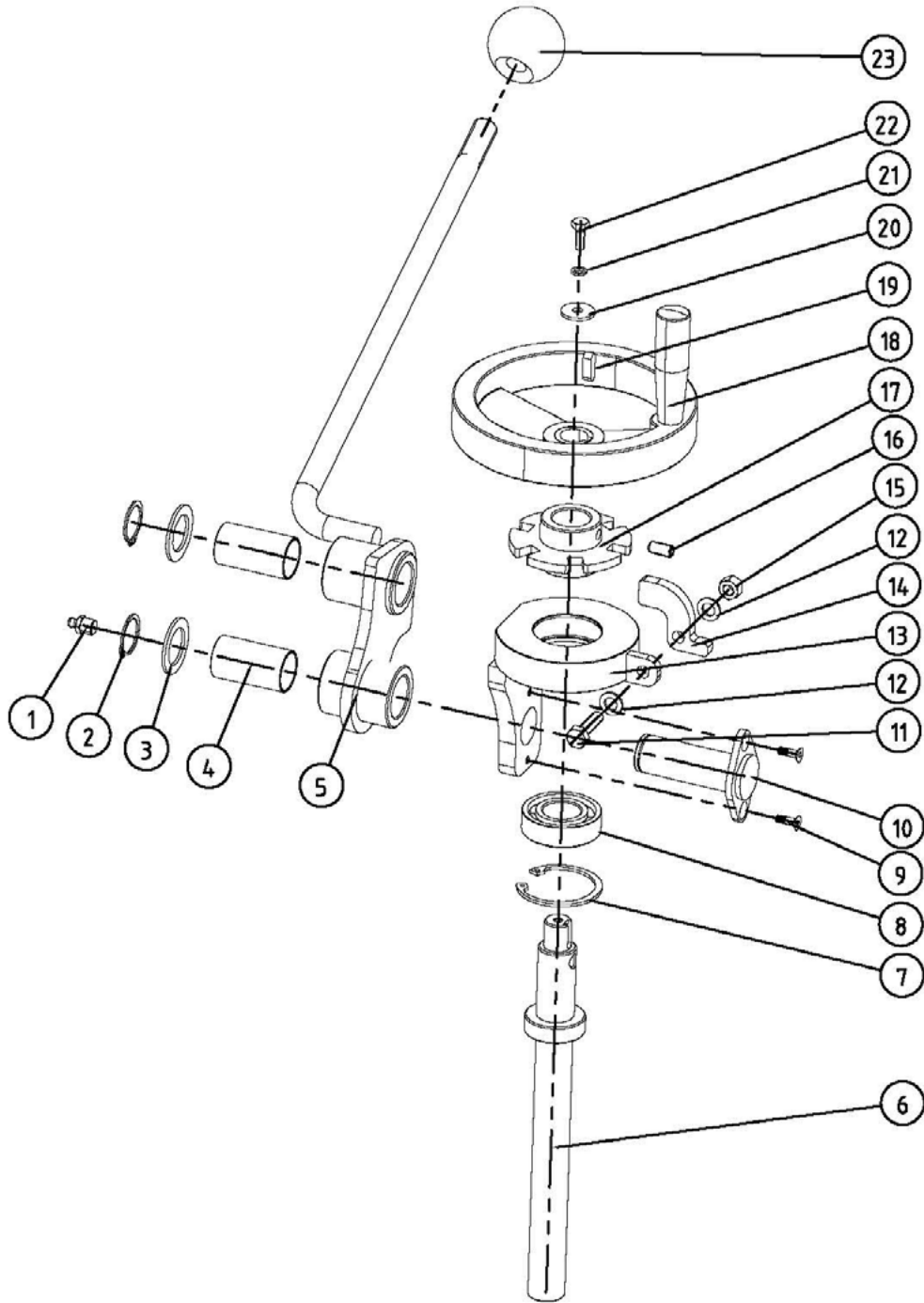

HANDLE SCREW ASSEMBLY

ITEM #	DESCRIPTION	PART #	QTY
1	Grease Nipple for DiamaPro 10" Scarifier	DP-SCAR10-GN10	1
2	C-Clip for DiamaPro 10" Scarifier	DP-SCAR10-CIRC25	2
3	Flat Washer for DiamaPro 10" Scarifier	DP-FLAT-25	2
4	Copper Sleeve for DiamaPro 10" Scarifier	DP-SCAR10-OFCS	2
5	Knob for DiamaPro 10" Scarifier	DP-SCAR10-KNOB	1
6	Adjustable Screw for DiamaPro 10" Scarifier	DP-SCAR10-ADSC	1
7	C-Clip for DiamaPro 10" Scarifier	DP-SCAR10-CIRC52	1
8	Deep Groove Ball Bearing for DiamaPro 10" Scarifier	DP-SCAR10-BB7205	1
9	Countersunk Bolt for DiamaPro 10" Scarifier	DP-CIHB-M5X12	2
10	Rotary Mandrel for DiamaPro 10" Scarifier	DP-SCAR10-ROTM	1
11	Hex Head Bolt for DiamaPro 10" Scarifier	DP-OHB-M8X30	1
12	Flat Washer for DiamaPro 10" Scarifier	DP-FLAT-8	2
13	Bearing Pedestal for DiamaPro 10" Scarifier	DP-SCAR10-BPW	1
14	Lock Block for DiamaPro 10" Scarifier	DP-SCAR10-LKBK	1
15	Locknut for DiamaPro 10" Scarifier	DP-SCAR10-LM8	1
16	Socket Head Set Screw for DiamaPro 10" Scarifier	DP-SCAR10-SSM8X12	1
17	Positioning Disk for DiamaPro 10" Scarifier	DP-SCAR10-PODI	1
18	Handle Wheel for DiamaPro 10" Scarifier	DP-SCAR10-HWHL	1
19	Flat Key for DiamaPro 10" Scarifier	DP-SCAR10-KEY6X20	1
20	Large Washer for DiamaPro 10" Scarifier	DP-SCAR10-LWS6	1
21	Spring Washer for DiamaPro 10" Scarifier	DP-SCAR10-SW6	1
22	Hex Head Bolt for DiamaPro 10" Scarifier	DP-OHB-M6X16	1
23	Ball Joint for DiamaPro 10" Scarifier	DP-SCAR10-BM16X50	1

REAR WHEEL FRAME ASSEMBLY

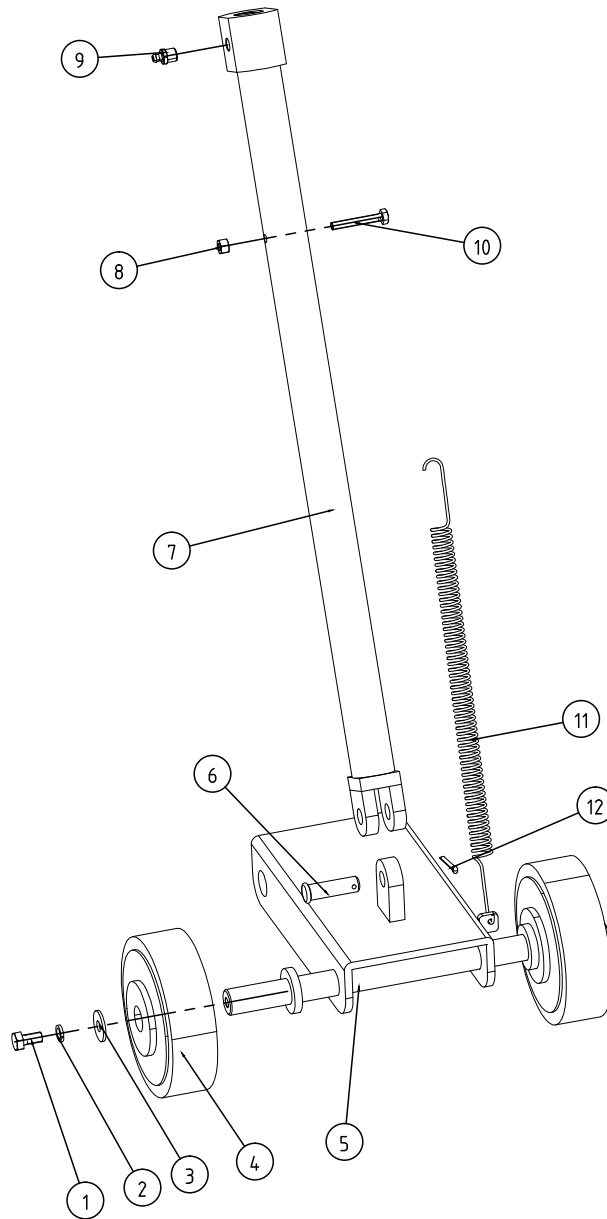

ITEM #	DESCRIPTION	PART #	QTY
1	Outer Hexagonal Bolt for DiamaPro 10" Scarifier	DP-OHB-M8X16	2
2	Spring Washer for DiamaPro 10" Scarifier	DP-SCAR10-SW8	2
3	Large Washer for DiamaPro 10" Scarifier	DP-SCAR10-LGWS8-1	2
4	Rubber Wheel for DiamaPro 10" Scarifier	DP-SCAR10-RWHL	2
5	Rear Wheel Frame for DiamaPro 10" Scarifier	DP-SCAR10-RWF	1
6	Lifting Rod Pin for DiamaPro 10" Scarifier	DP-SCAR10-LRP	1
7	Lifting Rod Pin Shaft for DiamaPro 10" Scarifier	DP-SCAR10-LRPS	1
8	Locknut for DiamaPro 10" Scarifier	DP-SCAR10-LNM6	1
9	Grease Nipple for DiamaPro 10" Scarifier	DP-SCAR10-GN10	1
10	Outer Hexagonal Bolt for DiamaPro 10" Scarifier	DP-OHB-M6X45	1
11	Spring for DiamaPro 10" Scarifier	DP-SCAR10-SPRG	1
12	Cotter Pin for DiamaPro 10" Scarifier	DP-SCAR10-CP	1

PARKING BRAKE ASSEMBLY

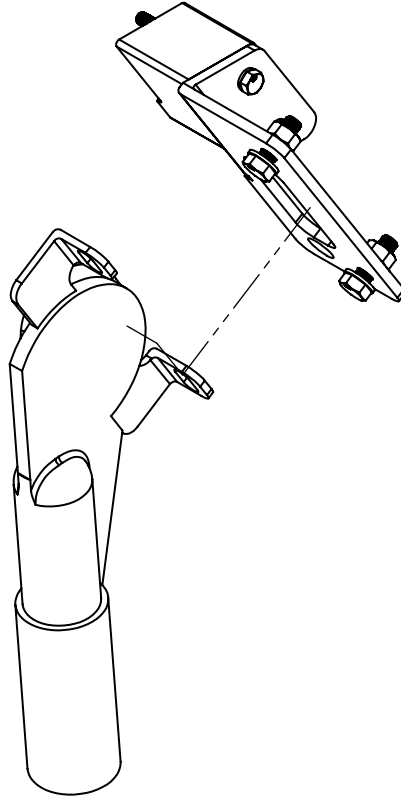

DESCRIPTION	PART #	QTY
Complete parking brake assembly for DiamoPro 10" Scarifier	DP-SCAR10-PBASM	1

CONTROL PANEL WIRING SHROUD ASSEMBLY

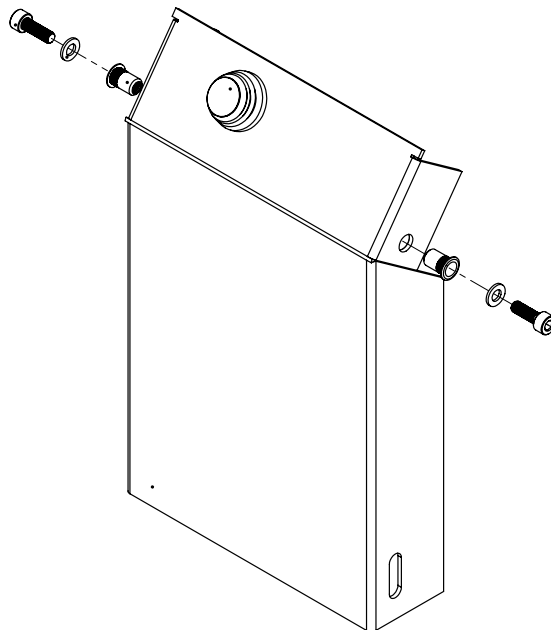

DESCRIPTION	PART #	QTY
Complete Control Panel Wiring Shroud Assembly for DiamoPro 10" Scarifier	DP-SCAR10-CPWSASM	1

REGULATOR BRACKET ASSEMBLY (Propane Units Only)

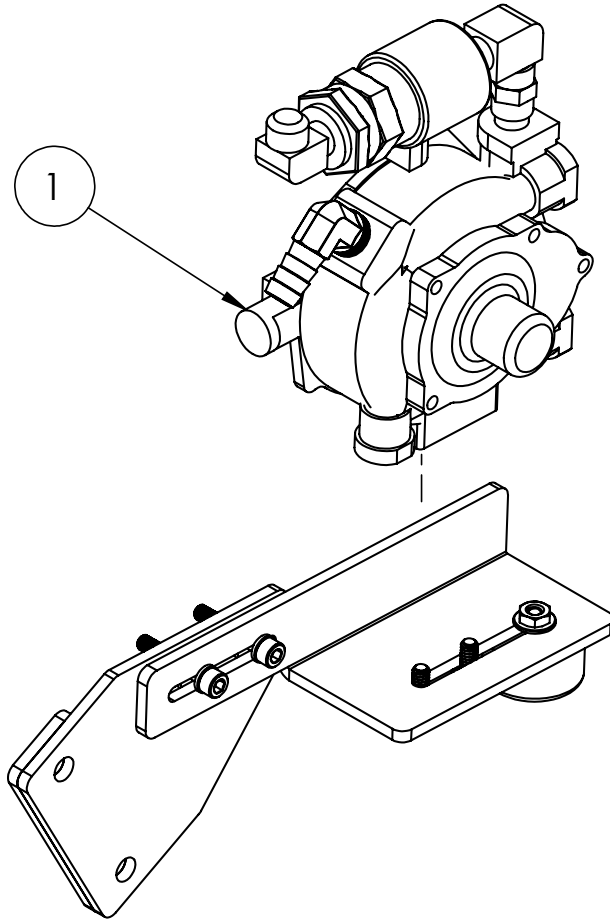

ITEM #	DESCRIPTION	PART #	QTY
	Main Assembly	DP-SCAR10-RBASM	1
1	Regulator for DiamoPro Scarifier	DP-SCAR10-REG	1
NP	Low Pressure Hose	DP-SCAR10-REGLH	1
NP	High Pressure Hose	DP-SCAR10-REGHH	1

FRONT WIRING SHROUD ASSEMBLY

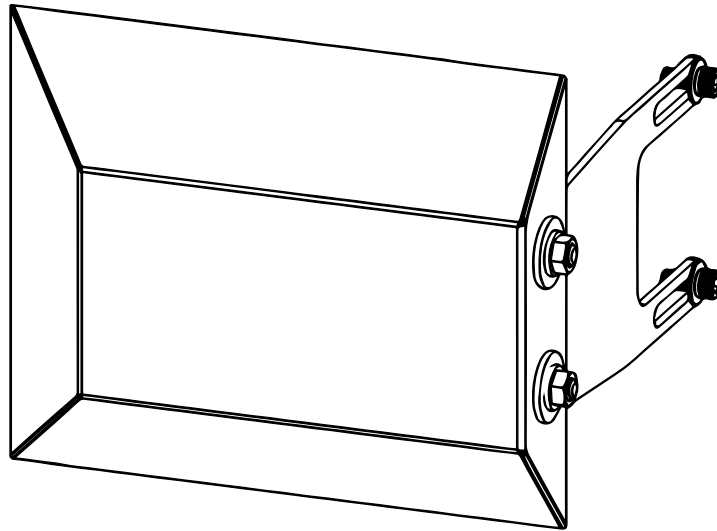

DESCRIPTION	PART #	QTY
Complete Front Wiring Shroud Assembly for DiamoPro 10" Scarifier	DP-SCAR10-FWSASM	1

THROTTLE ASSEMBLY

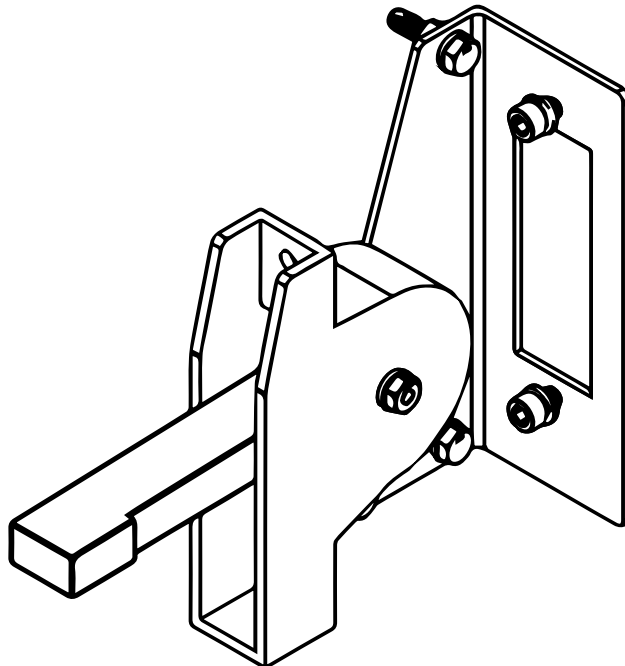

DESCRIPTION	PART #	QTY
Complete Throttle Assembly for DiamoPro 10" Scarifier	DP-SCAR10-THRASM	1

BATTERY BOX ASSEMBLY

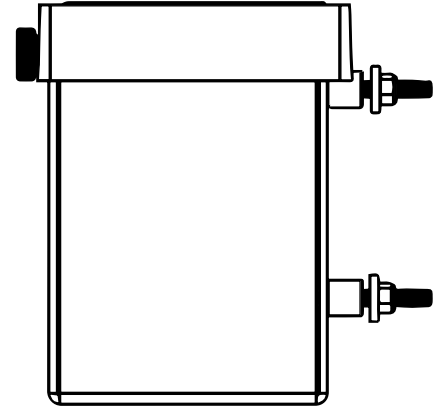
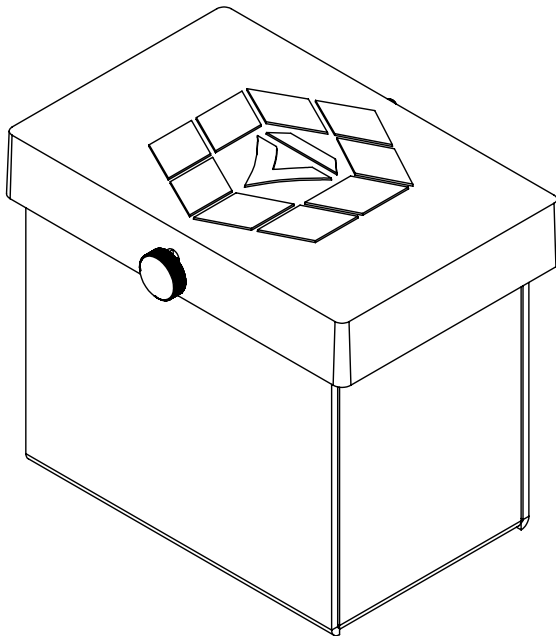

DESCRIPTION	PART #	QTY
Battery Box Main Assembly for DiamoPro 10" Scarifier	DP-SCAR10-BBASM	1
MBTX 12v12a Battery	W4359	1

HEADLIGHT ASSEMBLY (Propane Units Only)

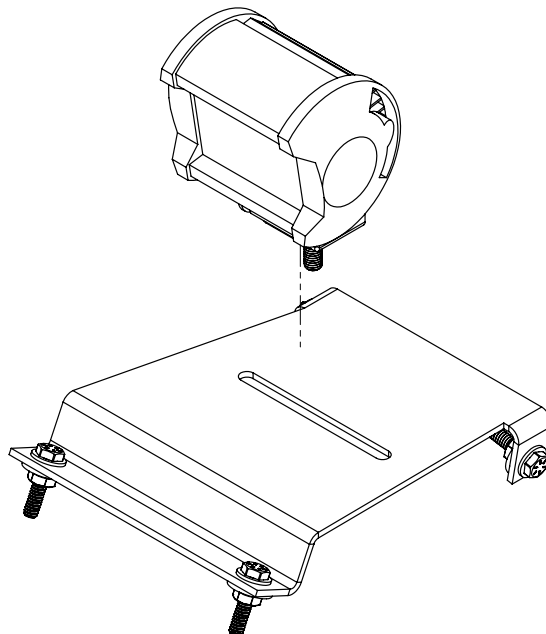

DESCRIPTION	PART #	QTY
Complete Headlight Assembly for DiamoPro 10" Scarifier	DP-SCAR10-HLASM	1

CONTROL PANEL (not pictured)

DESCRIPTION	PART #	QTY
Ignition Key Switch	ROG-60V2318	1
SAM Safe Air Monitor (Propane Units Only)	DP-EMS-H	1
Emergency Stop for DiamaPro 10" Scarifier	DP-SCAR10-SAFS	1
SAM Bezel for DiamaPro 10" Scarifier	DP-SCAR10-SBZ	1

BRAKE SHOE ASSEMBLY (not pictured)

DESCRIPTION	PART #	QTY
Brake Shoe Assembly for DiamaPro 10" Scarifier	DP-SCAR10-BRK	1

WIRING DIAGRAM - GAS MODEL

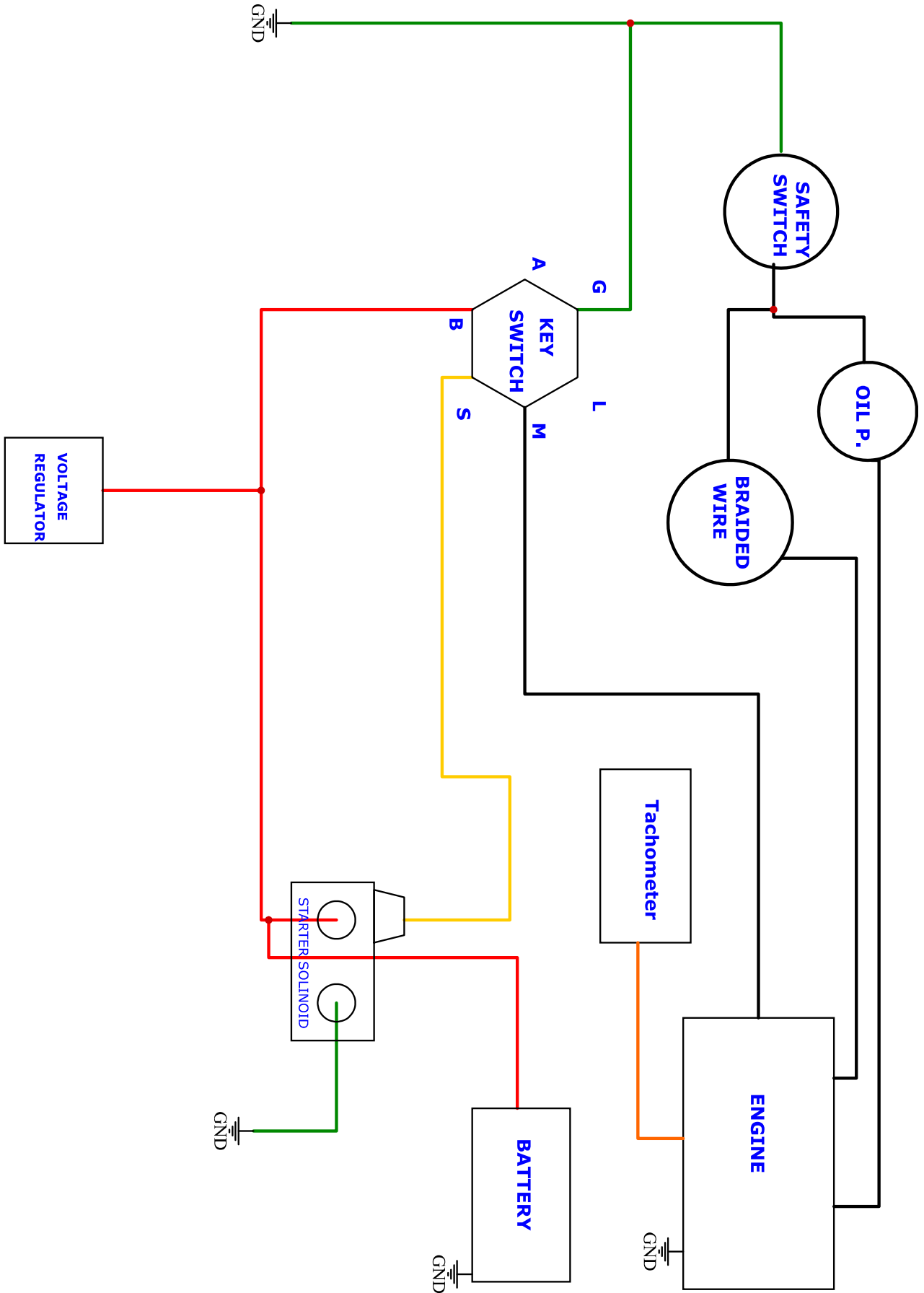

WIRING DIAGRAM - PROPANE MODEL

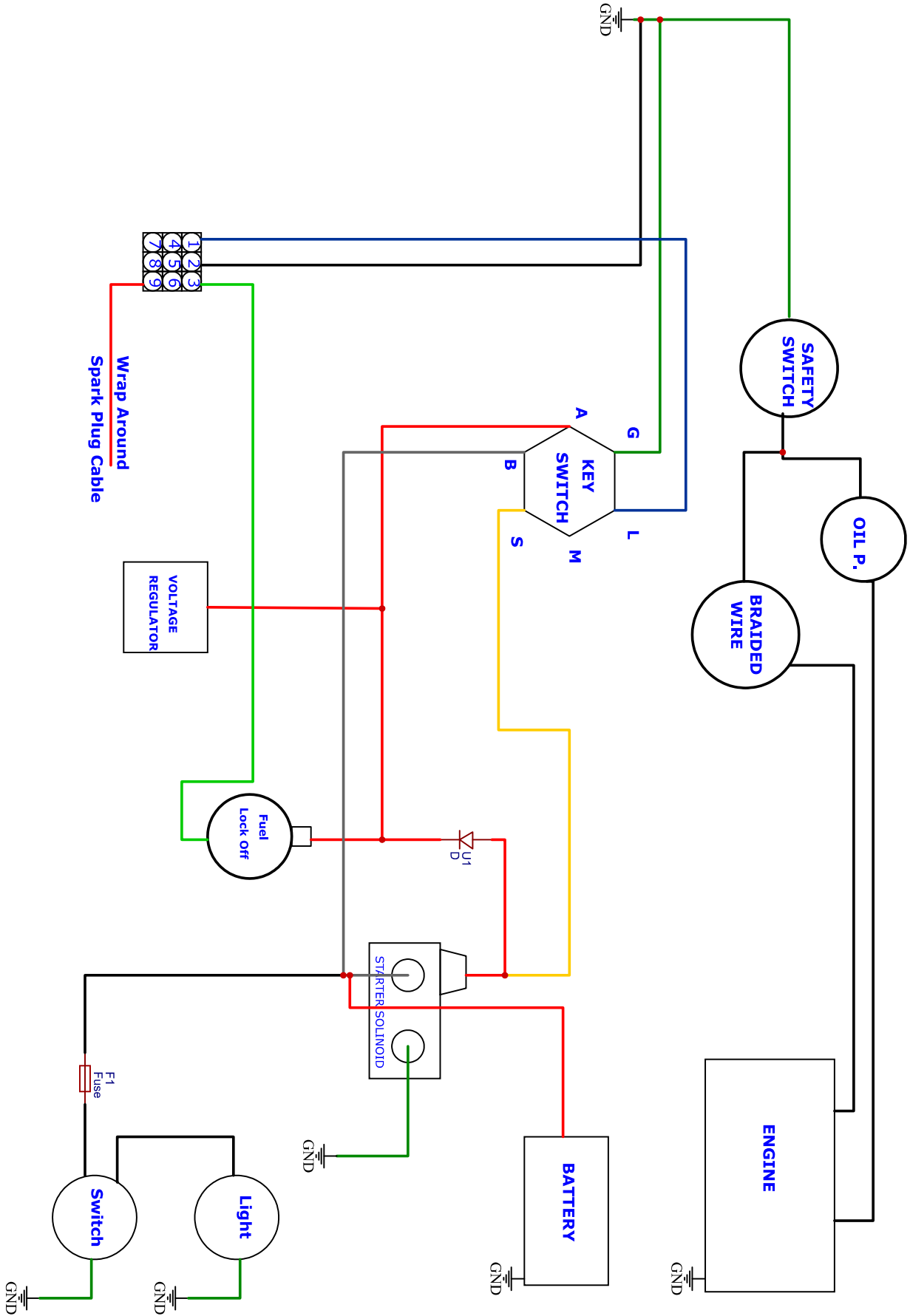



Diamapro[®]

SYSTEMS

Diamapro[®] Systems
3343 Peachtree Road NE
Suite 145 #24
Atlanta, GA 30326
470-977-2323