



Diamapro[®]
SYSTEMS

OWNER'S MANUAL

SCR-84

WALK-BEHIND FLOOR SCRAPER



OPERATION & MAINTENANCE MANUAL

SAVE THESE INSTRUCTIONS FOR FUTURE REFERENCE



WARRANTY REGISTRATION CARD

Form must be completed and submitted within 30 days from the date of purchase.

Customer Information

First and Last Name

Company Name

Address

City

State

Zip Code

Phone Number

Email

Machine Information

Machine Type

Machine Model

Serial #

Purchase Date (dd/mm/yy)

Diamapro® Systems
3343 Peachtree Road NE
Suite 145 #24
Atlanta, GA 30326

INTRODUCTION

This manual guarantees the safe and efficient use of the machine. This manual is part of the machine and has to always be kept near the machine and be accessible for the operating personnel at all times.

The operating personnel have to have carefully read and understood this manual before any work commences. Prerequisite for safe working is the compliance with all the safety and handling instructions in this manual. Furthermore, the local accident prevention regulations and the general safety conditions for the use of the machine are applicable. Illustrations in this manual are for the purpose of explanation and may differ from the actual design of the machine.

When passing the machine on to third parties this manual must be included. All of the instructions and technical specifications in this manual have been written in compliance with current technical norms and regulations together with our many years of knowledge and experience.

Disclaimer: DiamaPro® Systems and its affiliates take no responsibility for any damage, injury or death resulting from the incorrect or unsafe use of this product. Use of this product should be undertaken by competent persons only. It is the operator's responsibility to ensure that the following safety procedures are followed. If you are unsure, do not operate this product.

1. SAFETY

IT IS THE OPERATORS RESPONSIBILITY TO READ THIS MANUAL AND USE THE MACHINE IN A SAFE MANNER: Failure to follow written instructions and warnings symbols depicted in this instruction manual and on the machine may result in serious injury or death for the user and other persons. Read, understand and follow all the instructions, warnings, and general safe work practices, which are depicted on the machine and in the instruction manual at all times.



Mandatory Action



Warning/Caution



General Safe Condition



Prohibited Action

1.1. Electrical Safety



Always disconnect machine from power before servicing.

Maintenance, replacement or adjustment of parts can cause serious injury or death to the user or other persons, if the machine is connected to the power supply while servicing.



Keep the cable away from the blade to avoid damaging the cable.

DO NOT run over or damage the power cord, this can cause a dangerous electric shock.



The machine is constructed for use in dry environments only.

Danger of electric shock. Do not expose the machine to water or rain.



Connect to 120V AC power only.

Connecting the machine to an incorrect power supply can cause damage to the machine and injury to the user and persons in proximity.



Extension Cord– Only use machine with 12 gauge or larger and 50' or less length of cord.

Use of extension cords that are too small or too long can cause dangerous overloading of the cord and machine resulting in potential fire and electrical hazards.

Electrical cables and plugs must be kept in good condition and replaced by trained electrical technicians when damaged

. Whether it is due to normal wear or abuse electrical cables and plugs can wear out and expose operators and persons in proximity to danger of electrocution or burn. Inspect all electrical cables and plugs before use, worn or damaged electrical cables and plugs must be replaced by a trained electrical technician.



Never operate with a damaged cable or plugs.

Replacement of worn or damaged cables or plugs must be completed by a qualified person.



Improperly connecting the grounding wire can result in risk of electric shock.

Check with a qualified electrician if you are in doubt as to whether the outlet is properly grounded. Do not modify the plug on the machine. Never remove the grounding prong from the plug or extension cords. Do not use the tool if the cord or plug is damaged. If the plug will not fit the outlet, have a proper outlet installed by a qualified electrician.



Do not use machine when cable is damaged. Do not move the machine by dragging the cable. Utilization with a damaged cable can cause an electric shock.

1.2. Operator Warnings



The operator has to be instructed to the use of the machine before operating.

Failure to observe the information in this instruction manual before use, adjustment or maintenance could cause serious injury to persons or property.



Read all security statements. Be sure that data plate and warning labels are mounted / fixed to the machine.



Operator and persons in proximity must wear proper personal protective equipment including eye-protection, ear protection, closed toe shoes, N95 minimum dust mask and hearing protection. Removal of flooring materials and performing maintenance on machine can cause hazardous flying debris, airborne dust, hazardous debris on walking surfaces, and loud noises.



Keep arms, feet and clothes away from the operating machine parts.

Moving parts of the machine can cause serious injury or damage.



Operator must know what type of material is being removed.

Flooring can be composed of material that is harmful to be exposed to, especially in the form of air born dust. Some of these dangerous materials including asbestos and lead must not be removed by machine and must only be re-mediated by licensed professionals.

1.3. Usage



SPARE PARTS

Only use original spare parts and accessories specially made for this machine. DO NOT USE NON ORIGINAL EQUIPMENT MANUFACTURES PARTS FOR REPLACEMENT. Failure to use original parts can cause early failure or potentially dangerous failures or operating conditions. The manufacturer assume no liability for damages / injury caused by after-market parts.



When replacing spare parts or electrical components, the technical data specified by the manufacturer must be observed and original spare parts must be used. Do not use machine if connecting cables or components are not in good operating condition.



WORK SAFETY

The scraper SCR-84 is built according to the state of the art and the recognized safety-technical rules and must only be used for its intended purpose in safe working environment.



Improper use of the machine can cause injury / damage to the operator, property, bystanders, and the machine itself. When working with the machine the operator must pay attention to other persons in the work space. It is not recommended to use this machine around children due to the unavoidable hazard of an unprotected sharp blade at a low height. If the machine fails in any manner, it must be switched off immediately and disconnected by unplugging the power cord from the power supply then lock the cord end and tag the machine until repaired.



INTENDED USE

The scraper SCR-84 is intended exclusively for light duty removal of bonded floor coverings such as linoleum, rubber, carpets and vinyl coverings installed in dry areas on flat walking surfaces. Any other use is considered to be improper and the manufacturer is not liable for damage or injury caused by improper use.



Do not use non standard blades not approved by the manufacturer. Do not use machine on wet surfaces.

2. PRODUCT INFORMATION

2.1. Technical Description

A powerful stripper for small and medium-sized areas. Works on wooden or concrete surfaces and will remove virtually any substance adhering to the floor.

SPECIAL FEATURES:

- adjustable cutting angle
- adjustable handle
- machine runs very quiet with reduced vibration
- big wheels ensure easy mobility on job sites
- foldable handle for easy transport

2.2. Technical Data

POWER SUPPLY	110 V
DRIVE SYSTEM	MANUAL
MOTOR SIZE	1 HP
CUTTING ACTION	ORBITAL
WEIGHT	84LBS
DIMENSIONS (LxWxH)	22 X 13 X 43 IN



The vibration level may differ from the indicated value during use depending on the blade size and type of material being removed.

Do not use the machine continuously for more than 120 min.



Prolonged exposure to vibration can cause injury to hands and arms. Take frequent breaks, wear vibration reducing gloves, ensure machine is in good repair so vibration is kept to the lowest amount possible.

2.3. Standard Accessories

Machine is sold with 6mm hex wrench for installing blades.



The SCR-84 is delivered in transport position.

For instructions on setting to the working position, see Section 3.2: Adjusting Handle Height.



3. SETUP

3.1. Machine Description



3.2. Adjusting Handle Height



- The height of the handle can be adjusted in three positions.
- Remove the locking pin
 - Adjust handle to preferred position and re-install locking pin

FIG 3-A



3-A

3.3. Adjustment of Working Angle



A steep / aggressive angle works best for removing glue and for thin materials. A low / less aggressive angle is best for most removal situations. The type of sub floor can also change what working angle is best. Typically a high aggressive angle will not work well on a wood sub floor, but will work fine on concrete.

FIG 3-B

- Loosen the clamping lever on the wheel assembly
- Lift on the handle to raise the back the of the machine, the wheel assembly will slide keeping the wheels in contact with the floor
- Tighten the clamping lever again to hold the machine in the desired position.



Regardless of the working angle, the handle bar should always be adjusted to the user's belt height.

FIG 3-C



3.4. Choice of Blade

- bevel up for concrete.
- bevel down for wood or soft sub-floors.
- Narrow blades reduce the amount of effort required to push the machine.



3.5. Change Blade



Dull blades reduce the performance of the machine. Sharpen or replace the blades as needed.



CAUTION! Sharp blades are dangerous. Wear protective gloves when changing or sharpening blades. Use the supplied extended wrench to keep hand safely away from the edge of the blade when installing on machine.

FIG 3-I

1. Place a block under the front of the machine

FIG 3-J

2. Loosen the two bolts with the extended bolt wrench and replace the blade.



It is not necessary to remove the bolts



Be sure that the blade is far enough under the blade-holder, to insure a secure hold.
USE ONLY ORIGINAL BLADES



3.6. Sharpening the Blade



Always wear gloves and safety glasses.



It is not necessary to remove the bolts.

1. Sharpen the blade mounted to the machine. Using hand grinder, block up front of machine so blade is off the floor. Only grind on the original beveled edge maintaining factory angle. Machine works best with a single-sided bevel. Sharpen the blade with 5" or smaller diameter disk with 120 or finer grit.



Be careful not to catch disk on edge or corner of blade.

FIG 3-K Blade sharpened "bevel down"

FIG 3-L Blade sharpened "bevel up"

FIG 3-M Sharpening with a fine-toothed file

2. Blade can also be effectively sharpened on a bench grinder or while secured in a vice. Follow all the same instructions listed above.



4. OPERATION

4.1. Start the Machine

1. After blade is installed plug in 12 gauge or heavier cord to 15amp minimum 120v power source and connect to the machine.
2. Press the green power button on the handle and the machine will start.

4.2. Removal of Floor Coverings



Keep blades sharp! Sharpening blades frequently will significantly increase productivity and ease of use. Keep your work area clean and clear of debris. Always wear eye and ear protection when working with the machine.



Vinyl, Rubber, PVC, Direct Glued Carpet

Pre-score the flooring by cutting it into strips approximately the width of the blade. Pre-scoring carpet / sheet goods allows for easy handling of the removed material and reduces the amount of effort required to break the adhesive bond.

FIG 4-B



For materials with a strong bond use a low blade angle. A second pass with a high blade angle can be used to remove residual adhesive.

If working over a wood sub-floor, a high blade angle will cause the blade to dig in. A very sharp blade at a low angle can be used to remove adhesive or a secondary process such as sanding with course paper may be required.

For soft coverings that are attached with a strong bond self scoring blades with vertical cutting wings can be used.



4-C

5. TROUBLESHOOTING

FAULT	REMEDY
Machine will not start	<ul style="list-style-type: none"> Ensure outlet has power, check for damage in cord,
Noise from motor	<ul style="list-style-type: none"> Look for damage to fan cover on top of motor
Rattling noise from machine	<ul style="list-style-type: none"> Check for proper torque on wheel axles and legs, parts should be easy to move but not loose. Pull bottom cover and check for broken isolators or bad cutting head bearing.
Machine is hard to push	<ul style="list-style-type: none"> Sharpen the blade, set blade to low angle, switch to smaller blade
Frequent trip of circuit breaker	<ul style="list-style-type: none"> Try to find a different circuit Replace extension cord, use shorter and or heavier gauge extension cord.

6. MAINTENANCE / CARE / REPAIR



Before startup:

Check the guards, electrical components and cords for damage
 Check wheel assembly, bottom cover, and cutting head are secure and in good working order
 Check the blade - Blades can become dull very quickly and cause significant decrease in performance



When putting the machine away:

Unplug extension cable from machine and power source
 Remove the blade from the machine and put in a safe place



Prolonged exposure to corrosive environments, high humidity, and direct sunlight will cause premature wear and failure to metal, plastic and rubber components. When not in use, store the machine under cover in a clean dry place.



Perform maintenance, repair, or cleaning on the machine with the blade removed and no power connected.



NEVER use a pressure washer or garden hose to clean the machine. If difficult cleaning is required the use of conventional degreaser, cleaners, adhesive removers and a cloth is the recommended method. Take care to not remove or deface any safety, warning, or instruction labels.



DO NOT modify, remove, or render inoperable any guards or safety elements of the machine.



If the plug of the machine needs to be replaced the manufacturer recommends not to use assembly style plugs.

The machine is designed to have a molded plug and cable to ensure long life and maximum safety from electrical hazards. Only use original replacement parts and have them installed by a trained electrical professional



Dispose of the machine in accordance with all local laws and ordinances..



7. REPLACEMENT PARTS

RECOMMENDED REPLACEMENT PARTS

PART NUMBER	DESCRIPTION	QTY.
DP-SCR-10251	ON/OFF SWITCH	1
DP-SCR-10426	MOLDED PIGTAIL	1
DP-SCR-10470	CABLE FROM SWITCH TO MOTOR	1
DP-SCR-10427	STRAIN RELIEF	1
DP-SCR-10172	HANDLE PIN	1
DP-SCR-10449	FLAT RUBBER GRIP	1
DP-SCR-10448	ROUND RUBBER GRIP	2
DP-SCR-10146	CUTTING HEAD FLANGE BEARING	1
DP-SCR-10469	ISOLATOR	4
DP-SCR-10477	NYLON WASHER	2
DP-SCR-10478	NYLON WASHER	2

8. PARTS BREAKDOWN & PARTS LIST

ELECTRICAL COMPONENTS

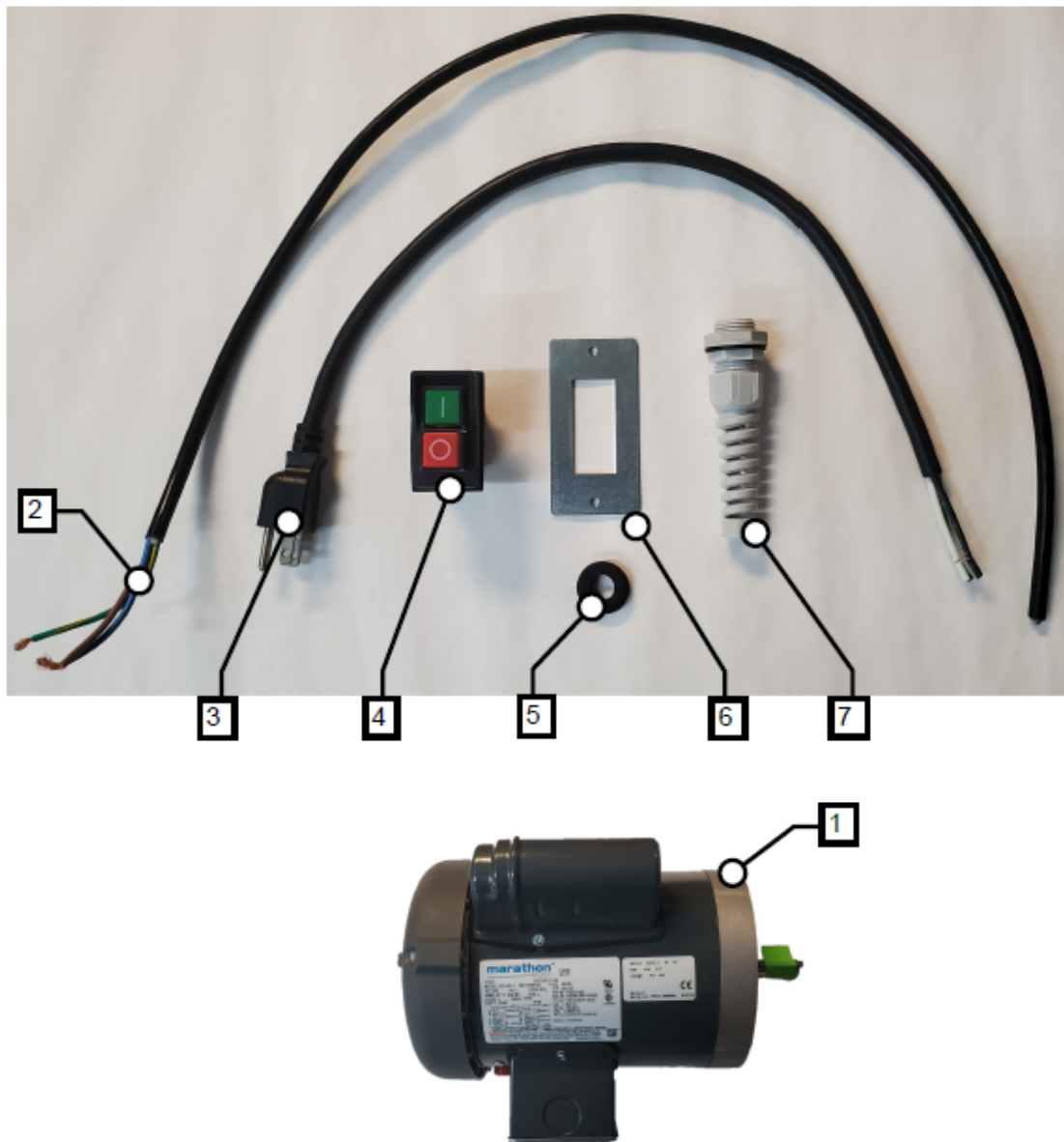

ITEM #	PART NUMBER	DESCRIPTION	QTY.
1	DP-SCR-10467	ELECTRIC MOTOR	1
2	DP-SCR-10470	CABLE FROM SWITCH TO MOTOR	1
3	DP-SCR-10426	MOLDED PIGTAIL	2
4	DP-SCR-10251	ON/OFF SWITCH	1
5	DP-SCR-10471	RUBBER GROMMET	1
6	DP-SCR-10192	SWITCH PLATE	1
7	DP-SCR-10427	STRAIN RELIEF	1

8. PARTS BREAKDOWN & PARTS LIST

CUTTING HEAD & WHEELS COMPONENT



ITEM #	PART NUMBER	DESCRIPTION	QTY.
1	DP-SCR-10146	CUTTING HEAD FLANGE BEARING	1
2	DP-SCR-10475	ECCENTRIC	1
3	DP-SCR-10469	ISOLATOR	1
4	DP-SCR-10200	AXEL BOLT	1
5	DP-SCR-10477	NYLON WASHER	1
6	DP-SCR-10478	NYLON WASHER	1
7	DP-SCR-10205	NYLON INSERT LOCK NUT	1
8	DP-SCR-10206	WHEEL	1

8. PARTS BREAKDOWN & PARTS LIST

CUTTING HEAD AND DRIVE COMPONENTS



ITEM #	PART NUMBER	DESCRIPTION	QTY.
1	DP-SCR-10472	WRENCH HOLDER	1
2	DP-SCR-10306	HEX WRENCH (FOR BLADE CLAMP)	1
3	DP-SCR-10473	TUBE CAP	1
4	DP-SCR-10449	FLAT RUBBER GRIP	1
5	DP-SCR-10448	ROUND RUBBER GRIP	1
6	DP-SCR-10172	HANDLE PIN	1
7	DP-SCR-10474	OPERATION INSTRUCTIONS PLATE	1

8. PARTS BREAKDOWN & PARTS LIST

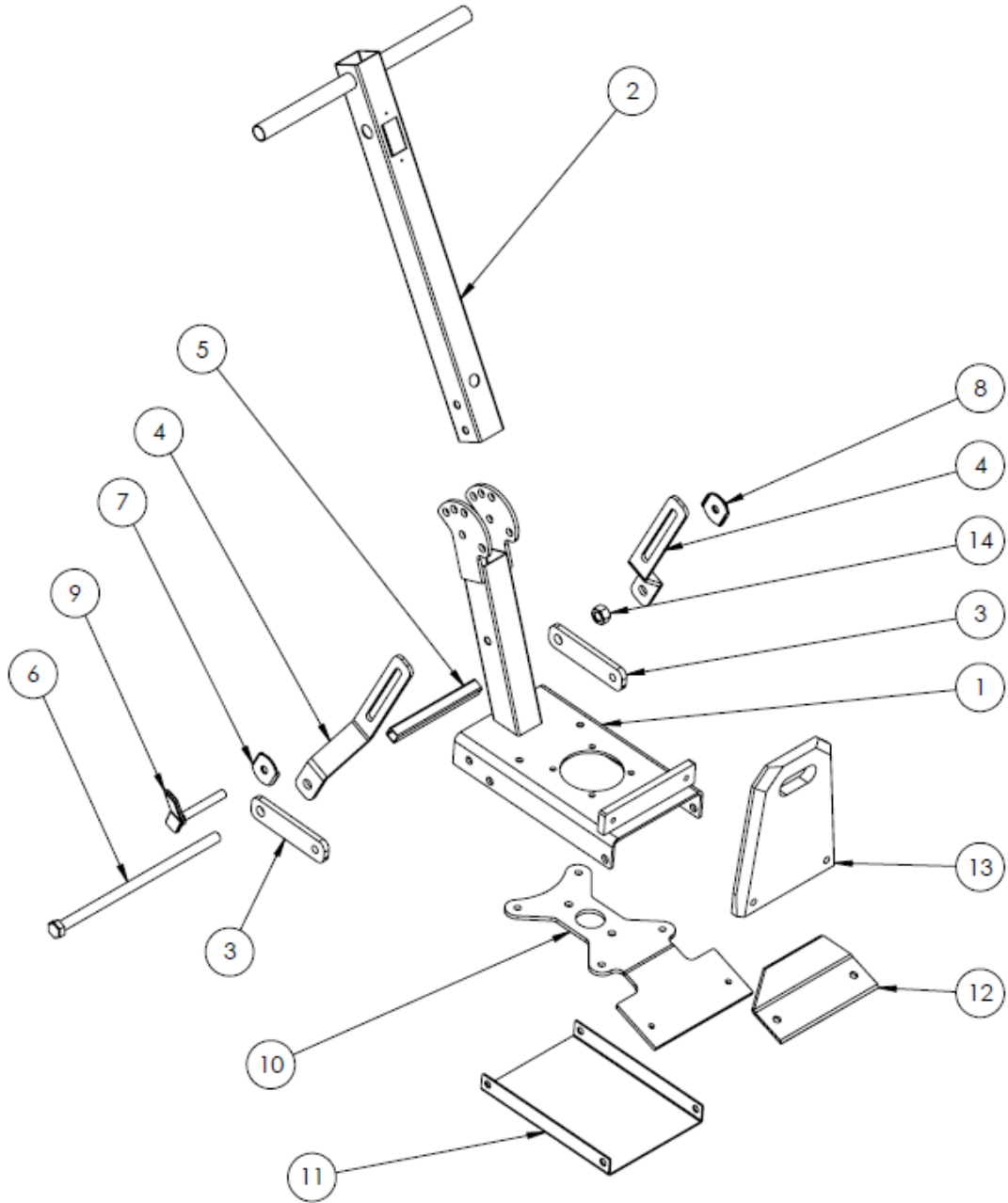

8. PARTS BREAKDOWN & PARTS LIST

FRAME KIT PARTS

ITEM #	PART NUMBER	DESCRIPTION	QTY.
1	DP-SCR-10198	FRAME	1
2	DP-SCR-10199	HANDLE	1
3	DP-SCR-10195	WHEEL LINKAGE	2
4	DP-SCR-10191	STRAP	2
5	DP-SCR-10196	WHEEL SPACER	1
6	DP-SCR-10200	AXEL BOLT	1
7	DP-SCR-10201	PLAIN STRAP WASHER	1
8	DP-SCR-10202	STRAP WASHER WITH NUT	1
9	DP-SCR-10184	HANDLE BOLT	1
10	DP-SCR-10187	CUTTING HEAD	1
11	DP-SCR-10185	BOTTOM COVER	1
12	DP-SCR-10183	BLADE CLAMP	1
13	DP-SCR-10197	590 CUT WEIGHT	1
14	DP-SCR-10205	NYLON INSERT LOCK NUT	1

ANCILLARY PARTS

ITEM #	PART NUMBER	DESCRIPTION	QTY.
NP	DP-SCR-10206	WHEEL	2
NP	DP-SCR-10146	CUTTING HEAD FLANGE BEARING	1



Diamapro® Systems
3343 Peachtree Road NE
Suite 145 #24
Atlanta, GA 30326
470-977-2323